

# skye

## 5 & 7

*Operating & Installation Instructions*



# CONTENTS

<b>QUICK GUIDE</b>	<b>4</b>
<b>OPERATING INSTRUCTIONS</b>	<b>5</b>
FUEL	5
WOOD LOGS	5
MULTI GRATE	5
RIDDLING	6
LIGHTING	6
CONTROLLING THE FIRE	6
REFUELLING	7
ASH CLEARANCE	7
OPERATING TOOL HOLDER	7
REDUCED BURNING	7
MAINTENANCE	8
THROAT PLATE AND FLUEWAY CLEANING	8
CHIMNEY SWEEPING	8
TROUBLE SHOOTING	9
CO ALARM	10
IF YOU NEED FURTHER HELP	10
<b>INSTALLATION INSTRUCTIONS</b>	<b>11</b>
UNPACKING THE STOVE	11
HEALTH AND SAFETY PRECAUTIONS	11
CO ALARMS	11
SPECIFICATION	11
CHIMNEY	12
HEARTH AND FIRE SURROUND	12
CONNECTIONS TO FLUES	12
SOOT DOORS	13
PRE LIGHTING CHECK	14
COMMISSIONING	14
FITTING THE REAR HEAT SHIELD	14
CAA AND SMOKE CONTROL	14
<b>SKYE 5 DIMENSIONS</b>	<b>16</b>
<b>SKYE 7 DIMENSIONS</b>	<b>17</b>
<b>PARTS LIST</b>	<b>18</b>
SKYE 5 STORE STAND PARTS LIST	18
SKYE 5 LOW PARTS LIST	19
SKYE 7 STORE STAND PARTS LIST	20
SKYE 7 LOW PARTS LIST	21
<b>CERTIFICATION</b>	<b>22</b>

# QUICK GUIDE

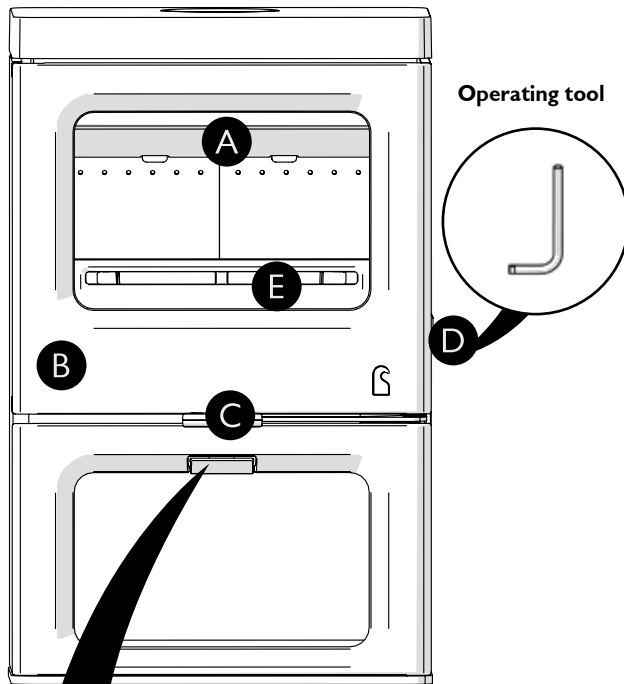

- A Throat plate**  
Improves efficiency of stove by slowing down flue gases
- B Door**  
Keep closed when stove is in use
- C Door handle**  
Pull out to open
- D Riddler knob**  
Use operating tool to riddle
- E Fuel retainer**  
Ensure fuel does not protrude beyond retainer

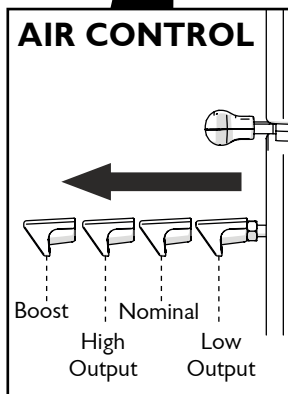

## MAINTENANCE AND CLEANING

### GLASS

Wipe with damp, lint free cloth. Any stubborn deposits on the glass may be removed with a proprietary stove glass cleaner or ceramic hob cleaner.

### THROAT PLATE & UPPER BAFFLE

Take down once a month and clean. Sweep sooty deposits into fire

### CHIMNEY

Have chimney swept twice a year. Chimney can be swept through stove.

### SERVICING

Stove should be serviced by a professional at least once a year.

## LIGHTING AND CONTROLLING THE FIRE

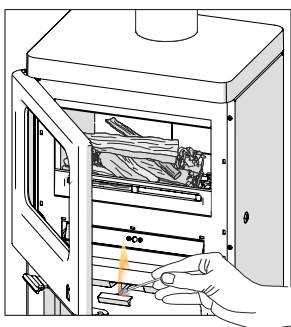

**Add kindling and paper or firelighters.** Keep air control fully out and door cracked open.

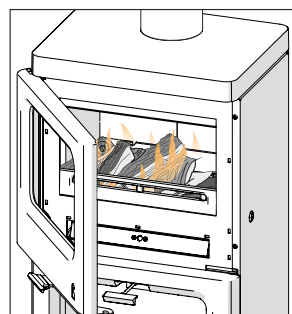

**Once kindling is alight, add smaller logs.** Keep air control fully out and close door.

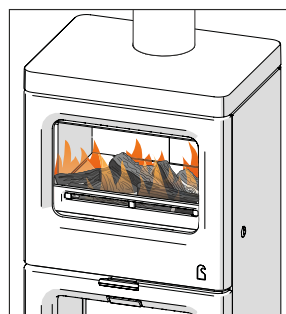

**Add larger logs once fire is established.** Air control can be reduced to minimum.

### Suitable fuels for your Charnwood:

Wood logs  
Smokeless Fuel

### Unsuitable fuels:

Petroleum coke  
Liquid fuel  
Household waste  
Coal singles  
Small nuts or coal dust  
Wet or unseasoned wood



Congratulations on becoming the owner of a Charnwood Skye Stove. Your stove has been approved in smoke control areas to burn wood logs if it is used in accordance with these instructions. It is very important that you read and understand these instructions before using the stove.

Before lighting the stove check with the installer that the work and checks described in the Installation Instructions have been carried out correctly and that the chimney has been swept, is sound and free from any obstructions. The stove is not suitable for use in a shared flue system.

Remember that the stove will be hot and that it is made from hard materials – ensure that you have good balance before operating the fire. Always use the provided operating tool and gloves.

Do not use an aerosol spray on or near the stove when it is alight. There is a risk of explosion or flash ignition of the spray.

When using the stove in situations where children, aged and/or infirm persons are present a fireguard must be used to prevent accidental contact with the stove. The fireguard should be manufactured in accordance with BS 8423:2002.

The stove is suitable for intermittent operation.

## FUEL

Please pay careful attention to the special points made with each type of fuel as they will help you to get the best from your stove. It must be remembered that only authorised fuels and wood logs may be burnt in smoke control areas on this stove. If you are not sure whether you are in a smoke control area, please check with your Local Authority.

At first you may find it helpful to try several fuels to find the most suitable. If you are unable to obtain the fuel you want, ask your supplier, or an approved fuel distributor, to suggest an alternative.

### Authorised Mineral Fuels

Authorised mineral fuels may be burned in smoke control areas on this appliance. Your local fuel supplier or stove shop will be able to advise you which fuels are available locally. A list of authorised fuels can be found at:

<https://smokecontrol.defra.gov.uk/fuels.php>

Take care to only burn good quality fuels in order to obtain the greatest efficiency and to maintain the life of the appliance.

## WOOD LOGS

Only dry well seasoned wood should be burnt on this appliance as burning wet unseasoned wood will give rise to heavy tar deposits in the stove, on the glass and within the chimney. For the same reason hard woods (such as Ash, Beech and Oak) are better than soft woods (such as Pine and Spruce). Burning wet unseasoned wood will also result in considerably reduced outputs. The wood should be cut and split and then left to season in a well ventilated dry place for at least one year but preferably two years before use. Approximate suitable log sizes are:

**Skye 5**, 290mm(7in) long and 75mm (3in) diameter

**Skye 7**, 400mm (16in) long and 75mm (3in) diameter

Log moisture content of less than 20% is recommended.

## PETROLEUM COKE IS NOT SUITABLE FOR USE ON THIS APPLIANCE. ITS USE WILL INVALIDATE THE GUARANTEE.

This stove is not designed to burn household waste.

HETAS Ltd Appliance Approval only covers the use of Wood Logs and Smokeless Fuels on this appliance.

## MULTI GRATE

Your Charnwood Skye is fitted with a multi grate to enable wood or smokeless fuel to be burned and ash to be cleared. The grate has two positions:

- 1) In the solid fuel position the grate bars are vertical with gaps in between allowing the primary combustion air to come up through the grate and through the fuel bed.
- 2) In the wood position the grate bars are horizontal, allowing the combustion air to come round the sides of the grate and over the top of it. When in the closed position ash is able to build up on the grate as is necessary for effective wood burning.

Movement of the grate from one position to the other is effected using the operation tool supplied as shown in Fig.1.

The grate is put into the solid fuel position by turning the operation tool anticlockwise and pulling out the fuel selection slider shown in Fig.1. The grate is put into the wood position by turning the operation tool clockwise. To riddle the appliance the tool should be moved between the clockwise and anticlockwise positions several times. When burning wood the ash should be allowed to build up and riddling should only be carried out once or twice a week.

# OPERATING INSTRUCTIONS



**Fig. 1 Operating the multi grate**

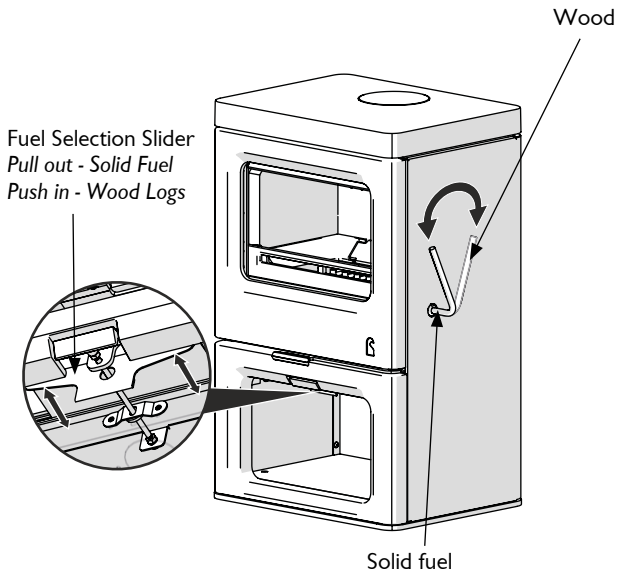

## RIDDLING

When burning wood, ash should be allowed to build up and only riddled when the ash begins to cover the rear fireplate. The fire should be riddled with the door shut (see Fig.2). Place the operating tool onto the riddling lever and rotate between the open and closed positions several times. Too much riddling can result in emptying unburnt fuel into the ashpan and should therefore be avoided. After riddling, the grate should be put back into the closed position for burning wood.

**Fig. 2 Riddling tool**

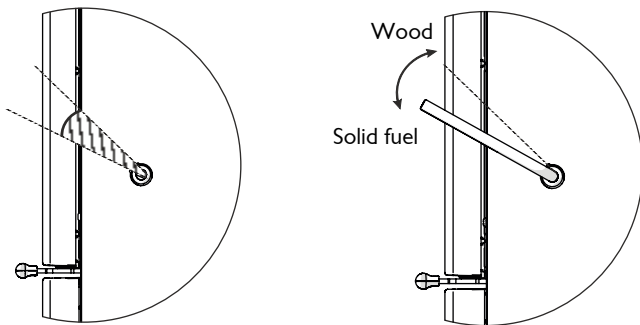

## LIGHTING

On initial lighting, the stove may smoke and give off an odour as the silicon paint with which the firebox is painted reacts to the heat. This is normal and will cease after a short time, but meanwhile the room should be kept well ventilated.

At first only light a small fire and burn it slowly for two hours to allow

any residual moisture in the chimney to evaporate.

Light the stove using dry kindling wood and paper or fire lighters. Put the paper, or fire lighters, and kindling in the firebox and cover with a few small dry logs. Open the air control fully (see Fig. 3). Light the paper or fire lighters. The door may be left cracked open for a few minutes to assist the combustion and heat up the firebox more quickly. When the kindling wood is well alight add a few more small logs, close the door but leave the air control fully open. When the flames are established around these logs, load the stove with the required fuel load. Maintain the air control at maximum at this stage. Once the fire is up to temperature the airwash system will begin to work, so allow the fire to become hot before adjusting the air control to the required setting. During the lighting period, do not leave the stove unattended. Do not leave the door open except as directed above to avoid excessive smoke.

When relighting the stove, leave the ash on the base if burning wood, unless it is becoming too deep, in which case some of it may be removed.

## CONTROLLING THE FIRE

The rate of burning and hence the output is controlled by the air control (see Fig.3)

**Fig. 3 Stove controls**

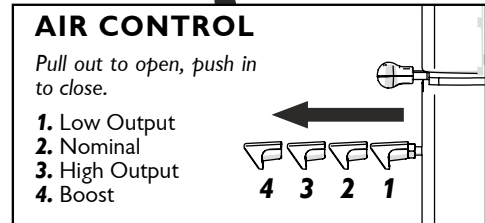
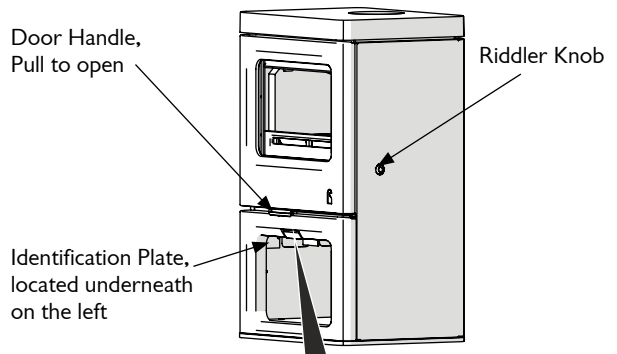

Open the air control fully (boost position) when lighting or when rapid burning is required. It should not be left fully open for long periods as this can cause over-firing or excessive smoke production. For high output move the air control to the 'click position' or for low



burning to the fully closed position.

When the fire is burning normally the air control gives enough airwash to keep the glass clean. However, it will not always be possible to keep the glass clean with the air control fully closed. For correct firing we recommend the use of a stove pipe thermometer which may be purchased from your supplier or from Charnwood.

The Charnwood Skye 5 is fitted with an air control stop for use in a smoke control area. This stops the stove from burning too slowly.

## REFUELLING

Keep the firebox well filled but do not allow fuel to spill over the top of the fuel retainer.

Logs should be evenly distributed, filling the firebed to give the most pleasing flame pattern. The air control must be fully opened after refuelling until the flames are established above the fire. It is best to refuel on to a hot bed of embers. If at this point the fire starts to die, the door must be cracked open until the fire is revived. If the fire has started to die down before refuelling, then more kindling wood must be added, the air control opened fully and the door cracked open to re-establish the firebed before adding larger logs (see suitable log sizes in Fuel section). This will avoid excessive smoke emission.

Care should be taken, especially when burning wood, that fuel does not project over the fuel retainer or damage to the glass may be caused when the door is closed. It can also cause the glass to blacken up. Maximum filling height is such that logs cannot fall from the fire when the door is opened.

In smoke controlled areas do not fill the stove above the level of the air holes in the back bricks, as overloading can cause excess smoke.

Do not operate with the door left open except as directed by the instructions as this can cause excessive smoke.

## ASH CLEARANCE

For optimum wood burning, it is important to leave a layer of ash around 1cm thick on the base of the stove. Before removing ash ensure that it has cooled down,

The ashpan is handled using the operation tool and gloves provided. Ensure that the tool is fully engaged before lifting (See Fig.4). When carrying the ashpan, it should be kept horizontal and supported by the carrying handle to prevent it falling off the tool. Please avoid emptying hot ash into plastic liners or bins.

The Ashpan should be emptied regularly before it becomes too full. Never allow the ash to accumulate in the ashpan so that it comes in contact with the underside of the grate as this will seriously damage the grate bars.

To make ash removal easier there are ash carriers available. These may be purchased from your supplier or, in case of difficulty, from Charnwood.

**Fig. 4 Ashpan**

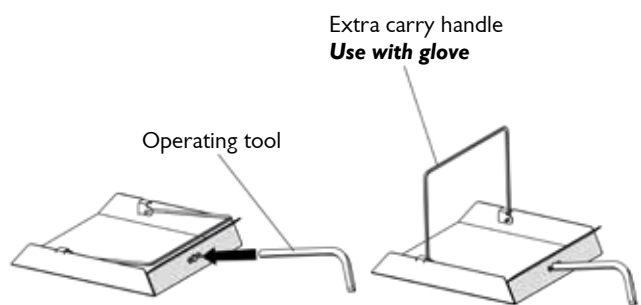

## OPERATING TOOL HOLDER

When not in use the operating tool can be stored inside the store stand or on the shelf underneath the stove. (See fig. 5.)

**Fig. 5 Operating tool storage**

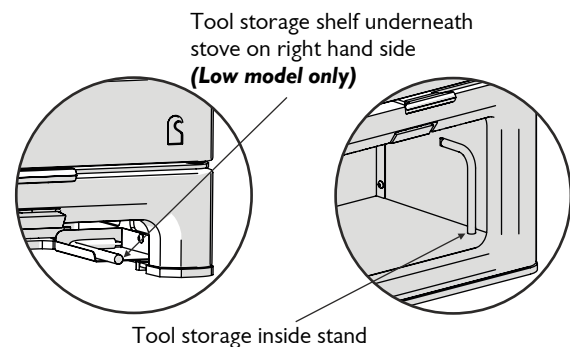

## REDUCED BURNING

For reduced burning the fire door must be closed.

When burning wood in areas that are not smoke controlled, load some large logs on the fire and allow to burn for half an hour before closing the air control (this will help to reduce tar deposits in the chimney). Some experimentation may be necessary to find the setting most suitable for the type of fuel being used and the draw on the chimney.



## MAINTENANCE

### Cleaning

The stove is finished with a high temperature paint which will withstand the temperatures encountered in normal use. This may be cleaned with a damp lint-free cloth when the stove is cold. Should re-painting become necessary, high temperature paints are available from your supplier or from stove shops.

### Cleaning the Glass

Most deposits on the glass may be burnt off simply by running the fire at a fast rate for a few minutes. If it becomes necessary to clean the glass then open the door and allow it to cool. Clean the glass using a damp cloth and then wiping over with a dry cloth. Any stubborn deposits on the glass may be removed with a proprietary stove glass cleaner or ceramic hob cleaner. Do not use abrasive cleaners or pads as these can scratch the surface which will weaken the glass and cause premature failure

### When Not in Use

If the fire is going to be out of use for a long period (for instance in the summer) then to prevent condensation, and hence corrosion, the air control should be left fully open and the fire door left ajar. It is also advisable to sweep the chimney and clean out the fire. Spraying the inside of the door and firebox with a light oil, such as WD40, will also help to keep all internal parts working well. After long periods where the fire has been out of use, the chimney and appliance flueways should be cleaned before lighting.

### Door Seals

For the fire to operate correctly it is important that the door seals are in good condition. Check that they do not become worn or frayed and replace them when necessary.

### Servicing

It is recommended that the fire is serviced once a year to keep it in first class working order. After cleaning out the firebox thoroughly, check that all internal parts are in good working order, replacing any parts that are beginning to show signs of wear. Check that the door seals are in good condition and that the door seals correctly. A servicing guide is available on request. Repairs or modifications may only be carried out by the Manufacturer or their approved agents. Use only genuine Charnwood replacement parts.

## THROAT PLATE AND FLUEWAY CLEANING

It is important that the throat plate and all the stove flueways are kept clean in order to prevent potentially dangerous fume emission. They should be cleaned at least monthly, and more frequently if necessary. It is necessary to let the fire out to carry out these operations.

To remove the throat plate, first remove the fuel retainer (item 'e' page 4) and one side plate to allow enough room so that the throat plate clears the sides of the fire box when removed.

Slide the throat plate forwards so that it clears the back brick, then slide it either right or left so that the opposite side clears the top of the remaining side brick and can be gently lowered. Any sooty deposits should then be swept from the throat plate and into the fire.

To return the throat plate to its correct position- At an angle, insert the throat plate so that it sits on top of either the right or left side brick. Raise the opposite side and slide so that the throat plate is central and supported by the side bricks. Slide back so that the throat plate rests neatly on the top of the back bricks. Refit the remaining side plate.

The upper throat plate (Skye 7 only) is positioned on top of the air wash tubes and is located with studs into the two holes on the bracket attached to the air wash manifold. The upper throat plate will not be required if the rear flue connection is used.

**Fig. 6. Throat Plate Location**

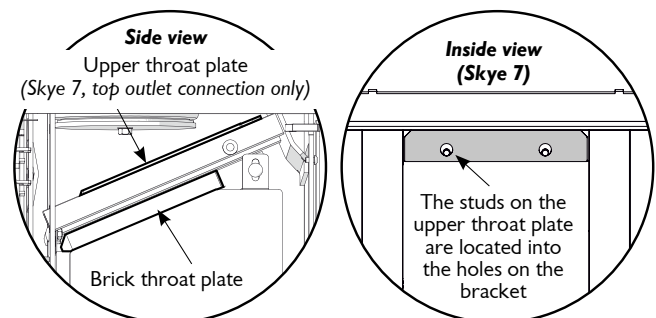

## CHIMNEY SWEEPING

Where the chimney previously served an open fire, it is possible that the higher flue gas temperature from a stove may loosen soot deposits with the consequent risk of flue blockage. It is therefore recommended that the chimney be swept a second time within a month of regular use after installation.

The chimney should be swept at least twice a year. Where the top outlet or vertical rear flue connector is used it will generally be





possible to sweep the chimney through the appliance.

First remove the fuel retainer, throat plate and upper baffle (Skye 7 only). Then sweep the chimney ensuring that soot is removed from all horizontal surfaces after sweeping.

In situations where it is not possible to sweep through the appliance the installer will have provided alternative means, such as a soot door. After sweeping the chimney the appliance flue outlet and the flue pipe connecting the stove to the chimney must be cleaned with a flue brush.

After clearing any soot from within the stove, replace upper baffle (Skye 7), the throat plate (see Fig. 5) and the fuel retainer.

Different types of sweep's brushes are available to suit different flueways. For prefabricated insulated chimneys the manufacturers instructions with regard to sweeping should be consulted.

## TROUBLE SHOOTING

### Fire Will Not Burn

Check that:

- the air inlet is not obstructed in any way,
- chimneys and flueways are clear,
- a suitable fuel is being used,
- there is an adequate air supply into the room,
- an extractor fan is not fitted in the same room as the stove.
- there is sufficient draw in the chimney. Once the chimney is warm a draught reading of at least 1.25 mm (0.05 in.) water gauge (12Pa) should be obtained.

### Blackening of Door Glass

Differences in chimney draughts mean that the best settings of the air controls will vary for different installations. A certain amount of experimentation may be required, however the following points should be noted and with a little care should enable the glass to be kept clean in most situations:

- Wet or unseasoned wood, or logs overhanging the front fence will cause the glass to blacken.
- The airwash relies on a supply of heated air to keep the glass clean, therefore, when lighting the stove allow the firebed to become well established before closing the air control. This may also be necessary when re-fuelling the stove.

c) When re-fuelling keep the fuel as far back from the front fence as possible, do not try to fit too much fuel into the firebox.

d) Do not completely close the air control.

It is always more difficult to keep the glass clean when running the stove very slowly for long periods.

If blackening of the glass still occurs check that all flue connections and the blanking plate are well sealed. It is also important that the chimney draw is sufficient and that it is not affected by down-draught. When the chimney is warm a draught reading of at least 1.25 mm (0.05 in.) water gauge (12Pa) should be obtained. Some blackening of the glass may occur below the level of the fuel retainer. This will not obscure the view of the fire or affect its performance.

### Fume Emission

#### Warning Note:

Properly installed and operated this appliance will not emit fumes. Occasional fumes from de-ashing and re-fuelling may occur. Persistent fume emission is potentially dangerous and must not be tolerated. If fume emission does persist, then the following immediate actions should be taken:

- Open doors and windows to ventilate the room and then leave the premises.
- Let the fire out and safely dispose of the fuel from the appliance.
- Check for flue or chimney blockage, and clean if required.
- Do not attempt to re-light the fire until cause of fuming has been identified, if necessary seek professional advice.

The most common cause of fume emission is flueway or chimney blockage. For your own safety these must be kept clean.

Fire blazing out of control

Check that:

- The door is tightly closed.
- The air control slider is fully closed.
- A suitable fuel is being used.
- Door seals and airwash slide are intact.

### Chimney Fires

If the chimney is thoroughly and regularly swept, chimney fires should not occur. However, if a chimney fire does occur close the air control, and tightly close the door of the appliance. This should cause the chimney fire to go out in which case the controls should be kept



closed until the stove has gone out. The chimney and flueways should then be cleaned. If the chimney fire does not go out when the above action is taken then the fire brigade should be called immediately. After a chimney fire the chimney should be carefully examined for any damage. Expert advice should be sought if necessary.

## **CO ALARM**

Your installer should have fitted a CO alarm in the same room as the appliance. If the alarm sounds unexpectedly, follow the instructions given under “Warning Note” above.

## **IF YOU NEED FURTHER HELP**

If you need further help with your Charnwood then your Installer will be able to provide the answers to most questions. Your Local Charnwood Premier Dealer has a great deal of experience and will also be able to provide helpful advice. Further help is available from the Charnwood Customer Services department who will be pleased to give advice, if necessary.

# INSTALLATION INSTRUCTIONS



## UNPACKING THE STOVE

The stove arrives bolted and strapped to its pallet. There must be adequate facilities for unloading and manoeuvring into position. The wrapping is first removed, then the stove released from the pallet by removing 4 pallet bolts using a 10mm spanner. The pallet brackets can now be removed from the stove by tilting it and using a 13mm spanner to remove the bolts. The pallet is intended to be cut up and used for kindling fuel.

## HEALTH AND SAFETY PRECAUTIONS

Please take care when installing the stove that the requirements of the Health and Safety at Work Act 1974 are met.

Some types of fire cement are caustic and should not be allowed to come into contact with the skin. In case of contact wash with plenty of water.

If there is a possibility of disturbing any asbestos in the course of installation then please use appropriate protective equipment.

If room air is used for combustion, then an extractor fan There should not be an extractor fan fitted in the same room as the stove as this can cause the appliance to emit fumes into the room.

There must be an adequate air supply into the room in which the appliance is installed to provide combustion air. The combustion air supply must be via a permanently open vent. The requirement for minimum free area is partly dependent on the design air permeability of the house. In older properties the air permeability will be above  $5.0\text{m}^3/(\text{h}\cdot\text{m}^2)$ , but in some modern properties it may be less. The vent must be positioned such that it is not liable to blockage. Minimum areas are given in the following table:

AIR PERMEABILITY $\text{m}^3/(\text{h}\cdot\text{m}^2)$	MINIMUM VENT AREA $\text{cm}^2(\text{in}^2)$	
	Skye 5	Skye 7
>5.0	No requirement	11 (1.76)
<5.0	27.5 (4.3)	38.5 (6.0)

A fixed ducted air supply may be used as an alternative to the traditional method of using a permanent open vent into a room to supply air for combustion.

External air supply kits are available please contact Charnwood for more information.

This stove is capable of intermittent operation, and is not suitable for use in a shared flue system.

In addition to these instructions the requirements of BS.8303 and BSEN 15287-1:2007 must be fulfilled. Local Authority Bylaws and Building Regulations, including those referring to national and European Standards, regarding the installation of Solid Fuel burning appliances, flues and chimneys must also be observed.

## CO ALARMS

Building regulations require that whenever a new or replacement fixed solid fuel or wood/biomass appliance is installed in a dwelling a carbon monoxide alarm must be fitted in the same room as the appliance. Further guidance on the installation of the carbon monoxide alarm is available in BS EN 50292:2002 and from the alarm manufacturer's instructions. Provision of an alarm must not be considered a substitute for either installing the appliance correctly or ensuring regular servicing and maintenance of the appliance and chimney system.

## SPECIFICATION

SPECIFICATION	SKYE 5	SKYE 5	SKYE 7	SKYE 7
Fuel	Wood logs	Smokeless Fuel	Wood logs	Smokeless Fuel
Rated Heat Output kW (BTU/hr)	5.0	5.0	7.0	7.0
Stove Weight kg (Packed)	136 (Low) 155	136 (Low) 155	157 (Low) 177	157 (Low) 177
Flue Temperature °C	239	247	284	291
Minimum Flue Draught	12Pa	12Pa	12Pa	12Pa
Flue gas Mass Flow g/s	3.4	4.0	5.9	5.0
Hearth Temperature	<100	<100	<100	<100
<b>Minimum distance from combustibles mm</b>	<b>SKYE 5</b>		<b>SKYE 7</b>	
	<b>SIDE</b>	<b>REAR</b>	<b>SIDE</b>	<b>REAR</b>
With Uninsulated Flue	300	270	350	350
With Insulated Flue and rear Heat shield	200	90	350	100
The outputs in the table are based on a 45 minute re-fuelling cycle burning seasoned hardwood logs. All tests are carried out in accordance with BSEN 13240.				



## CHIMNEY

In order for the appliance to perform satisfactorily the chimney height must not be less than 4 metres measured vertically from the outlet of the stove to the top of the chimney. The internal dimensions of the chimney should preferably be 150-200 mm (6" - 8") either square or round and **MUST NOT BE LESS THAN 125 mm (5")** - Skye 5 or 150 mm (6") - Skye 7.

If an existing chimney is to be used it must be swept and checked, it must be in good condition, free from cracks and blockages, and should not have an excessive cross sectional area. If it was previously used by an open fire then the chimney should be swept one month after installation to clear any soot falls which may have occurred due to the difference in combustion between the stove and the open fire. If you find that the chimney is in poor condition then expert advice should be sought regarding the necessity of having the chimney lined. If it is found necessary to line the chimney then a lining suitable for Solid Fuel must be used.

If there is no existing chimney then a prefabricated block chimney or a twin walled insulated stainless steel flue to BSEN 15287-1:2007 can be used either internally or externally. These chimneys must be fitted in accordance with the manufacturers instructions and Building Regulations.

Single wall flue pipe is suitable for connecting the stove to the chimney but is not suitable for using for the complete chimney. If it is found that there is excessive draw in the chimney then a draught stabiliser should be fitted.

It is important that there is sufficient draw in the chimney and that the chimney does not suffer from down-draught. When the chimney is warm the draw should be not less than 1.25mm (0.05") water gauge (12 Pa). If in doubt about the chimney seek expert advice.

## HEARTH AND FIRE SURROUND

The stove must stand on a fireproof hearth and must not be situated closer than the minimum distance from combustible materials (see specification table) to the sides or rear above hearth level unless adequately fireproofed in accordance with local building regulations. The hearth must be of fireproof material and at least 12mm (1/2in.) thick. The positioning of the stove and the size of the hearth are governed by building regulations for Class 1 appliances. These building regulations state that the hearth must extend in front of the stove by at least 225mm (9 in.) and to the sides of the stove by at least 150mm (6 in.). When the fire door is open, it extends beyond

the flat front of the stove by 430mm - Skye 5 or 480mm - Skye 7.

If in doubt as to the positioning of the stove, expert advice should be sought either from the supplier or the local building inspector. The fireplace must allow good circulation of air around the appliance to ensure that maximum heat is transferred to the room and also to prevent the fireplace from overheating. A gap of 150mm (6") each side and 300mm (12") above the appliance should give sufficient air circulation. If a wooden mantelpiece or beam is used in the fireplace it should be a minimum of 460mm (18"), and preferably 600mm (24") from the appliance. In some situations it may be necessary to shield the beam or mantelpiece to protect it.

In order for the fire to operate correctly and to allow for access, there must be an air gap behind the appliance of at least 50mm, but be aware that this distance will need to be greater in some cases to meet Building Regulation requirements.

The appliance should be installed on a floor with adequate load-bearing capacity. If an existing construction does not meet this requirement then please take suitable measures to achieve this. (e.g. load distributing plate.)

## CONNECTIONS TO FLUES

The stove must be connected to the flue using flue pipe of the following sizes:

125mm (5") diameter - Skye 5. 150mm (6") diameter - Skye 7.

This may be stainless steel, cast iron, or thick wall steel pipe. Straight lengths of Charnwood Pipe to match the stove are available if required. If using twin wall flue, the flue spigot must be shielded to protect exposed combustible material. This can be done with a shielded starter length of flue.

There are several ways of connecting the stove to the flue. These are illustrated in Figs. 7 to 10.

If the top flue connection or optional vertical rear flue connector is used then the chimney may be swept through the appliance.

A spacer (part 77, pages 20-21) is required to attach the optional vertical rear flue connector to the Skye 7.

Horizontal lengths of flue must be kept to a minimum and should not be more in length than the flue diameter.

The stove comes with the blanking plate (fig. 11) fitted to the top

# INSTALLATION INSTRUCTIONS



flue outlet. The seal for the top outlet is a 155mm dia ring of rope seal. The seal for the rear outlet is a length of adhesive backed fibre webbing supplied with instructions ref: TIS093. This is applied to the flue collar or the Vertical Rear Flue adapter for rear outlet installations. For top outlet installations, the blanking plate must be removed, have the webbing fitted to its sealing face, and fitted to the rear flue outlet. Ensure that the fold on the clamping plate is in line with the lugs on the firebox as shown in Fig 11. Ensure that the clamping plate does not prevent the throat plate from seating correctly. All flue connections must be well sealed. The top outlet connection is made directly to the cast top, the Skye is supplied with a flue collar for rear outlet installations.

**Fig.7. Vertical register plate with bricked up fireplace**

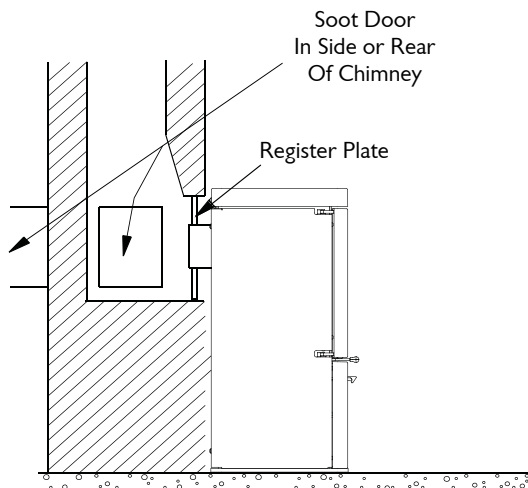

**Fig.8. Horizontal register plate with rear flue connection**

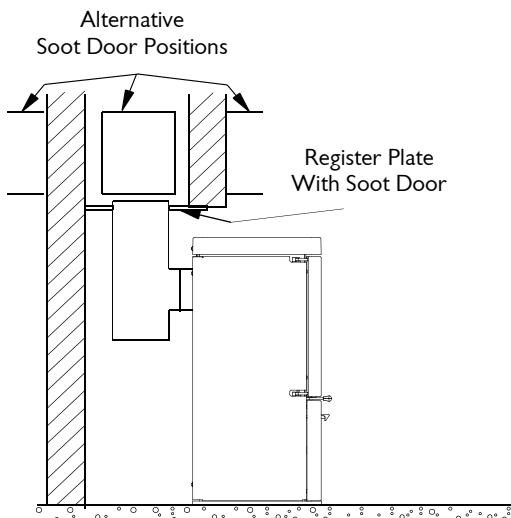

**Fig. 9. Horizontal register plate with top flue connection**

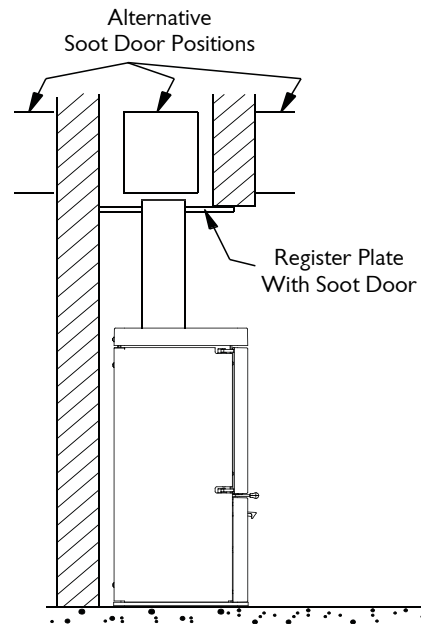

**Fig. 10. Horizontal register plate with optional vertical rear flue connector**

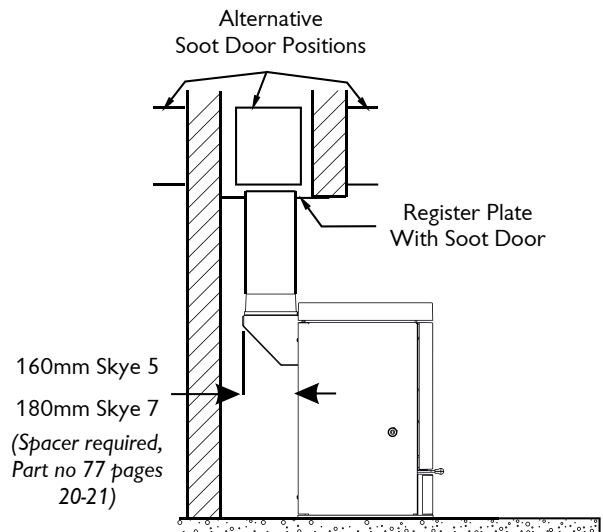

## SOOT DOORS

It is possible to pass a 16 inch diameter sweeps brush through the appliance but in most back outlet installations it will be necessary to have a soot door to enable the chimney to be swept. The optional vertical rear flue connector does allow the chimney to be swept through the stove. Soot doors may either be in the actual brickwork of the chimney or in the register plate. Various positions of soot doors are shown in Figs. 7 to 10.



**Fig. 11. Flue Blanking Plate**

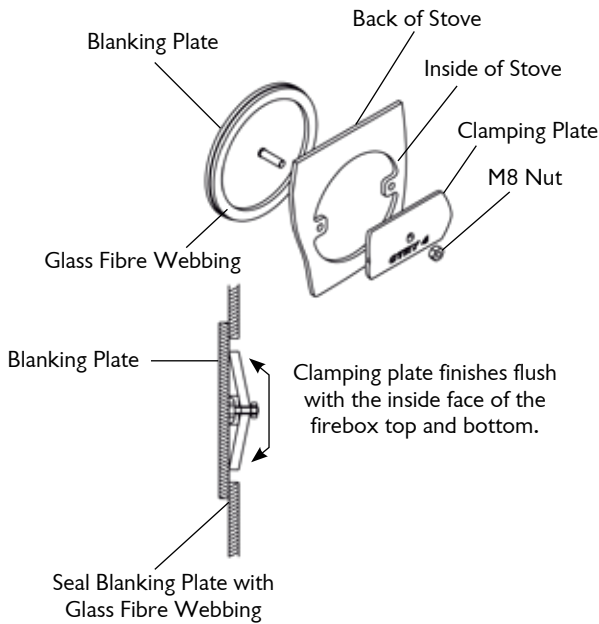

## PRE LIGHTING CHECK

Ensure that upper throat plate (Skye 7, top flue outlet connection only) and the throat plate is fitted in the roof of the appliance. The location and positioning of the throat plate is shown in Fig. 6.

Check that the front fence is fitted correctly and that the door closes properly.

## COMMISSIONING

On completion of the installation allow a suitable period of time for the fire cement and mortar to dry out before lighting the fire. Make a layer of ash or sand on the base of the stove before lighting. Check to ensure that smoke and fumes are taken from the appliance up the chimney and emitted safely. Also check all joints and seals. On completion of the installation and commissioning please leave the operating instructions with the customer and advise them on the use of the appliance.

Flue draught can be checked by removing the bolt that is located to the right of the rear flue exit behind the rear panel (Skye 5) or removing the bolt underneath the front left hand side (Skye 7)

## FITTING THE REAR HEAT SHIELD

The Skye is supplied with an optional rear heat shield. When fitted to the back of the stove it will reduce the rear distance to combustibles:

**Skye 5:** 90mm **Skye 7:** 100mm

To fit the optional rear heat shield, loosen the button head allen screws and slide the heat shield on so that the slots on the back of the heat shield fit over the screws. (fig. 12)

**Fig. 12. Fitting the optional rear heat shield.**

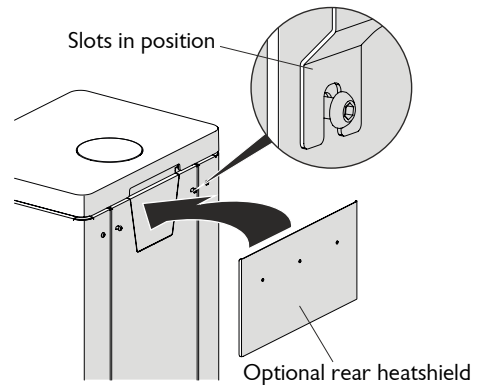

## CAA AND SMOKE CONTROL

The Clean Air Act 1993 and Smoke Control Areas

Under the Clean Air Act local authorities may declare the whole or part of the district of the authority to be a smoke control area. It is an offence to emit smoke from a chimney of a building, from a furnace or from any fixed boiler if located in a designated smoke control area. It is also an offence to acquire an “unauthorised fuel” for use within a smoke control area unless it is used in an “exempt” appliance (“exempted” from the controls which generally apply in the smoke control area).

In England appliances are exempted by publication on a list by the Secretary of State in accordance with changes made to sections 20 and 21 of the Clean Air Act 1993 by section 15 of the Deregulation Act 2015. Similarly in Scotland appliances are exempted by publication on a list by Scottish Ministers under section 50 of the Regulatory Reform (Scotland) Act 2014.

In Northern Ireland appliances are exempted by publication on a list by the Department of Agriculture, Environment and Rural Affairs under Section 16 of the Environmental Better regulation Act (Northern Ireland) 2016.

In Wales appliances are exempted by regulations made by Welsh Ministers.

Further information on the requirements of the Clean Air Act can be found here: <https://www.gov.uk/smoke-control-area-rules>

# INSTALLATION INSTRUCTIONS



Your local authority is responsible for implementing the Clean Air Act 1993 including designation and supervision of smoke control areas and you can contact them for details of Clean Air Act requirements.

The Skye 5 Store Stand and Skye 5 Low have been recommended as suitable for use in smoke control areas when burning wood logs.

The Skye 5 Store Stand and Skye 5 Low models include factory-fitted modifications to the air controls which have been designed to meet Clean Air Act requirements for smoke control Exemption.

# SKYE 5 DIMENSIONS

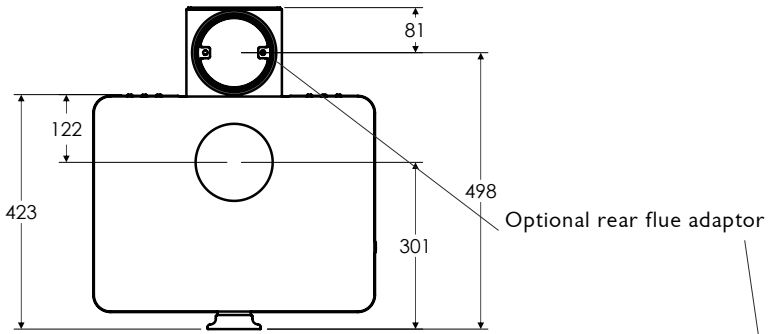

PLAN

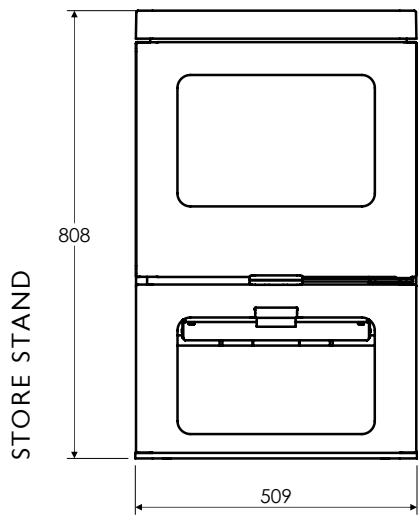

STORE STAND

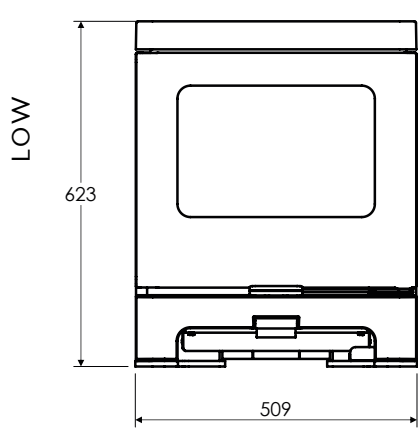
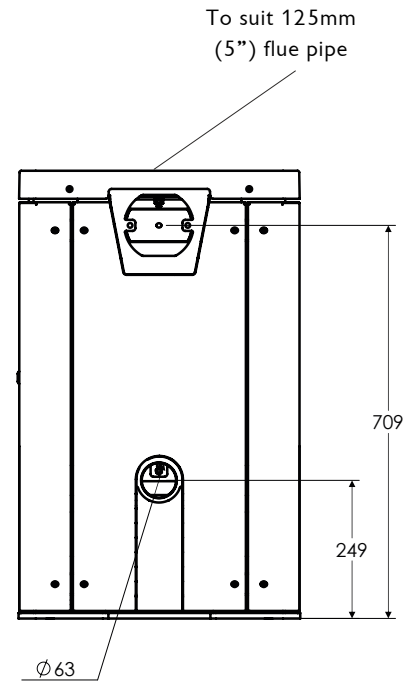
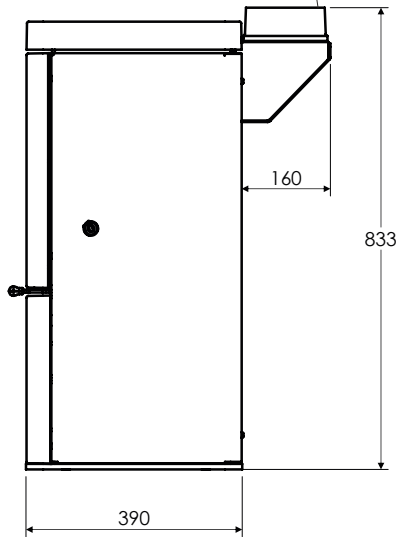

LOW

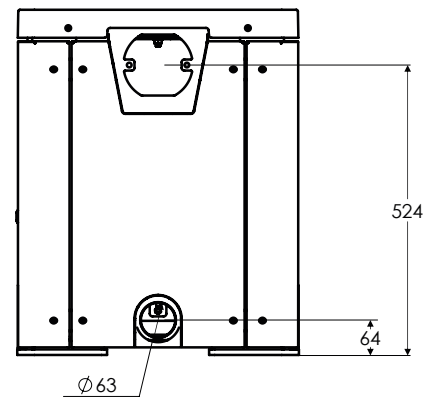
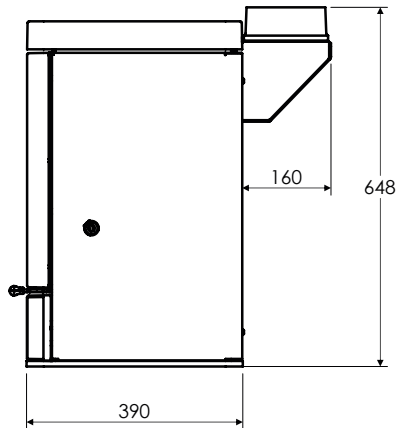

FRONT

SIDE

REAR



# SKYE 7 DIMENSIONS

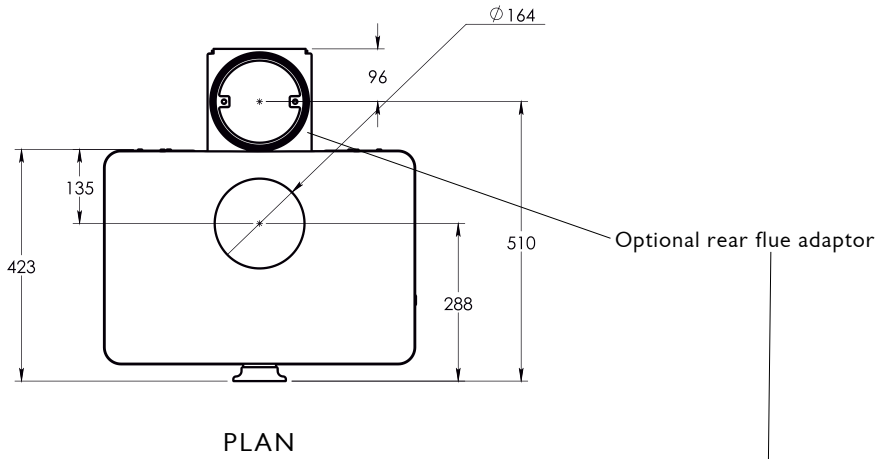

STORE STAND

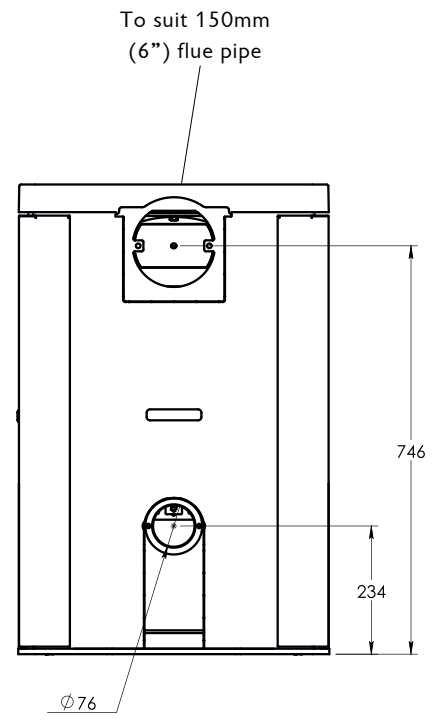
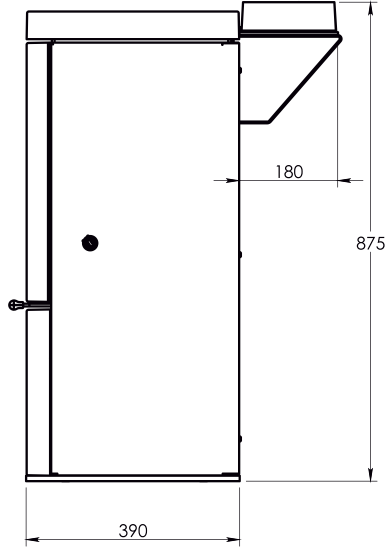
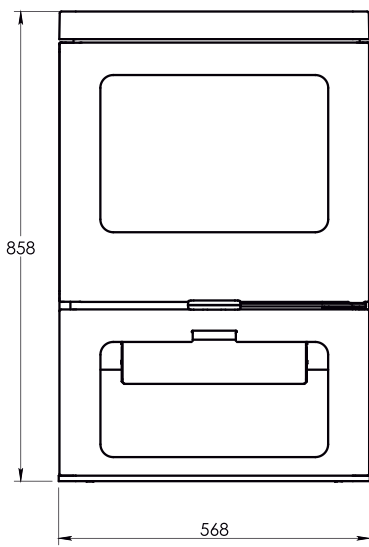

LOW

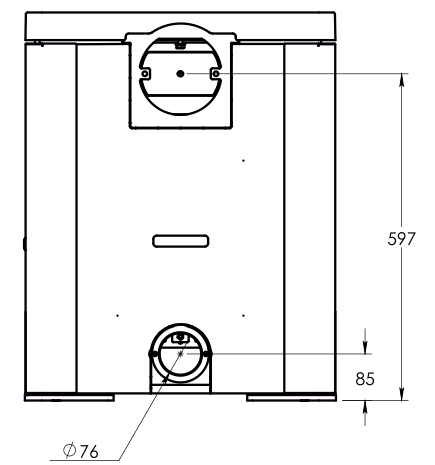
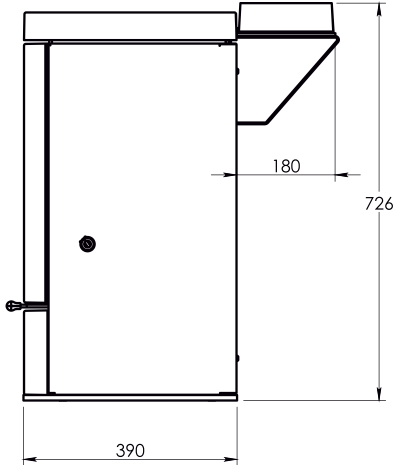
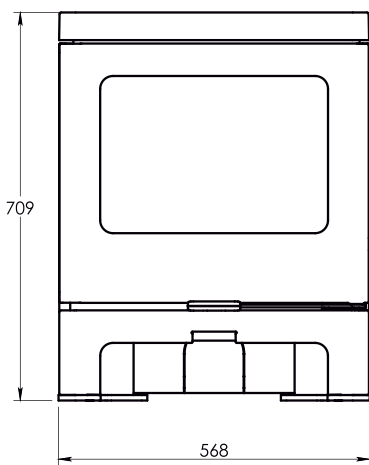

FRONT

SIDE

REAR

# Charnwood Skye 5 Store Stand Parts List



Issue C

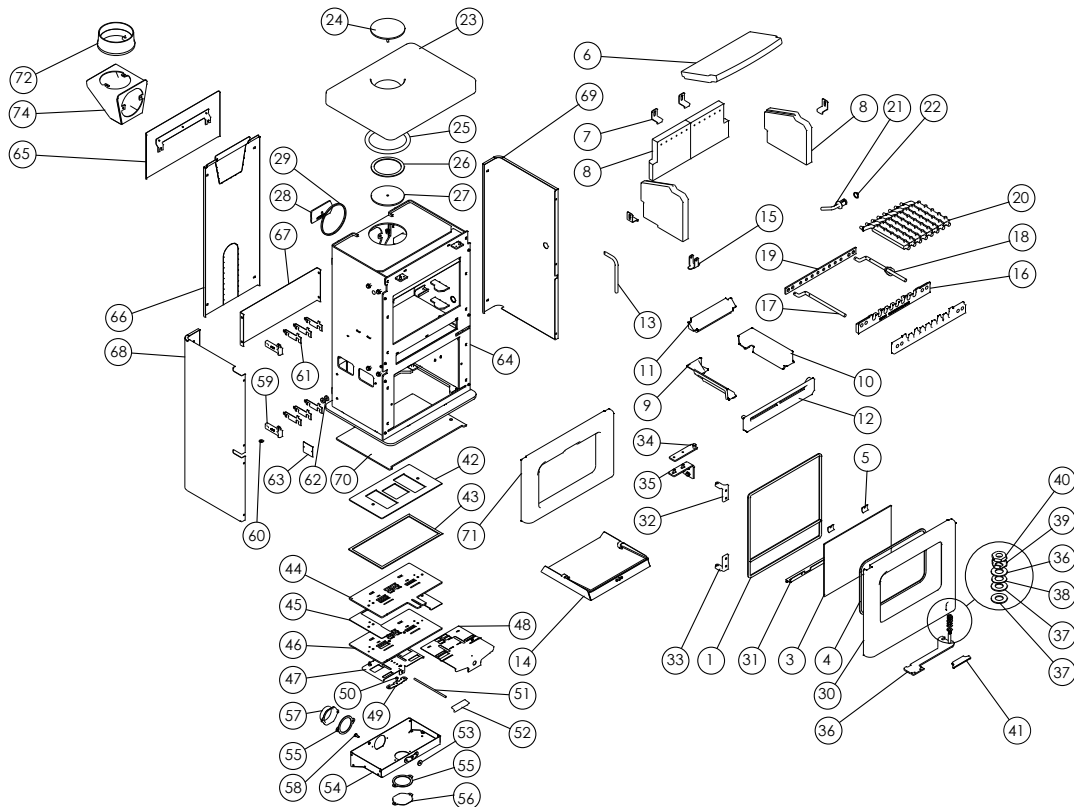

Item	Part No.	Description	Item	Part No.	Description
1	008/BU002/S	Rope Door Seal Inc Adhesive	38	008/FFW027	M10 Wavy Washer
2*	008/FW29	Door Seal Adhesive	39	010/BU061	Tabbed Locking Washer
3	006/BU018	Glass	40	008/FFN019	M10 Half Nut
4	008/BU003	Glass Seal	41	008/BU049	Door Handle
5	004/KV23	Glass Retainer	42	008/BU110	Air Control Gasket
6	011/BU031	Brick Throat Plate	43	008/EZ006	Airbox Gasket
7	004/XV30	Brick Bracket	44	010/BU111	Air Control Top Slider Plate
8	011/BU029S	Set of Firebricks	45	004/BU112	Wood/Multifuel Surround Plate
9	002/BU015L	LH Side Fire Plate	46	010/BU130	Air Control Lower Plate
10	002/BU015R	RH Side Fireplate	47	004/BU115	Air Control Slider
11	002/BU016	Back Fireplate	48	004/BU113	Wood/Multifuel Selection Slide
12	002/BU007	Front Fence	49	004/BR015	Clicker Retainer Plate
13	004/EZ095	Ashpan/Riddling Tool	50	008/ES36/01	Brass Ball Catch
14	004/BU017	Ashpan	51	004/ER016	Control Rod
15	010/BU097	Carrier Bar Clamping Bracket	52	008/BU037	Air Control Handle
16	002/BU030	Carrier Bar	53	008/BR052	Felt Washer
17	012/AY13	Idler Rod	54	004/BU120	Air Box Cover
18	010/BU077	Riddler Rod Assembly	55	008/BR044	Duct Gasket
19	010/BU033	Mover Bar	56	004/BR054	Blanking Plate
20	002/CG20S8	Set of Grate Bars (8)	57	004/BR053	Air Inlet Spigot
21	002/BU098	Riddler Spigot	58	008/FFS067	Defra Stop
22	008/FFM081	Circlip	59	002/BU040	Door Hinge Bracket
23#	002/BU009	Cast Top	60	008/FFW024	M8 Brass Washer
24	010/BU012	Blanking Plate	61	004/BU039	Door Hinge Shim
25	008/BU004	Flue Fixing Rope Seal	62	010/DY24	Spacer
26	008/KS134	Blanking Plate Seal	63	012/BU011	Serial No. Label
27	010/BU019	Blanking Plate Retainer	64#	001/BU010	Firebox
28	010/EY51	Clamping Plate	65#	010/BU081	Rear Heatshield
29#	010/BU013	Top Flue Trim Ring	66#	004/BU080	Rear Panel
30#	003/BU001A	Door Casting	67#	004/BU059	Rear Lower Panel
31	004/BU050	Rope Seal Channel	68#	004/BU093L	Left Side Panel
32	002/BU041	Upper Hinge	69#	004/BU093R	Right Side Panel
33	002/BU042	Lower Hinge	70#	010/BU058	Base Plate
34	010/BU063	Door Latch	71#	002/BU072	Front Casting
35	010/BU064	Door Latch Bracket	72#	002/PV12B	Flue Collar
36#	010/BU060	Door Catch Arm	73	010/EW51	Ash Carrier (Optional Extra)
37	008/FFW029	M10 Brass Washer	74#	010/BU034	Vertical Rear Flue Adapter (Opt'l Extra)

\*These items are not shown on the drawing.  
# Please specify colour when ordering.

To obtain spare parts please contact your local stockist giving Model, Part No. and Description. In case of difficulty contact the manufacturer at the address shown. This drawing is for identification purposes only.

# Charnwood Skye 5 Low Parts List

Issue B

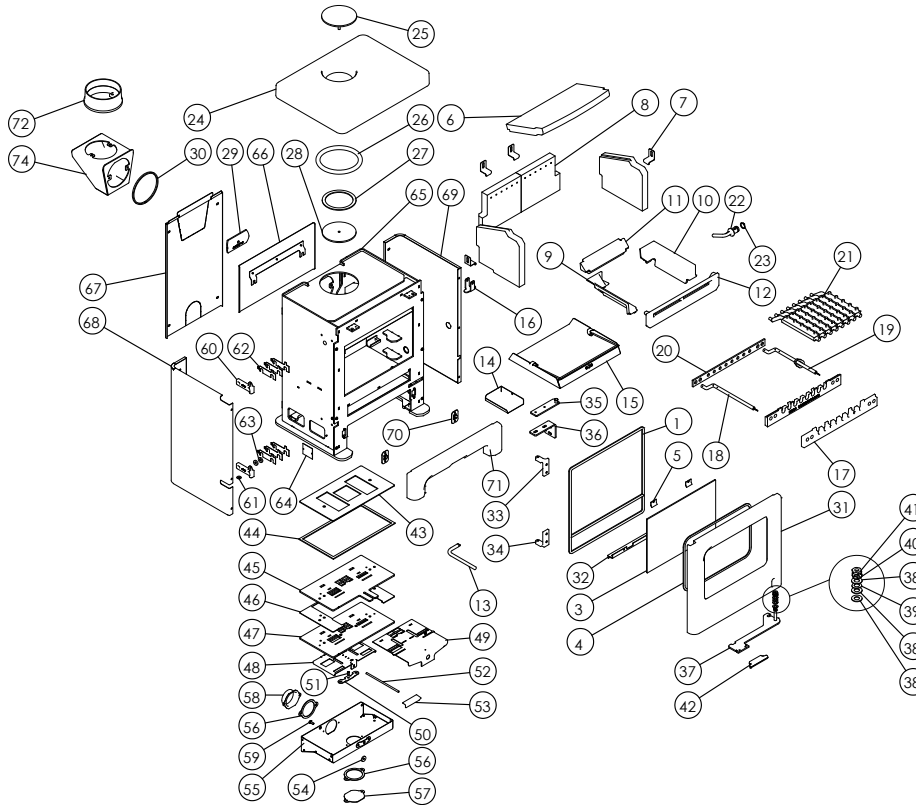

Item	Part No.	Description	Item	Part No.	Description
1	008/BU002/S	Rope Door Seal Inc Adhesive	38	008/FFW029	M10 Brass Washer
2*	008/FW29	Door Seal Adhesive	39	008/FFW027	M10 Wavy Washer
3	006/BU018	Glass	40	010/BU061	Tabbed Locking Washer
4	008/BU003	Glass Seal	41	008/FFN019	M10 Half Nut
5	004/KV23	Glass Retainer	42	008/BU049	Door Handle
6	011/BU031	Brick Throat Plate	43	008/BU110	Air Control Gasket
7	004/XV30	Brick Bracket	44	008/EZ006	Airbox Gasket
8	011/BU029S	Set of Firebricks	45	010/BU111	Air Control Top Slider Plate
9	002/BU015L	LH Side Fire Plate	46	004/BU112	Wood/Multifuel Surround Plate
10	002/BU015R	RH Side Fireplate	47	010/BU130	Air Control Lower Plate
11	002/BU016	Back Fireplate	48	004/BU115	Air Control Slider
12	002/BU007	Front Fence	49	004/BU113	Wood/Multifuel Selection Slide
13	004/EZ095	Ashpan/Riddling Tool	50	004/BR015	Clicker Retainer Plate
14	004/BUL048	Ashpan/Riddling Tool Holder	51	008/ES36/01	Brass Ball Catch
15	004/BU017	Ashpan	52	004/ER016	Control Rod
16	010/BU097	Carrier Bar Clamping Bracket	53	008/BU037	Air Control Handle
17	002/BU030	Carrier Bar	54	008/BR052	Felt Washer
18	012/AY13	Idler Rod	55	004/BU120	Air Box Cover
19	010/BU077	Riddler Rod Assembly	56	008/BR044	Duct Gasket
20	010/BU033	Mover Bar	57	004/BR054	Blanking Plate
21	002/CG20S8	Set of Grate Bars (8)	58	004/BR053	Air Inlet Spigot
22	002/BU098	Riddler Spigot	59	008/FFS067	Defra Stop
23	008/FFM081	Circlip	60	002/BU040	Door Hinge Bracket
24#	002/BU009	Cast Top	61	008/FFW024	M8 Brass Washer
25	010/BU012	Blanking Plate	62	004/BU039	Door Hinge Shim
26	008/BU004	Flue Fixing Rope Seal	63	010/DY24	Spacer
27	008/KS134	Blanking Plate Seal	64	012/BUL011	Serial No. Label
28	010/BU019	Blanking Plate Retainer	65#	001/BUL010	Firebox
29	010/EY51	Clamping Plate	66#	010/BU081	Rear Heatshield
30#	010/BU013	Top Flue Trim Ring	67#	004/BUL080	Rear Panel
31#	003/BU001A	Door Casting	68#	004/BUL093L	Left Side Panel
32	004/BU050	Rope Seal Channel	69#	004/BUL093R	Right Side Panel
33	002/BU041	Upper Hinge	70	004/BUL089	Front Casting Reciever
34	002/BU042	Lower Hinge	71#	002/BUL071	Front Casting
35	010/BU063	Door Latch	72#	002/PV12B	Flue Collar
36	010/BU064	Door Latch Bracket	73	010/EW51	Ash Carrier (Optional Extra)
37#	010/BU060	Door Catch Arm	74#	010/BU034	Vertical Rear Flue Adapter (Opt'l Extra)

\*These items are not shown on the drawing.

# Please specify colour when ordering.

To obtain spare parts please contact your local stockist giving Model, Part No. and Description. In case of difficulty contact the manufacturer at the address shown.

This drawing is for identification purposes only.

# Charnwood Skye 7 Store Stand Parts List



Issue A

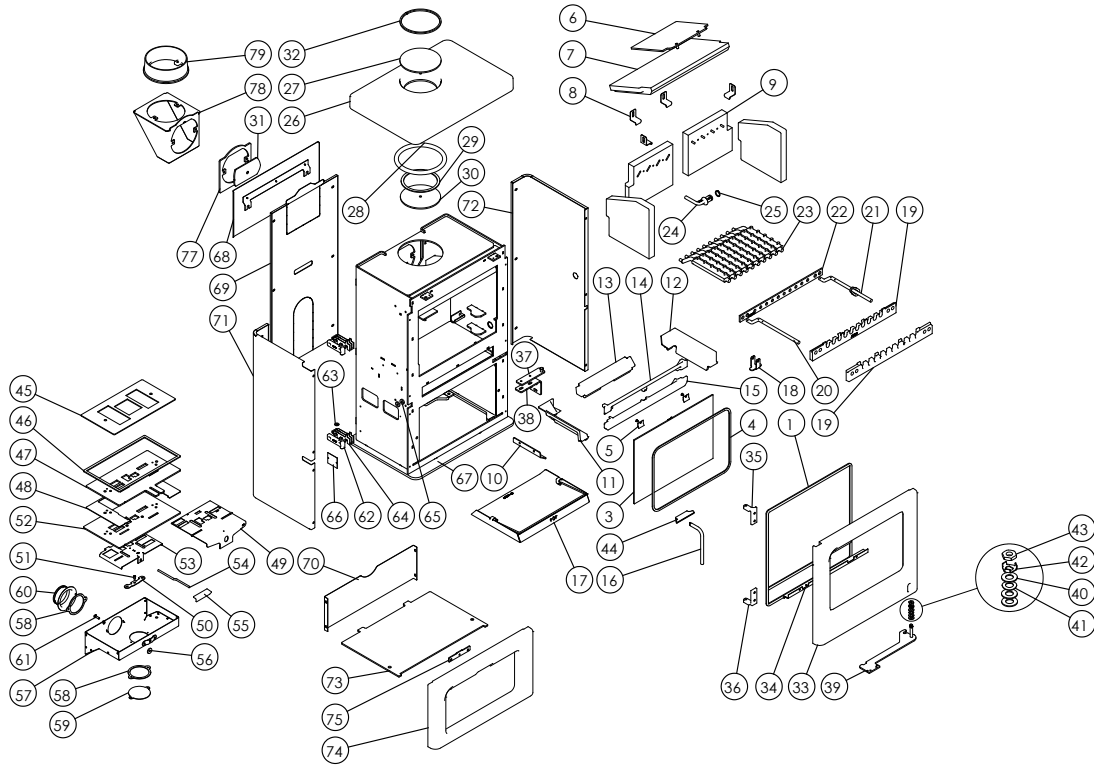

Item	Part No.	Description	Item	Part No.	Description
1	008/AU002/S	Rope Door Seal Inc Adhesive	41	008/FFW027	M10 Wavy Washer
2*	008/FW29	Door Seal Adhesive	42	010/BU061	Tabbed Locking Washer
3	006/AU018	Glass	43	008/FFN019	M10 Half Nut
4	008/AU003	Glass Seal	44	008/BU049	Door Handle
5	004/KV23	Glass Retainer	45	008/BU110	Air Control Gasket
6	010/AU032	Upper Throat Plate	46	008/KZ006	Air Box Gasket
7	011/AU031	Brick Throat Plate	47	010/AU111	Air Control Top Slider Plate
8	004/XV30	Brick Bracket	48	004/AU112	Undergrate Slider Spacer
9	011/AU029S	Set of Firebricks	49	004/AU113	Multifuel Selection Slider
10	010/AU019	Undergrate Deflector	50	004/BR015	Clicker Retainer Plate
11	002/BU015L	LH Side Fire Plate	51	008/ES36/01	Brass Ball Catch
12	002/BU015R	RH Side Fireplate	52	010/AU130	Air Control Lower Plate
13	002/AU016	Back Fireplate	53	004/AU115	Air Control Slider
14	002/AU008	Deepening Bar	54	004/AU013	Air Control Rod
15	002/AU007	Front Fence	55	008/BU037	Air Control Handle
16	004/EZ095	Ashpan/Riddling Tool	56	008/BR052	Felt Washer
17	004/AP017	Ashpan	57	004/KZ039	Air Box Cover
18	010/BU097	Carrier Bar Clamping Bracket	58	008/CR063	Duct Gasket
19	002/AY30	Carrier Bar	59	004/CR064	Blanking Plate
20	012/AY13	Idler Rod	60	004/CR048	Air Inlet Spigot
21	010/BU077	Riddler Rod Assembly	61	008/FFS067	Defra Stop
22	010/AU033	Mover Bar	62	002/BU040	Door Hinge Bracket
23	002/CG20S10	Set of Grate Bars (10)	63	008/FFW024	M8 Brass Washer
24	002/BU098	Riddler Spigot	64	004/BU039	Door Hinge Shim
25	008/FFM081	Circlip	65	010/DY24	Spacer
26	002/AU009	Cast Top	66	012/AU011	Serial No. Label
27	010/KZ132	Blanking Plate	67#	001/AU010	Firebox
28	008/AU004	Flue Fixing Rope Seal	68#	010/AU081	Rear Heatshield
29	008/KZ134	Blanking Plate Seal	69#	004/AU080	Rear Panel
30	010/KZ133	Blanking Plate Retainer	70#	004/AU059	Rear Lower Panel
31	010/AY51	Clamping Plate	71#	004/AU093L	Left Side Panel
32#	010/KZ131	Top Flue Trim Ring	72#	004/AU093R	Right Side Panel
33#	003/AU001	Door Casting	73#	010/AU058	Base Plate
34	004/AU050	Rope Seal Channel	74#	002/AU072	Front Casting
35	002/BU041	Upper Hinge	75	010/AU014	Air control rod guide
36	002/BU042	Lower Hinge	76	010/EW51	Ash Carrier (Optional Extra)
37	010/BU063	Door Latch	77#	010/AU021	Vertical Rear Flue Adapter Spacer
38	010/BU064	Door Latch Bracket	78#	010/TW33	Vertical Rear Flue Adapter (Opt'l Extra)
39#	010/AU060	Door Catch Arm	79	008/CH12B	Flue Collar
40	008/FFW029	M10 Brass Washer			

\*These items are not shown on the drawing.

# Please specify colour when ordering.

To obtain spare parts please contact your local stockist giving Model, Part No. and Description. In case of difficulty contact the manufacturer at the address shown.

This drawing is for identification purposes only.

# Charnwood Skye 7 Low Parts List



Issue A

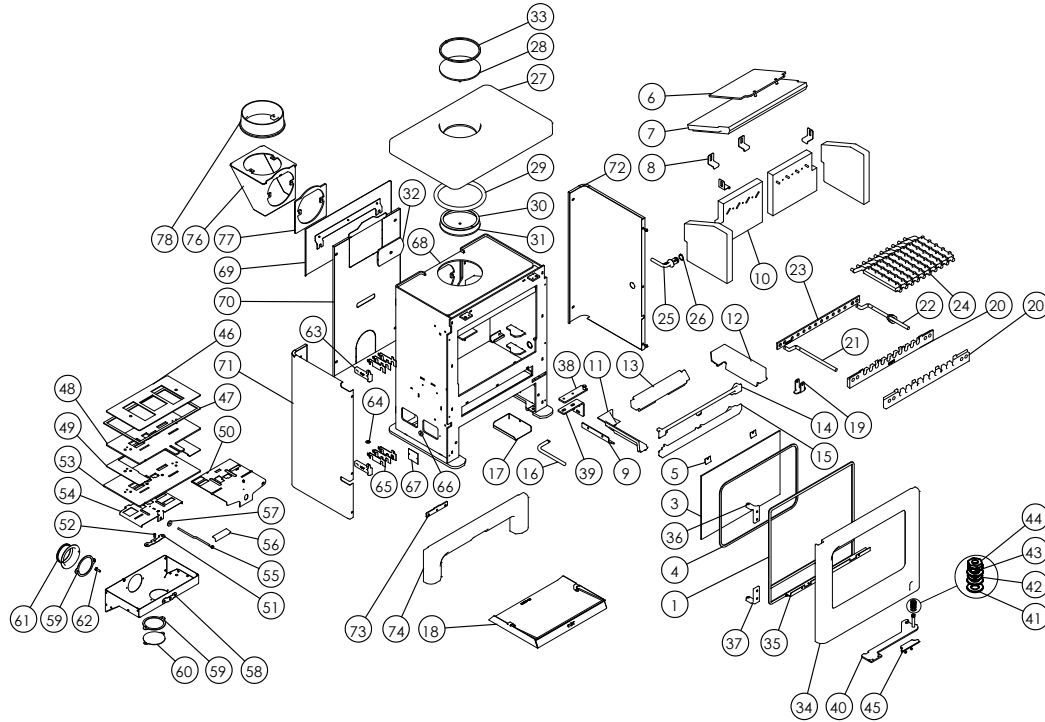

Item	Part No.	Description	Item	Part No.	Description
1	008/AU002/S	Rope Door Seal Inc Adhesive	40#	010/AU060	Door Catch Arm
2*	008/FW29	Door Seal Adhesive	41	008/FFW029	M10 Brass Washer
3	006/AU018	Glass	42	008/FFW027	M10 Wavy Washer
4	008/AU003	Glass Seal	43	010/BU061	Tabbed Locking Washer
5	004/KV23	Glass Retainer	44	008/FFN019	M10 Half Nut
6	010/AU032	Upper Throat Plate	45	008/BU049	Door Handle
7	011/AU031	Brick Throat Plate	46	008/BU110	Air control gasket
8	004/XV30	Brick Bracket	47	008/KZ006	Air box gasket
9	010/AU019	Undergrate Deflector	48	010/AU111	Air Control Top Slider Plate
10	011/AU029S	Set of Firebricks	49	004/AU112	Undergrate Slider Spacer
11	002/BU015L	LH Side Fire Plate	50	004/AU113	Multifuel Selection Slider
12	002/BU015R	RH Side Fireplate	51	004/BR015	Clicker Retainer Plate
13	002/AU016	Back Fireplate	52	008/ES36/01	Brass Ball Catch
14	002/AU008	Deepening Bar	53	010/AU130	Air Control Lower Plate
15	002/AU007	Front Fence	54	004/AU115	Air Control Slider
16	004/EZ095	Ashpan/Riddling Tool	55	004/AU013	Air Control Rod
17	004/BUL048	Tool Holder Tray	56	008/BU037	Air Control Handle
18	004/AP017	Ashpan	57	008/BR052	Felt Washer
19	010/BU097	Carrier Bar Clamping Bracket	58	004/KZ039	Air Box Cover
20	002/AY30	Carrier Bar	59	008/CR063	Duct Gasket
21	012/AY13	Idler Rod	60	004/CR064	Blanking Plate
22	010/BU077	Riddler Rod Assembly	61	004/CR048	Air Inlet Spigot
23	010/AU033	Mover Bar	62	008/FFS067	Defra Stop
24	002/CG20S10	Set of Grate Bars (10)	63	002/BU040	Door Hinge Bracket
25	002/BU098	Riddler Spigot	64	008/FFW024	M8 Brass Washer
26	008/FFM081	Circlip	65	004/BU039	Door Hinge Shim
27#	002/AU009	Cast Top	66	010/DY24	Spacer
28	010/KZ132	Blanking Plate	67	012/AUL011	Serial No. Label
29	008/AU004	Flue Fixing Rope Seal	68#	001/AUL010	Firebox
30	008/KZ134	Blanking Plate Seal	69#	010/AU081	Rear Heatshield
31	010/KZ133	Blanking Plate Retainer	70#	004/AUL080	Rear Panel
32	010/AY51	Clamping Plate	71#	004/AUL093L	Left Side Panel
33#	010/KZ131	Top Flue Trim Ring	72#	004/AUL093R	Right Side Panel
34#	003/AU001	Door Casting	73	010/AU014	Air Control Rod Guide
35	004/AU050	Rope Seal Channel	74#	002/AUL072	Front Casting
36	002/BU041	Upper Hinge	75*	010/EW51	Ash Carrier (Optional Extra)
37	002/BU042	Lower Hinge	76#	010/TW33	Vertical Rear Flue Adapter (Opt'l Extra)
38	010/BU063	Door Latch	77	010/AU021	Vertical Rear Flue Adapter Spacer
39	010/BU064	Door Latch Bracket	78#	008/CH12B	Flue Collar

\*These items are not shown on the drawing.  
# Please specify colour when ordering.

To obtain spare parts please contact your local stockist giving Model, Part No. and Description. In case of difficulty contact the manufacturer at the address shown.  
This drawing is for identification purposes only.



# charnwood



**AJ WELLS & SONS LTD**

**19**

*Bishops Way, Newport, Isle Of Wight PO30 5WS, United Kingdom*  
 A Division of A.J.Wells & Sons Limited Registered In England No. 03809371  
 CE certificate for compliance with EN13240:2001

## EN13240:2001

### ROOMHEATERS FIRED BY SOLID FUEL

Model:	SKYE 5	SKYE 5	SKYE 7	SKYE 7
EC Certificate of conformity no:	BU44-CPD-2017 BUL44-CPD-2017	BU44-CPD-2017 BUL44-CPD-2017	AU44-CPD-2017 AUL44-CPD-2017	AU44-CPD-2017 AUL44-CPD-2017
Fuel type:	WOOD LOGS	SOLID FUEL	WOOD LOGS	SOLID FUEL
Rated space heating thermal output:	5kW	5kW	7kW	7kW
Emission of CO in combustion products:	0.06%	0.10%	0.05%	0.08%
Mean flue gas temperature:	239°C	247°C	284°C	291°C
Energy efficiency:	86%	82%	80%	81%
Particles (mg/m <sup>3</sup> <sub>n</sub> )	25	13	22	8
Minimum distance to combustible materials with uninsulated flue				
Side:	300	300	350	350
Rear:	270	270	350	350
Minimum distance to combustible materials with insulated flue & rear heat shield				
Side:	200	200	350	350
Rear:	90	90	150	150
Fulfilled requirements: BStV of the City of Munich and the City of Regensburg FBStVO of the City of Aachen and the City of Düsseldorf 1.and 2. level of 1. BlmSchV of	✓	✓	✓	✓



*your premier dealer*

**charnwood** BISHOPS WAY, NEWPORT, ISLE OF WIGHT PO30 5WS, UNITED KINGDOM  
TEL. +44 (0) 1983 537777 • FAX. +44 (0) 1983 537788 • [WWW.CHARNWOOD.COM](http://WWW.CHARNWOOD.COM)

A Division of A.J. Wells & Sons Limited Registered in England No. 03809371