

The Hollington Stove Range

By **Si**



Background

The Si stove range was conceived from the desire to exceed the existing requirements of Eco-Design 2022 comfortably and constantly with a design that avoids the common disadvantages of ultra-high efficiency stoves.

Hands on installation of many eco-design ready stoves showed them to have a susceptibility to fluing issues and widespread problems with excessive smoke spillage into the room during refuelling. It was apparent that there was a considerable need in the market for a stove that uses innovative technology to avoid these problems whilst also not just meeting but exceeding current eco-design regulations.



Looking at the basics of stove design, the way to increase efficiency is the make the stove flue outlet more restrictive and slow down the flue gas termination.

This has the effect of increasing the output of the stove and raised the efficiency. As the baffle of the stove is made more restrictive, the tendency is for the stove to spill smoke and fumes when the door is opened for refuelling. Additionally, the heat passing into the flue is greatly reduced, the flue becomes slower to warm up, and in extreme cases never become hot enough to function as required. Cooler flues are also prone to increased flue deposits and condensation. The correct balance of efficiency and flue performance in a stove is essential to provide a user friendly and reliably operating stove that can perform safely and effectively on a wide variety of flues and chimneys.



The Design

The Si range used a radical, innovative design to create a combustion and fluing dynamic that provides an overall efficiency which exceeds the requirement of Eco-Design 2022, along with low flue emissions all substantially lower than the Eco-Design limits.

This is all achieved without the issues of poor flue performance and spillage of flue gases into the room during refuelling. Clean combustion is primarily achieved by using an exactly metered balance of combustion air to both the rear and front of the combustion chamber. The rate of air to this chamber is controlled by a single long travel lever, facilitating simple and precise adjustment of the burn rate and heat output. The combustion air passes through a full width duct through the rear of the stove and then over the top of the combustion chamber. These are the hottest parts of the stove, and the incoming combustion air is pre heated to an extremely high temperature. This high velocity air curtain then passes over the face of the door glass, preventing flame impingement on the glass and effectively burns away any deposits even where wood has been allowed to come into direct contact with the glass. As this pre heated air flows onto the burning fuel, its extreme temperature avoids the chilling of the combustion process and generates intense incandescence and radiant heat. The high combustion temperatures achieved reduce particulate and Co emissions even on a minimal rate of burning.



Indoor Air Quality

Eco-Design 2022 was brought in to ensure a minimum standard of efficiency for new log burning and multifuel stoves and boilers. Whilst this takes into consideration heat output and smoke produced from the flue it overlooks indoor air quality and smoke spillage into the room.

The Si stove concept was conceived from the need to exceed the requirements of Eco-Design 2022 comfortably and consistently, but with a design that avoids the disadvantages of ultra-high efficiency stoves. Primarily excessive smoke spillage into the room during refuelling.

With the growing awareness of indoor air quality and health which we believe has previously been ignored by other stove manufacturers, it was apparent that there was a considerable need in the market for a stove which not only complied with current regulations but did so whilst keeping the user's indoor air quality in mind.

Introducing...

Si *FlueBoost*
TECHNOLOGY



A highly innovative feature which includes two large flue vents that are uncovered when the door is opened, thereby removing smoke and dust during refuelling.

This patent pending technology is robust and uses no moving parts or mechanisms which can jam or seize over time, a common problem with other mechanical flue dampers when subjected to high temperatures.

This feature is designed into all of our stoves and allows us to produce stoves that burn cleanly and efficiently when under normal conditions but also greatly reduce smoke spillage into the room when the doors are opened for refilling.

The Benefits

The most obvious benefit to our range of stoves is a stunning dancing flame picture with intense incandescence seen through a crystal-clear glass.

The high temperature and velocity of the air curtain takes clear burning glass to a whole new level even under low burn rates. Radiant heat output through the stove glass is exceptionally high and provides comforting direct warmth to the room. Further user benefits include the single, long travel control which is user friendly and simple to use providing precise control over the stoves output. Finally, the "flue boost" baffle will ensure the user has substantially reduced spillage to the room whilst refuelling.

Less tangible but equally important benefits are the low emissions of particulates and other pollutants in the burnt flue gasses, achieved without sacrificing operation on a wide range of flue types. Effective afterburning and optimum flue temperatures ensure minimal flue deposits and avoid condensation issues. The "flue boost" baffle system and surrounding area can easily be inspected and cleaned without the need to remove the baffle through the vents at the front of the appliances opening.

The flue baffle geometry is designed to provide a high level of efficiency without creating a torturous path for the burnt gasses to be expelled. The flue gasses will always rise as they pass through the baffle system and exit the appliance. This will combat smoking back commonly reported during the lighting or the initial ignition phase especially on those cold, still days when the chimney is cold.

The combination of the above features along with the fully insulated base of these dedicated wood burning stoves results in extremely effective combustion of the wood. Our high combustion temperatures and metred pre heated combustion air enable the wood to burn by gasification. This means that your wood will burn very cleanly and for much longer, especially on medium to lower heat settings. This ensures a reduced use of fuel whilst benefiting from an increased efficiency over a sustained period.



Hollington 5 Dimensions

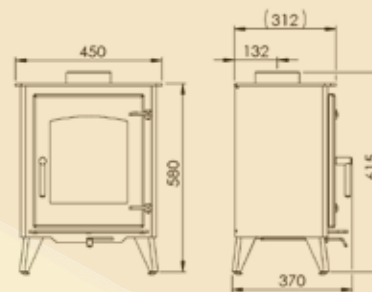

Hollington 5b Dimensions

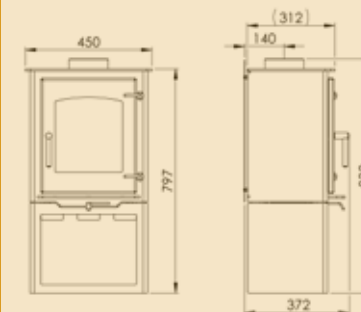

Hollington 8 Dimensions

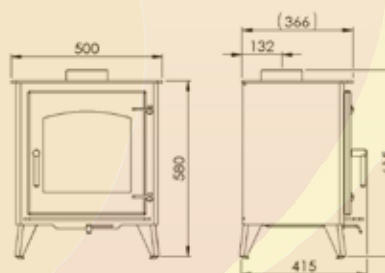

Hollington 8b Dimensions

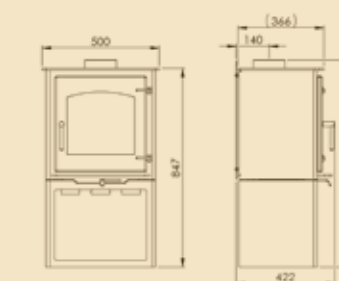

Product Specification	5	5lb	8	8lb
Nominal heat output	5kW	5kW	6kW	6kW
Maxheat output	7.5kW	7.5kW	10kW	10kW
Min heat output	2.5kW	2.5kW	3.8kW	3.8kW
Min clearanceto combustiblerear wall (with Heat Shield)	75mm	75mm	75mm	75mm
Recommended minimum clearance to non-combustible rear wall	25mm	25mm	25mm	25mm
Min side clearance to combustible materials	600mm	600mm	600mm	600mm
Recommended minimum clearance to non-combustible sides	40mm	40mm	40mm	40mm
Flue outlet size	129mm	129mm	129mm	129mm
Room vent required	No	No	Yes	Yes
Eco design 2022 compliant	Yes	Yes	Yes	Yes
SI "flue boost" technology	Yes	Yes	Yes	Yes
Super-heated air wash	Yes	Yes	Yes	Yes
Fuel type	Wood	Wood	Wood	Wood
Max. Log length	380mm	380mm	430mm	430mm
Construction	Seam welded steel	Seam welded steel	Seam welded steel	Seam welded steel
Doubleskinned combustion chamber	Top and rear	Top and rear	Top and rear	Top and rear
Guarantee (Stove body warranty)	10 year	10 year	10 year	10 year

Efficient, clean burning, high quality stoves with a stunning flame picture viewed through a crystal-clear glass.

With over 50 years' industry experience designing and fitting stoves we have decided to use our knowledge to produce a new type of wood burning stove with fundamental improvements to classic log burners.

Our stoves are designed to burn efficiently and cleanly but also consider INDOOR air quality as well as flue emissions. Up to now we feel this factor has been overlooked by government regulations (Eco-Design 2022) and most other stove manufacturers.

We pride ourselves on the fact that all our stoves are designed and built to the highest quality; this includes key design aspects such as double skinned combustion chambers with thicker grade steel and ensuring all joints are fully seam welded instead of tack welded.

After many years' experience of fitting stoves, we also know small design considerations can make a big difference during installation. Something as simple as having easily accessible height adjustment on the legs can be the difference between lifting a stove into position once or multiple times.

All our products are designed, manufactured and assembled in the UK.



Introducing the New Hollington Boiler Stoves



Following the successful launch of the Si5 and Si8 dry stove range, it became apparent that there was an opportunity to build on the success of the unique features of these products and incorporate them into completely new boiler stoves designed to pass the stringent new Eco-Design 2022 regulations. The new regulations require high levels of efficiency and low flue emissions compared with those achieved by boiler stoves made prior Eco-Design 2022.

Stove Innovations started with a smaller boiler stove based on the size of the Si8 dry stove and approached design of the new boiler stove with a completely new layout and heat exchanger. This utilises a unique tube-based heat exchanger to provide a high surface area for heat transfer, whilst being compact enough to be located above the combustion chamber. It extracts the heat from the hot flue gases without chilling the combustion of the fuel in the main chamber, which allows the fuel to burn cleanly more like a dry stove.

The Si12 boiler stove was type tested and passed Eco-Design requirements in March 2023 for both woodburning and solid fuel operation. The Si12 produces a maximum total heat output of 12kW with 6.2kW going to water and 5.8kW to the room. This is suitable for heating a small property or for link-up systems for topping up a larger system alongside another boiler.

The successful approval of this model was followed by the development of a large high output boiler stove. This utilises the same principles as the smaller Si12 but with a larger firebox and substantially more complex heat exchanger featuring both larger tubes and insulated side and rear flat heat exchangers. Due to the high heat output required whilst maintaining sensible refuelling intervals, this product has been initially designed as a solid fuel boiler stove suitable for burning all approved smokeless fuels.

Si12 Boiler Stove Dimensions

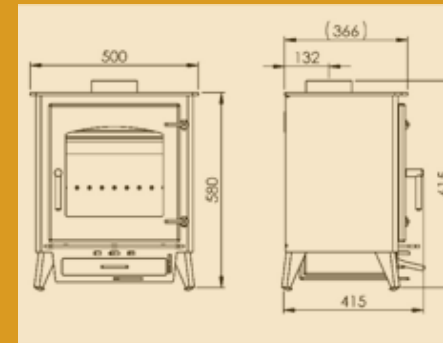

Si20 Boiler Stove Dimensions

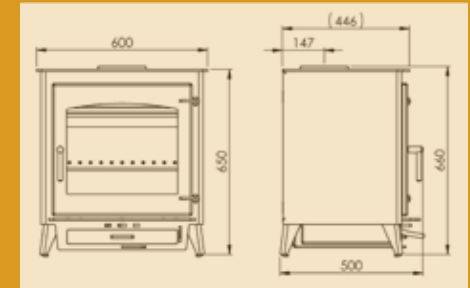

	Si12	Si20
Nominal Total Heat Output	9.9kW	13kW
Nominal Heat Output (to Water) (to Room)	4.1kW 5.8kW	6.7kW 6.3kW
Maximum Heat Output	12kW	20kW
Maximum Heat Output (to Water) (to Room)	6.2kW 5.8kW	12.5kW 7.5kW
Clearance to Combustible Rear Wall	200mm	100mm
Recommended Minimum Wall Clearance to Non Combustible Rear	75mm	75mm
Wall Clearance to Combustible sides	350mm	600mm
Recommended Minimum Wall Clearance To Non-Combustible Sides (for access to parts)	75mm	75mm
Room Vent Required	Yes	Yes
Eco-Design 2022 Compliant	Yes	Yes
Heating System Requirements	Indirect Open Vented	Indirect Open Vented
SuperHeated Air Wash	Yes	Yes
Fuel Type	Wood/Smokeless Fuel	Wood/Smokeless Fuel
Log Length	400mm	450mm
Construction	Seam welded steel	Seam welded steel
Double skinned combustion chamber	Top and rear	Top and rear
Guarantee	10YearStoveBody Guarantee	10YearStoveBody Guarantee

Stove Innovations

www.sistoves.co.uk

Tel: 01782 914169

Email: info@sistoves.co.uk