



# Si 12

## Wood and Solid Fuel Boiler Stove



**Installation and User Instructions**

# IMPORTANT INFORMATION

## APPLIANCE INFORMATION

	Si12
Nominal Total Heat Output	9.9kW Wood
Nominal Heat Output (to Water) (to Room)	4.1kW 5.8kW
Maximum Heat Output	12kW
Maximum Heat Output (to Water) (to Room)	6.2kW 5.8kW
Clearance to Combustible Rear Wall	200mm
Recommended Minimum Wall Clearance to Non Combustible Rear	75mm
Wall Clearance to Combustible sides	350mm
Recommended Minimum Wall Clearance To Non- Combustible Sides (for access to parts)	75mm
Flue Outlet Size (Top Outlet Only)	125mm
Minimum Flue Size	150mm (6")
Vent Required	Yes
Tappings	2 x 1" BSP
Heating System Requirements	Indirect Open Vented
Fuel Type	Wood /Smokeless Fuel
Log Length	400mm
Construction	Seam Welded Steel
Double Skinned Combustion Chamber	Top and Rear
Guarantee	10 Year Stove Body Guarantee

## APPLIANCE DIMENSIONS Si 12

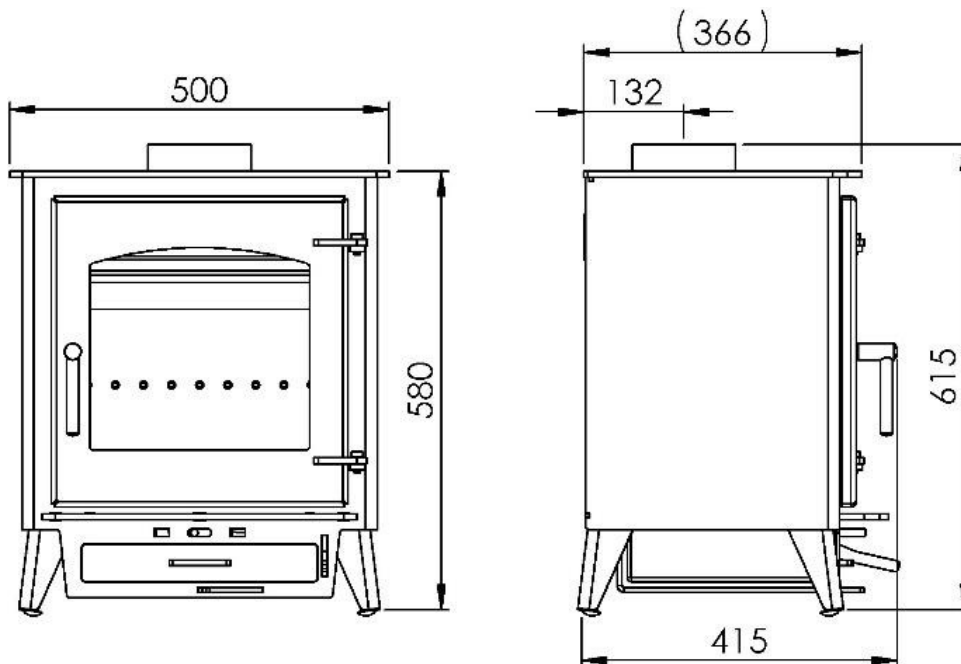

## CONDITIONS OF INSTALLATION

It is the law that all wood fired heating appliances are installed in accordance with Building Regulations and that local authority Building Control approval is obtained for the installation. This can be done through a qualified installer who is part of an approved Competent Persons scheme (and who is able to self-certify his work) or by obtaining approval through a building inspector. Failure to install appliances correctly could lead to prosecution. It is in your own interest and that of safety to comply with the law.

The installation must also be in accordance with all relevant parts of the Local and National Building Regulations where appropriate, the Building Regulations (Scotland Consolidation) issued by the Scottish Development Department, and all applicable requirements of the relevant British Standard Code of Practice.

### Hearth Suitability

The stove must only be installed on a full constructional and superimposed hearth that is constructed and sized in accordance with Document J of the Building Regulations.

### Fire Openings

Fire openings and recesses must be constructed of non-combustible material in accordance with Building Regulations unless the internal surfaces are further away from the stove than the minimum clearances to combustibles stated in this manual. If "boarding out" the internal faces of a suitable fire opening it is recommended that fire board of minimum thickness of 12mm is used that is capable of withstanding prolonged high temperatures to avoid cracking.

### Combustible Materials

Any combustible materials must not be closer to the stove than the minimum clearances stated in the table at the back of this booklet.

### Ventilation

Si 12 stove models have a nominal heat output of 9.9kW and require additional permanent ventilation. When installed in houses built prior to 2008, the stove requires a permanent vent with a total free area of at least 2750mm<sup>2</sup>. When installed in properties built after 2008 the Si 12 stove requires ventilation of 4400mm<sup>2</sup>. The siting of the vent should be carried out to minimise cross-room draughts.

If a draught stabiliser is fitted to any of the stove models then the ventilation should be increased in line with Document J of the Building Regulations.

### Flue and Chimney Suitability

These appliances are designed for use with conventional brick built or lined chimneys and fabricated flues. All flues must conform to the following minimum dimensions.

<b>Minimum diameter of circular flues</b>	<b>150mm (6") flue</b>
<b>Minimum effective height of all flue types</b>	<b>5 metres</b>

## Flue / Chimney Suitability

Before commencing installation, a flue or chimney should be inspected to ensure that all the following conditions are satisfied.

- Check that the chimney / flue only serves one fireplace and is clear of any obstruction. Any dampers or register plates must be removed or locked in the open position.
- Any chimney or flue which has been used for an appliance burning fuel other than gas must be thoroughly swept before using.
- **These appliances are high efficiency and are not suitable for use in unlined masonry chimneys.** The heat loss through the structure of a masonry chimney and resulting low flue temperatures will cause poor flue draft and increase the risk of condensation, flue deposits and chimney fires. We strongly recommend that masonry chimneys are lined with a 6" (150mm) 316 or 904 grade solid fuel flexible flue liner to avoid condensation and prevent flue debris falling onto the appliance flue outlet. If solid fuel is to be used then we recommend that only 904 grade flexible liners are used to reduce the likelihood of sulphur attacking the liner.
- A cleaning door must be provided on the connecting flue pipe to allow sweeping.
- **Using a smoke pellet, check that there is an up-draught in the chimney / flue and that the smoke can be seen issuing from the terminal / chimney pot outside. There must be no leakage of smoke through the structure of the chimney during or after the smoke pellet test and it is important to check inside upstairs rooms adjacent to the chimney / flue.** Check the chimney pot / terminal and general condition of the brickwork or masonry. If the chimney or flue is in poor condition or if there is no up-draught do not proceed with the installation without first rectifying the problems.
- As with any stove installation, it is advisable to check the location of the chimney termination for height and location with regard to roof features, ridges and adjacent structures or trees. Even compliant chimneys can cause problems in certain wind directions due to turbulence caused by these features. Any concerns should be raised with the customer prior to the installation taking place.
- The hot flue draught of the finished installation should be between 10 and 24 pascals. Inadequate flue draught will result in poor performance and smoking whereas excessive flue draught will result in excessive firing of the stove.

## **Heating System Suitability**

The Si 12 stove is a low output boiler stove designed to replace back boiler stoves or open fires or fur use as additional heating as part of a “linked up” system alongside an additional boiler or appliance.

**The stove must only be connected to indirect open vented systems with permanently open separate feed and expansion pipes.**

**A permanent gravity circulation must be provided with a heat leak radiator to provide a constant total heat load.**

**It is important to control the returning water temperature as part of the system to avoid pumped cold return water causing condensation in the boiler. This is achieved with the use of a low limit thermostat as part of the system.**

**The stove has two 1” BSP tappings on the top rear of the stove body. The flow tapping is higher than the return and is on the left-hand side of the stove when viewed from the front. The return tapping is lower and is located on the right-hand side of the stove when viewed from the front. It is important to connect these tappings correctly to facilitate gravity flow and venting of any air from the stove.**

A drain valve should always be provided below the return tapping pipe run to facilitate future draining of the system / boiler.

System design should be in accordance with current best practice for solid fuel heating systems. There are a number of proprietary link-up systems available and if these are used then the suppliers instructions should be followed.

On a conventional gravity and pumped solid fuel system it is recommended that the gravity circuit is piped up using 28mm copper pipe and that no valves or obstructions are present on the flow or return pipes or feed or expansion pipes to avoid any possibility of catastrophic pressure build up due to inadvertent closure of valves.

Gravity pipes should rise all the way to the vent position to avoid air locks and facilitate effective gravity flow through the pipes.

## **Unpacking and Disassembly**

Remove the outer carton sleeve and top fitment, and the cardboard plug from the flue outlet. Open the stove door and pull the cardboard transit wedges from between the side fire lining panels and the removable cleaning baffle at the top rear of the firebox. The stove gloves, quick start guide, tube cleaner, scraper tool and ash pan handle are located in the ash pan below the grate.

It is recommended that all loose items from inside the stove are removed to lighten the stove and allow easier positioning of the stove in the final location.

Lift out the vermiculite woodburning grate insert from its transit position. To do this, carefully tilt it sideways as far as possible then carefully withdraw it from the stove. Below this are the solid fuel hard refractory grate bricks. These should also be lifted out and stored safely. The 8mm steel front ash retainer can be lifted up at the right-hand side and withdrawn from the front of the stove.

There are 8 cast iron grate bars that are located on the rocker bar at the front and are identical bars which are alternatively located front to rear such that every other bar reciprocated backwards and forwards when the riddling lever is actuated. These should all be lifted off at the front and withdrawn from the stove. The ashpan is taped at each side for transit and the tape can now be removed and the ashpan withdrawn from the fire. To further lighten the stove, the door can be lifted off the hinge blocks and safely stored along with the two door pins for refitting later. The only remaining loose item is the rear flue cleaning baffle. This is located at the top rear of the firebox and has a steel peg on the lower centre which can be gripped to pull the baffle forwards off the retaining lugs. It can then be rotated forwards at one side to allow it to drop down off the top of the side fire lining panels. This will have considerably lightened the stove for moving.

The stove is secured to the wooden pallet with four No 2 posidrive screws and steel strips hooked over the adjustable feet. These need to be removed before removing the stove from the pallet.

If trucking the stove after removal from the pallet, be careful not to damage the lower air control which is underneath the ash pit of the stove.

### **Locating and Connecting the Stove**

The stove should be located on the hearth with sufficient space behind the stove to allow connection of the flow and return pipes. Depending on the elbows used, 75mm should be adequate to do this. It is best to pre-make the connecting pipe runs prior to final positioning.

The stove should be levelled with the adjustable feet on each leg. This should spin down by hand and can be finally positioned with an 11mm spanner.

The connecting 5" flue pipe should be connected with a shouldered male spigot downwards into the flue outlet and sealed with fire cement and glass fibre tape. A cleaning door must be provided to allow sweeping of the flue as this cannot be done through the stove.

## Re-assembly of the Stove

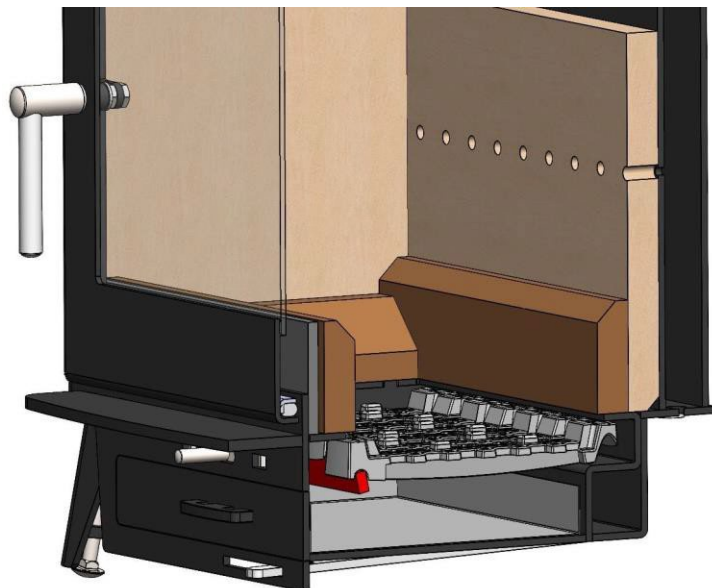

Refit the eight grate bars alternatively positioned with the heavy end in the recesses on the rocker bar and the light end on the “turrets” of the rocker bar.

If the side and rear chamber lining panels have been removed, fit the rear lining panel first at the rear of the firebox so the holes line up with the tertiary air holes in the steel rear panel. Fit each side panel with the large cut out on the top front.

The steel cleaning baffle should be refitted by gripping the peg and positioning one end of the baffle above the rear of the side panel and rotating the other end backwards over the opposite side panel. Both ends should then be pushed fully backwards to securely locate on the steel retaining lugs.

Fit the rectangular steel ash retaining panel, this is held in place by the side firebox lining panels and can be removed or refitted by lifting the right-hand side until it is released from behind the side lining panels.

If the stove is to be used on solid smokeless fuel, then the four hard refractory firebricks should be positioned in the grate as shown in the cut-away diagram above. This is important as these protect the steel base of the stove around the ashpit from the high temperatures generated when burning solid fuel.

If the stove is to be used for burning wood, then the solid combustion chamber base panel should be fitted instead of the firebricks. This insulating panel fully covers the grate area and allows a thick bed of insulating charcoal to build up. This provides effective operation of the stove on wood. The primary air slider is rendered ineffective when this is in place as the wood combustion is regulated by the secondary air control lever below the ashpit door.

Check the ashpan is securely located in the aperture to prevent air leakage.

## Commissioning

Commissioning checks should be carried out in line with the guidance of the relevant competent persons scheme and their commissioning check list form filled in. The checks should include flue pull, heating system performance and any thermostat settings. This will

involve running the system until equilibrium is achieved and ensuring that operation is satisfactory. Check and bleed radiators and make sure they are correctly balanced.

Ensure that a CO alarm is supplied and correctly positioned and fitted, and that a fireguard conforming to BS 8423:2010+A1:2016 is used if children or old or infirm people are present.

Explain the operation of the controls to the customer and explain usage of the stove gloves supplied when operating the stove as all parts get hot during use.

Make sure the installation is registered with the relevant competent persons scheme and a certificate of compliance is generated.

## **Using the Stove**

### **Basic Operation of an Si 12 Boiler Stove When Burning Wood**

- Si12 stoves are wood burning or solid fuel stoves. They are designed to burn wood with the insulating tile fitted over the grate bars in place of the hard refractory firebricks. The insulating tile retains the heat and importantly, allows a thick bed of glowing charcoal to build up underneath the burning logs rather than dropping away through the grate. This is crucial as it causes the logs to burn more efficiently and with intense heat.
- When burning wood with the insulating tile in place, the Si 12 stoves utilise the single long travel control lever, which delivers perfectly balanced pre-heated combustion air to the burning wood and provides precise control over the burn rate and heat output of the stove. The lever is located below the centre of the ash box of the stove. The lever moves from left (the minimum setting) to right (the maximum setting). The primary air control located above the ashpit has no effect when the insulating tile is in place.
- When burning wood, ash will only normally need removing every week or so even with regular use. A thick bed of embers always provides the best fire, the ash only needs emptying when it is well up the front ash retaining panel.
- To remove excess ash, make sure the stove is fully cold, (embers can still be glowing next morning inside the charcoal layer). Lift the front ash retaining plate vertically and slide a flat based ash shovel underneath it and scoop up the excess ash. Some ash will remain at the corners, and this can be spread out as a thin layer before lighting the next fire.
- Wood must be clean and dry (with a moisture content below 20%). This is now a legal requirement.
- The “flue boost” system is unique to Si stoves and will help to draw smoke and dust up the flue when the door is opened for refuelling. Always open the door slowly to allow the air to enter progressively and avoid a sudden rush.
- If burning wood, it is important to avoid slumbering fires as this will result in excessive chilling of the boiler and accelerate build-up of



deposits on the boiler surfaces and tubes. Tube cleaning will need to be carried out more frequently when burning wood.

## Basic Operation of an Si 12 Boiler Stove When Burning Smokeless Solid Fuel

- **The insulating tile that is in place above the grate bars should be removed for solid fuel operation.** The 4 hard refractory bricks should be fitted in place to protect the area around the grate bars. This allows the ash to fall through the grate bars and operation of the riddling lever to shake ash through the grate.
- With the tile removed, and the hard refractory bricks in place, the stove is ready to burn solid fuel. The fuel must be an approved smokeless solid fuel, **traditional house coal must not be used.**
- When burning solid fuel, both air controls are utilised. The top control located below the ash lip of the stove controls primary air and moves from left (minimum) to right (maximum). This controls the air flowing up through the grate underneath the fuel bed. The lower control located below the ash pit door of the stove controls secondary and tertiary air which flows in through holes in the rear firebrick and down the door glass to provide a super-heated air wash to keep the glass clear. On solid fuel operation some staining of the glass can occur with certain fuels. This can be minimised by keeping the burn rate brisk and not fully closing the lower control lever. This control also moves from left (minimum) to right (maximum).
- Depending on the make and type of smokeless fuel, ash will accumulate much faster than with wood and the ash pan will need checking and emptying regularly and always before the stove is lit. Ash must not be allowed to build up under the grate bars as this will cause them to overheat. To remove ash slide open the ash pan with the tool provided. This should always be done before the stove is lit. If the stove is hot the stove gloves must be worn. The ash should be immediately transferred to an enclosed steel container and left outside to cool. The ash pan must be immediately refitted and closed, making sure the closure panel is fully seated. This is important to prevent overheating.

## Lighting the Stove

- With a boiler stove it is essential to light it in a way which heats up the flue and boiler as fast as possible to reduce condensation. **Some condensation can form and drip in to the firebox when lighting from a cold start. This is normal with any boiler stove and is not a water leak.** This is best carried out with quality fire lighters and plenty of dry kindling. This applies to both wood and solid fuel fires. Plenty of dry kindling will heat up fast and warm the flue. The full user instructions online give detailed instructions on how to light and maintain a wood fire or solid fuel fire. When lighting the control lever(s) should be fully open to the right.
- Initially place a small amount of the chosen fuel in with the kindling and build it up gradually as it becomes established to avoid smothering the kindling.

- A boiler stove is best run with a hot fire to avoid excessive chilling by the boiler. Low or slumbering fires will result in more rapid clogging of the tubes, particularly with wood.

## Boiler and Tube Cleaning

- **As with any solid fuel boiler appliance it is essential that boiler and tubes are regularly checked and cleaned at least once a week.** This is essential for safe operation as blocked tubes or flues will cause flue products to leak out into the room. It will also maintain the efficiency of the stove. The tubes can easily be inspected and cleaned through the “flue boost” apertures above the firebox.
- Cleaning of the tubes can be carried out quickly and simply through the “flue boost” slots, which are above the firebox and can be accessed when the door is open. Boiler tubes should only be cleaned when the stove is not lit.
- To clean the tubes the door should be opened and the sliding baffle at the top rear of the firebox should be slid forwards by gripping the peg in the centre and sliding the baffle forwards off the locating lugs. It is only necessary to slide it forwards 100mm or so and it will rest on the top of the side bricks while cleaning is carried out. This will allow cleaning debris from the tubes to drop down onto the grate and removed.
- Once the baffle has been slid forward, the 8 tubes can be cleaned by pushing the wire tube cleaner into each tube in turn. The tube cleaner should be used to scrub the inside of the tube until it is clean. Regular cleaning makes this a quick and easy operation.
- Following cleaning of the tubes, the “question mark” shaped scraper should be used to clean the rear and top of the tube heat exchanger by holding the wooden handle and turning the tool sideways so it can be passed up behind the tubes. It can then be turned so the handle is pointing forwards and the scraped from side to side to clean the top and rear surfaces of the boiler. This is important to maintain flue operation and efficiency. The flat top edge of the tool can also be used to scrape the underside of the boiler to help maintain heat transfer.
- Once cleaning is completed, **the baffle plate should be slid fully back in to position and checked to make sure it is located up against the rear of the firebox.** Failure to do this will result in loss of efficiency as hot gases will leak up behind the tubes instead of being drawn through them.
- Any accumulated debris from cleaning can be riddled through the grate and emptied out of the ashpan before relighting the stove.

**Our spare parts distributors are Fire Spares Ltd and parts can be obtained from them at:**

**Fire Spares Ltd,**  
Unit 5 Wharnccliffe Business Park  
Middlewoods Way,  
Carlton,  
Barnsley,  
S71 3HR  
**Phone:** 01226 715 100  
**Email:** [info@firespares.co.uk](mailto:info@firespares.co.uk)  
**Website:** [www.firespares.co.uk](http://www.firespares.co.uk)

The rating plate of the stove is located on the rear of the stove. A copy of the appliance rating plate is stuck in the quick start guide supplied with the stove. Please retain this guide as the rating plate enables correct identification of your stove.

### **Stove Performance Data**

#### **Model: SI12 Boiler**

Fuel Type:	Wood	Solid Fuel
Nominal Heat Output:	9.9kW	6.4kW
Efficiency (Net):	82.8%	81.9%
Energy Efficiency Class:	A+	D
Mean Flue Gas Temperature:	183°C	204°C
Mean CO <sub>2</sub> Emissions:	8.45%	8.17%
Mean CO Emissions @13% O <sub>2</sub> :	0.07%	0.1%
Mean CH <sub>4</sub> Emissions @13% O <sub>2</sub> :	72mg/m <sub>o</sub> <sup>3</sup>	19mg/m <sub>o</sub> <sup>3</sup>
Mean NO <sub>x</sub> Emissions @13% O <sub>2</sub> :	127 mg/m <sub>o</sub> <sup>3</sup>	86 mg/m <sub>o</sub> <sup>3</sup>
Dust Emissions @13% O <sub>2</sub> :	36 mg/m <sub>o</sub> <sup>3</sup>	9 mg/m <sub>o</sub> <sup>3</sup>
Recommended Flue Draught:	10 – 24 pa	10 – 24 pa
Maximum Hearth Temperature:	65K	
Minimum Distance to Combustible Material		
Rear: (with twin wall flue adaptor):	200mm	
Side:	350mm	

Si 12 Installation and User Manual V.2

Stove Innovations Ltd,  
Shaw Top Farm, Upper Hulme, Leek, ST13 8UQ,

Telephone 01782 914169 E-Mail: [sistoves@outlook.com](mailto:sistoves@outlook.com)