

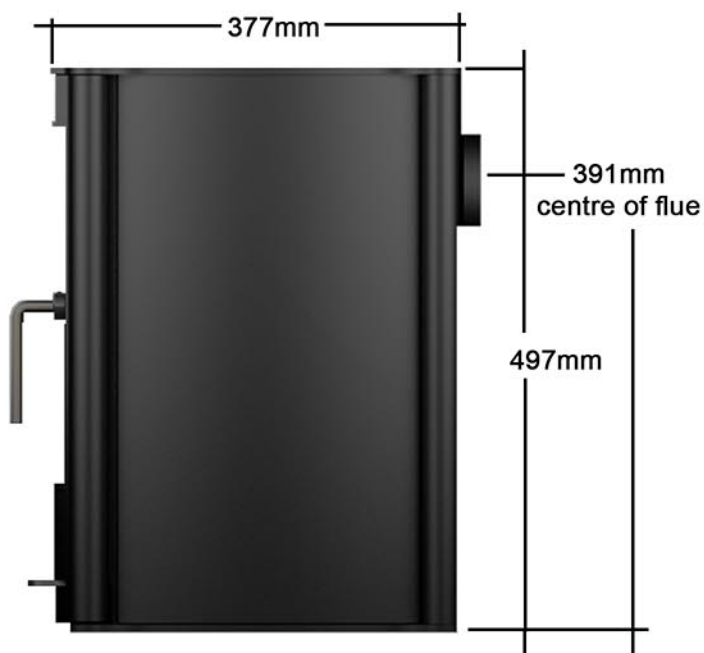

PRODUCT DATA

MODEL	FB Eco
WEIGHT	50KG
NOMINAL HEAT OUTPUT	4.8kw



STOVE SPECIFICATIONS

Material: Mild Steel

Sides of stove - 5mm thick

Bottom of stove - 5mm thick

Top of stove - 6mm thick

Fire Box lined with 25mm thick vermiculite

CONTENTS

OPERATING INSTRUCTIONS	
Lighting the fire	2
Firebox linings and baffle	2
Wood burning tips & theory	2
Running temperatures	3
Cleaning and Maintenance	3
M/F fitting instructions	
INSTALLATION INSTRUCTIONS	
Building regulations	4
Positioning and Clearances	4
Chimney	4
Flue connection	5
Problem solving	6

Operating Instructions

Building regulations

Installation of the Firebelly wood burning stove must comply with all local building regulations, including those referring to national and European standards. It is a good idea to consult your local chimney sweep to check the suitability of the chimney and ensure there is adequate updraft and suggest any remedies to potential chimney problems. Document J of the Building Regulations contains further information regarding the installation of solid fuel appliances and can be viewed here : www.odpm.gov.uk or follow the link on the Firebelly website.

Lighting the stove (Woodburning only)

When lighting the stove for the first time it should not be stoked excessively as all the materials must be given time to adapt to the effects of heat. The paint will take some time to fully cure and during this period some odours will be evident. It is recommended that doors or windows should be opened the first time the stove is fired.

Before lighting check the firebricks and other internal components are in position figure 1 and that all packaging has been removed.

Step 1 open the top air control and bottom air control fully. figure 2
(to open the top and bottom air controls slide the vents to the right hand side)

Step 2 Place rolled up and scrunched up newspaper at the back of the stove. Put small tinder on top of the newspaper and then a few slightly larger pieces of wood on top of this, light the newspaper and close the door.

Step 3 Let the fire burn until all the pieces of wood are alight and burning. Then more and larger pieces of wood/logs can be added.

Step 4 Once the fire is established the bottom air control can be closed so that all the air for the fire comes via the top air control. The burning rate of the fire can now be controlled by adjusting the top air control and by regulating the amount of wood added. The bottom air control should normally remain closed once the stove is running. If the fire has been allowed to die too low then the bottom air control can be opened to allow air to the base of the fire in an attempt to revive it.

Lighting the stove (Multi Fuel only)

When lighting the stove for the first time it should not be stoked excessively as all the materials must be given time to adapt to the effects of heat. The paint will take some time to fully cure and during this period some odours will be evident. It is recommended that doors or windows should be opened the first time the stove is fired.

Before lighting check the firebricks and other internal components are in position figure 1 and that all packaging has been removed.

Step 1 open the top air control and bottom air control fully. figure 2
Replace woodburning base plate with multi fuel rack, see fitting instructions.

Step 2 Place rolled up and scrunched up newspaper at the back of the stove. Put small tinder on top of the newspaper and then a few slightly larger pieces of wood on top of this, light the newspaper and close the door.

Step 3 Let the fire burn until all the pieces of wood are alight and burning. Then more and larger pieces of wood/logs can be added.

Step 4 As the fire becomes established solid fuel may now be added, the burning rate of the fire can be controlled by adjusting the bottom and top air controls and by regulating the amount of fuel added. The bottom air control should never be fully closed, as this helps with complete combustion. If the fire has been allowed to die down then the bottom air control should be fully re-opened.

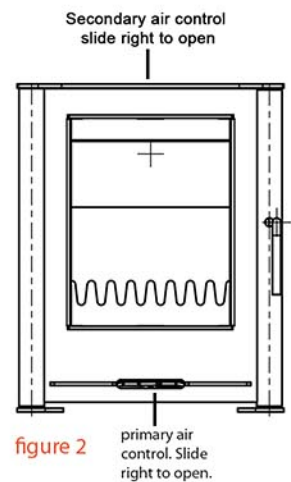
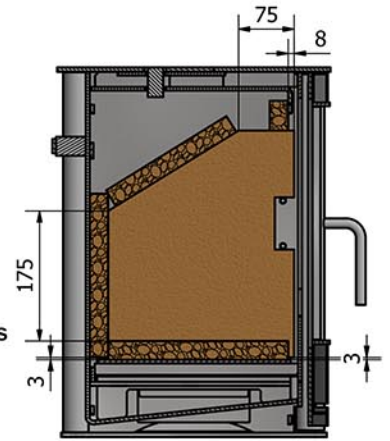

figure 2
primary air control. Slide right to open.

Do not run the stove with the door open

Warning.

The external surfaces of the stove become hot during operation. Use the supplied tool to operate the air controls when the stove is running.

Tips

The first stage of the fire, just after lighting, is usually the smokiest because the cold wood and cold stove take heat away from the flames. During this stage, ensure both air inlets of the stove are fully open to get a hot flame. It might appear that this initial hot burn lets too much heat go up the chimney, but it is a necessary part of an efficient fire. The extra heat "primes" the chimney to produce a strong draft, and helps keep the flue clean by loosening creosote that might have been deposited by the previous fire. The hot initial burn also drives moisture out of the firewood and gives an ignition source for the smoke that is released from the wood.

Make small changes. Do not try to add too much fuel at once, the fuel should not be stacked higher than the top of the back fire brick. Adding fuel gradually will help maintain a steady temperature and burning rate so that the stove burns efficiently and cleanly. Adding a large amount of fuel all at once will dramatically reduce the temperature inside the stove. After adding a large piece of wood/log it is a good idea to increase the top air opening slightly more until the new fuel begins to burn and the stove returns to temperature.

This also applies to the air controls. Adjusting them gradually will help maintain a steady combustion rate.

Do not run the stove with the top air control fully closed. The top air control supplies air for the glass 'air shield' system. The further open the top air control is the more effective the air shield system.

Use a piece of newspaper to wipe the inside of the window glass before lighting the stove each time to prevent the gradual build up of deposits.

Small, hot fires are more efficient than large slumbering fires. Most of the energy in burning wood is released as a bright flame. The turbulence in the flames creates good mixing between the combustion air and the gases that are released from the wood as it heats up. The heat of the fire ignites and burns these gases. In contrast, the dense smoke from a slow, smouldering fire is potential heat energy that escapes up the chimney and either clings to the chimney flue as creosote or pollutes the outdoor air. Therefore, to gain the most heat from each load of firewood, the wood should be flaming throughout the burn cycle until it is reduced to ash.

If you do a fair bit of slow wood burning, it is good practice to burn a good, hot stove at regular intervals to keep your chimney dry and prevent the build up of tar.

When refuelling, place wood towards the back of the stove where it will burn hotter and more efficiently. Try to place logs length ways so that any spitting from the end grain does not go onto the glass window. The fuel should not be stacked higher than the top of the back fire brick. Once the stove is hot and running steady, it should be possible to maintain the nominal output by refuelling approximately once an hour.

Notes on wood burning

Wood burns most efficiently when the air for combustion is supplied from above the fire bed rather than below. The air supplied above the fire bed provides the oxygen necessary for the volatile gases (smoke), given off by the wood as it heats, to combust. This ensures that the gases are burnt and used to heat the appliance instead of being wasted up the chimney or condensing and forming tarry deposits inside the stove, the flue pipe or on the door glass.

Running the stove with only the bottom air control open will provide oxygen for the wood to burn on the fire base but will not provide air for the volatile gases above the fire bed to combust, resulting in a smoky inefficient fire. With the above in mind the stove should be run with the bottom air control closed and the top air control open.

Slow burning

To slow the burning rate and output from the stove reduce the air entering the stove via the air controls. The fire must be well established and the stove hot before a minimum combustion rate is attempted. Note that if the air supply is restricted too much the fire will burn dirty and inefficiently. Slow overnight burning is not advised.

Ventilation

The stove requires an adequate air supply for successful operation (see Installation section of these instructions for more details). Ensure that air bricks or grilles supplied for this purpose are not blocked. Be aware that the operation of exhaust fans or other appliances that compete for ventilation in the vicinity may affect the performance of the stove.

Running temperature

To get the best results from your stove it is recommended that a wood stove thermometer be fitted to the flue pipe just above the stove. Most thermometers are magnetic and if attached to the single wall flue pipe just above your stove will give a good indication of the flue gas temperatures.

150°C - 300°C

The flue gases should be in this temperature band for the safest, most efficient and most economical operation of your stove.

Below 150°C

This is below the condensation point of wood gases and may cause the build up of tar in the chimney, dirty the stove glass and result in the inefficient burning of fuel.

Above 300°C

Too hot. Heat will be wasted up the chimney. Excess heat may damage the stove or ignite an existing accumulation of tar resulting in a chimney fire.

Over heating

If the stove is allowed to get too hot and is over heating, close both of the air controls fully using the tool, keep the fire door closed and let the fire burn down.

Chimney Fire

In the event of a chimney fire dial 999 and ask for the Fire Service. Fully close the air controls on the stove and keep the fire door shut. Move any combustibles away from the stove and the chimney breast. Also check other rooms that the chimney passes through and move furniture and other combustibles away from the chimney here too.

Before using the stove again after a chimney fire have the chimney cleaned and inspected by a qualified person.

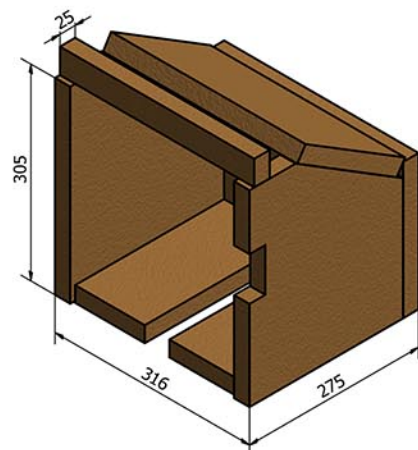
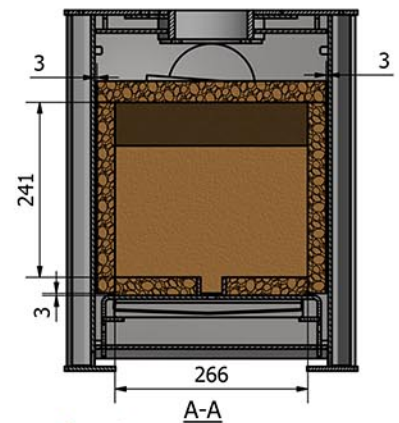

FIREBRICK INNER

Cleaning the glass

We recommend wiping the glass after a fire to prevent the build up of deposits. This is best done using a papertowel or a piece of newspaper.

Types of fuel

Wood needs to be well seasoned before it is burnt. Different woods take varying amounts of time to season but, as a general guide, before being used in a stove, wood should be cut to length, split and then stacked under cover (with the sides open to the air) for at least a year. Wood is ready for burning when radial cracks appear in the end of the logs and the water content is no higher than 20%. It is then good practice to have it in the log basket, inside the house, for a few days before it is actually used in the stove. The internal width of the firebox is 350mm and so firewood should be no longer than this.

The table at the back of these instruction outlines the characteristics for different types of wood.

Do not burn unseasoned wood in your wood burner. Do not burn particle board, lacquered, painted or treated wood, plastics, rubber or liquid fuels. The stove is suitable for burning solid fuel ie. briquettes I coal/ smokeless fuel when fitted with the multi fuel kit. The stove should not be used as an incinerator.

Ashes

The ashes should only be removed when the fire is out and has been left to cool completely. The wood bar can be removed to make access easier (figure 3). Wood burns well in it's own ash and so a thin layer of ash can be left in the bottom of the stove, this also helps to protect the base fire bricks.

Note: The above notes on operating your stove should be taken as guidelines only. Each stove installation is unique and the operation of each stove is subject to many variables Including; the fuel used, the size of the room, chimney performance, ventilation. As such, the best operation of your stove will be learned through experience only.

Maintenance & Cleaning

Any maintenance of the stove should only be carried out when it is cold. Daily maintenance is limited to vacuum cleaning the stove externally, or brushing down with a soft brush. Never use spirits to clean the stove, as this will remove the paint. Regularly check the flue exit from the stove to make sure there is no build up of deposits that will restrict the exit of the flue gasses.

Note: The stove must not be modified by an unauthorised person and any replacement parts should be as recommended by the manufacturer.

Chimney sweeping

The chimney should be swept a minimum once a year. If the stove is used regularly then the chimney should be swept more often. Your stove should be given a preventive inspection every time the chimney is swept to check the door rope seal, door handle, fire bricks and baffle and to remove any build up of soot and ashes.

Fire bricks

The fire brick insulation of the combustion chamber may, in time, become worn and damaged. Cracks in the insulation have no effect on the efficiency of the stove. The insulation only needs to be replaced if it has deteriorated to an extent that the insulation is no longer protecting the steel of the stove from flames.

Glass

If the glass is blackened with soot, it can easily be cleaned using one of the many specialist stove glass cleaning products available from stove shops.

Surface

The high temperature paint finish normally requires no treatment. Any damage or wear to small areas of the paint finish may be remedied using STOVEBRIGHT's high temperature aerosol paint (colour'charcoal: available from stove shops and from Firebelly). Make sure the stove is cold and read the instructions on the can carefully before applying the paint.

Installation

Building regulations

Installation of the Firebelly wood burning stove must comply with all local building regulations, including those referring to national and European standards. It is a good idea to consult your local chimney sweep to check the suitability of the chimney and ensure there is adequate updraft and suggest any remedies to potential chimney problems. Document J of the Building Regulations contains further information regarding the installation of solid fuel appliances and can be viewed here : www.odpm.gov.uk or follow the link on the Firebelly website.

Ventilation

There must be a constant supply of fresh air to the room in which the stove is to be installed. Fixed ventilation must be provided when installing any solid fuel stove which has an output higher than 5kws. For each kilowatt above five, 550 sq mm (2.56 sq ins) of ventilation is required. This stove has a nominal output of 4.8kws and therefore does not require an air brick. If other appliances requiring ventilation operate in the vicinity of the stove then there must be adequate ventilation to provide for both appliances operating simultaneously. NOTE Extractor fans when operating in the same room or space as the stove, may cause problems.

Load-bearing capacity of the floor

Before installing the stove, you must ensure that the load-bearing capacity of the floor can withstand the weight of the stove and any flue pipe and connections. The weight of the stove is **50KG**

Hearth

The stove should always be installed on a non-combustible hearth. The hearth should extend to a distance of 225mm in front of the stove and 150 mm to each side measured from the door of the combustion chamber. See document J of the building regulations for more information on hearth requirements.

Clearances

The minimum distance to combustible materials should be 150mm at the back of the stove and 100mm to the sides of the stove. Adjacent walls should be of suitable non-combustible construction, preferably brickwork. Make sure that there is a gap between an uninsulated flue pipe and any combustible material. This gap must be at least 3 x the outside diameter of the flue pipe (375mm for 5" single wall flue pipe), or 1.5 x the flue diameter (375mm for 5" single wall flue pipe) to non combustible surface. A minimum clearance of 80mm around the sides and back of the stove is recommended to allow for air movement and heat from the stove to enter the room.

Chimney requirements

An existing chimney or a new flue or chimney installation should be given a visual inspection to check that it is in good order, clear of obstructions and is of a suitable size and type for the stove. It may be necessary to sweep the flue (which should always be done anyway before fitting a stove or lining a chimney) and also, if necessary, to do a smoke test to check for gas tightness and chimney draft. The chimney or flue must not serve any other appliance.

For nominal heat output:

The minimum flue draught required is 12PA.
The mean flue gas temperature, anthracite 267 deg C.
The mean flue gas temperature, wood 231 deg C.

Air damper

It is recommended that chimneys with a strong updraft be fitted with a flue pipe damper or draft stabiliser so that the chimney draught can be regulated. It is not allowed that any damper close the pipe totally. There must always be a free area of min. 20% of the total opening of the chimney or the pipe.

Flue connection

The stoves has both rear and top flue connection. The flue blanking plate should be positioned over which ever outlet is not being used, position the blanking plate over the outlet and use the access via the the opposite flue outlet to fix the clamp to the back of it, see **Figure 4**. Position the stove and seal the flue connections with fire cement or a high temperature rope seal. **Figure 5** shows a typical installation for which you would need:

A register plate. - This is the plate used to seal off the throat of the fireplace and has a hole for the flue pipe, access for sweeping and, if required, a bracket to support the flue pipe.
The 5" flue pipe needed to go from the stove to the register plate .

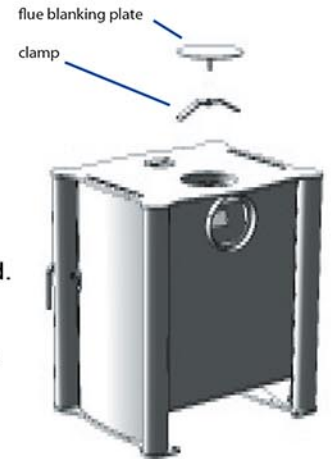

Figure 4

Operational problems

Blackened glass

- The wood is too damp. Only use wood stored for at least 12 months under cover and with a moisture level not exceeding 20% RH.
- Insufficient intake of air from the top air control. Open the top air control further. The air shield system is more efficient the more air is allowed to run over the glass panel.
- The stove is run at too low a temperature.

Smoke in the room when opening door

- Never open the door when there are high flames on the wood.
- Poor chimney performance - consult chimney sweep.
- Check the position of any fitted flue damper or stabiliser and make sure it is in the open position.

Uncontrollable combustion

- Damaged door seal. Fit new seal.
- If there is an excessive chimney draft - fit a draft stabiliser in the flue pipe - consult a chimney sweep.

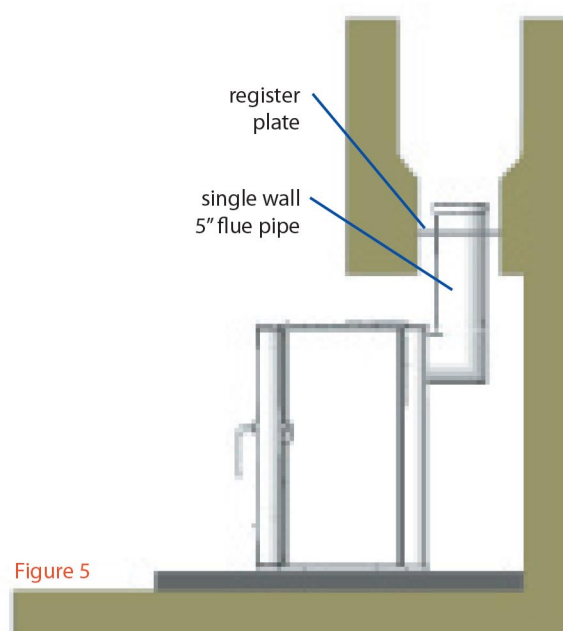

Firebelly Stove Maintenance

It is important to look after and maintain your Firebelly to enable you to enjoy the full benefits the stove offers.

- When cleaning the exterior of your Firebelly, please do not use any wet, damp or abrasive cloths. Never use any chemicals, detergents or polish. The stove is extremely easy to clean and only required a dry, soft cloth when the stove is cold.
- Be sure to never place anything on top of the stove as the heat will melt the object to the unit.
- This stove reaches high temperatures, please do not touch any part of the stove whilst it is operating or still hot.
- When loading the stove with fuel, be sure to place the logs inside the firebox. The stove is lined with a delicate material and any knocks or bangs can reduce the lifespan.
- We recommend using high quality, dry or well-seasoned wood to get the best performance from the stove and prolong the lifespan of the firebox linings.
- Due to the unique AirShield Technology, the glass should always stay clean. However, burning damp or poor quality wood and materials other than wood will cause the glass to blacken. If this occurs, simply wipe clean with scrunched up newspaper.
- The Firebelly is installed with a ropeseal around the glass and flue pipe. Please do not remove or adjust this seal.
- We recommend to have the flue swept and inspected at least every 12 months



Common Name	Botanical Name	Comments	Grade
Alder	Alnus	A low quality firewood	Grade: 1
Apple	Malus	Needs to be seasoned well. Burns well with a pleasant smell and without sparking/spitting.	Grade: 3
Ash	Fraxinus	low water content (approx. 50%) and can be split very easily with an axe. It can be burned green but like all wood is best	Grade: 4
Beech	Fagus	Beech has a high water content (approx. 90%) so only burns well when seasoned well. Not as good as Oak.	Grade: 3
Birch	Betula	Birch is an excellent firewood and will burn unseasoned. However, it does burn very fast so is best mixed with slower	Grade: 3-4
Cedar	Cedrus	off a good, lasting heat. Doesn't spit too much and small pieces can be burned unseasoned	Grade: 2
Cherry	Prunus	Needs to be seasoned well. Burns well with a pleasant smell and without spitting.	Grade: 2-3
Elm	Ulmus	A good firewood but due to its high water content of approximately 140% (more water than wood!) it must be seasoned very well. It may need assistance from another faster burning wood such as Birch to keep it burning well. However it gives off a good, lasting heat and burns very slowly. Dutch Elm Disease is producing a constant & plentiful supply of small dead hedgerow Elm trees of a small diameter. Larger pieces of wood will prove difficult to split.	Grade: 2-3
Eucalyptus	Eucalyptus	Allow to season well since the wood is very wet (sappy) when fresh. Can be difficult to split due to stringy wood fibre. Best method is to slice into rings and allow to season during the summer, the rings will start to split themselves. Burns fast with a pleasant smell and without spitting.	Grade: 2-3
Hawthorn	Crataegus	Good firewood. Burns well	Grade: 3-4
Hazel	Corylus	Excellent firewood. Allow to season. Burns fast but without spitting	Grade: 4
Holly	Ilex	Can be burnt green. A good firewood	Grade: 3
Hornbeam	Carpinus	Good firewood. Burns well	Grade: 3
Horse Chestnut	Aesculus	A low quality firewood	Grade: 2
Larch	Larix	Needs to be seasoned well. Spits excessively while it burns and forms an oily soot within chimney's.	Grade: 1
Lime	Tilia	A low quality firewood	Grade: 2
Oak	Quercus	One of the best firewood's. When seasoned well, it gives off a good, lasting heat. Burns reasonably slowly.	Grade: 4
Pear	Pyrus	Needs to be seasoned well. Burns well with a pleasant smell and without spitting.	Grade: 3
Pine	Pinus	Needs to be seasoned well. Spits while it burns and forms an oily soot within chimney's.	Grade: 1
Plane	Platanus	A usable firewood	Grade: 3
Poplar	Populus	Considered a poorer firewood (see comments below)	Grade: 1
Rowan	Sorbus aucuparia	Good firewood. Burns well	Grade: 3
Spruce	Picea	A low quality firewood	Grade: 2



Firebelly Stoves Ltd, Unit B Marshall Hall Mills, Elland, West Yorkshire, HX5 9DU.

BSEN 13240: 2001 + Amd 2:2004

Room Heater Fired By Solid Fuel

FB Eco

SERIAL NUMBER		
MINIMUM DISTANCE TO COMBUSTIBLE MATERIALS		SIDE 100mm REAR 150mm
EMISSION OF CO (13% O₂)		0.21
FLUE GAS TEMPERATURE	Wood Anthracite	Degrees Celsius 231 Degrees Celsius 267
THERMAL OUTPUT (NOMINAL)		4.8kw
ENERGY EFFICIENCY	Wood Anthracite	77.2% 67.8%

Read and follow the operating instructions

Intermittent Use Only

Not to be used with a shared flue

FB Eco Name Plate

Model FB Eco

Follow the users instruction

Nominal Heat Output 4.8KW

Minimum distances from combustable materials Side: 100mm
Rear: 150mm



Co Concentration at (13% O₂) 0.21%

Not to be used with a shared flue

Efficiency %
Wood 77.2
Anthracite 67.8

Use only recommended fuels

Tested To EN13240

Intermittent use only





Instructions for fitting of Multi Fuel rack

1. Remove ash pan and all lining from inside of the stove, also removing the slotted base plate along with the 2 bricks covering it.
2. Replace this with the multi fuel rack in base of the stove.
3. Insert back board resting on rear edge of multi fuel rack behind round bars.
4. Rest long edge of rear top baffle on edge of back board.
5. Lifting the front edge of the top baffle, insert each side brick with the highest point to front of the stove. These should sit on top of the rack between the round bars and the stove sides.
6. Rest top baffle down onto the top edges of the side pieces.
7. Line the rack with 5 removable round bars.
8. If using woodburning base plate, ensure back board is resting on the rear edge, repeating steps 2-5 then inserting the base bricks to complete.