

## Salt & Pepper Mill Kits Assembly Instructions

### Kit Features

- Ceramic Components
- Adjustable Grind
- Can be made in 3 different sizes: 6", 9", or 12"

### Required Accessories

- 1-1/2" Forstner Bit
- 1-1/16" Forstner Bit
- 9" Forstner Bit Extension
- 3 Jaw Drill Chuck
- 60° Live Center
- 1" Jam Chuck
- 7mm Drill Bit
- Sanding and finishing supplies

### Required Blanks (see Diagram B)

- Base Blank: 2-1/2" Min Square x 4 3/8", 7 1/2", or 10 1/2" (adjust to fit)

Be sure that both surfaces are cut to 90°

- Head Blank: 2-1/2" Min Square x 2-1/16" Long

Diagram A - Parts

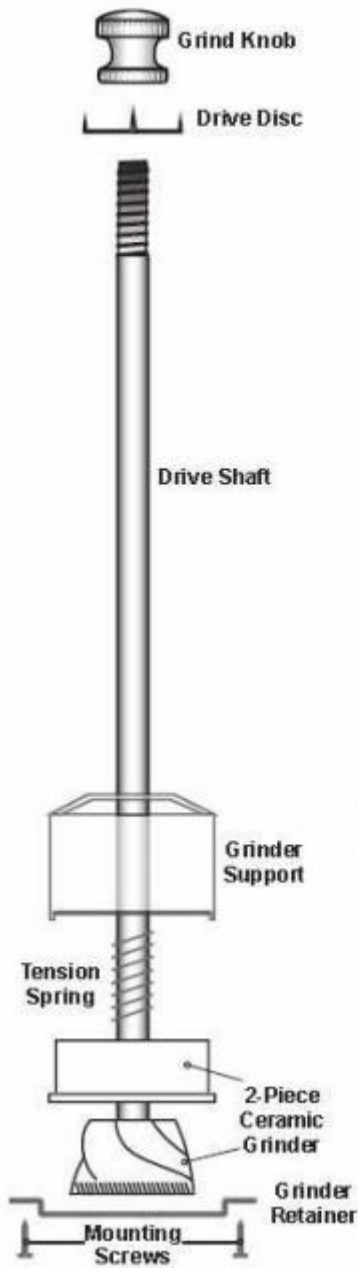
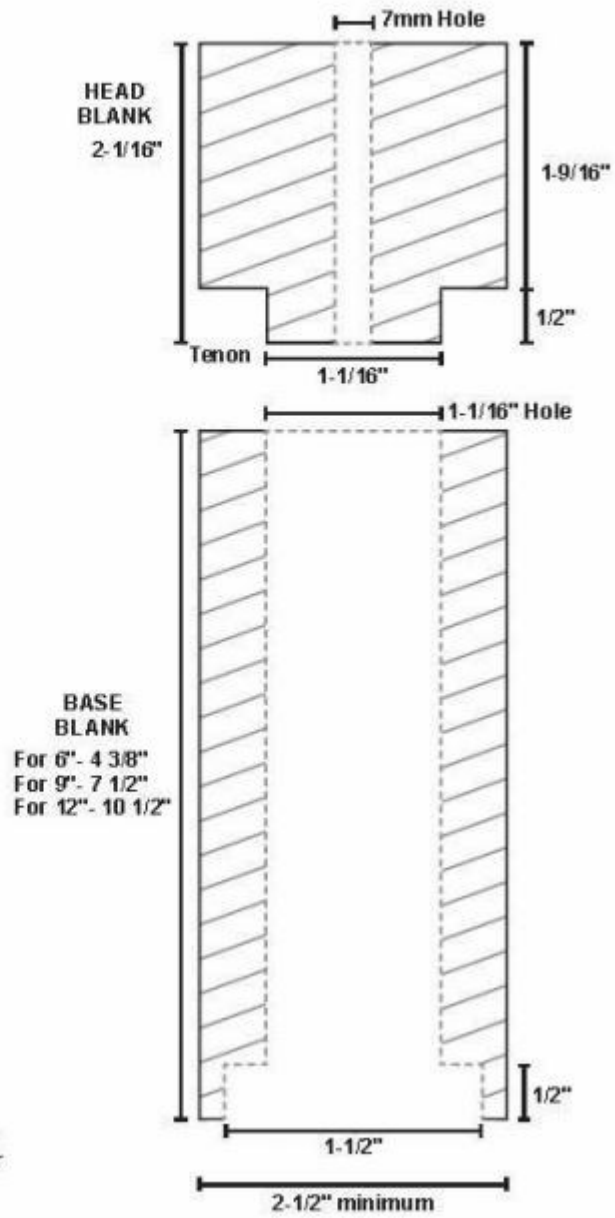

Diagram B  
Blank Dimensions



### Prepare Mill Head Blank:

1. Mark the center of your mill head blank on both ends.
2. Place mill head blank into lathe chuck and turn a 1-1/16" dia. by 1/2" long tenon on one end of blank.
3. Remove from lathe chuck and drill a 7mm dia. hole through the center of the mill head blank.

### Prepare Mill Base Blank:

1. Mark the center of your base blank on both ends. drill a 1-1/2" diameter hole 1/2" deep. This will be the bottom of the mill.
2. With a 1-1/16" drill bit, drill a hole using the previous hole as your center guide. It is recommended that you drill from both ends of the blank for better results and less wear and tear.

### Turning the pepper mill

Place the tenon of the mill head blank into the 1-1/16" hole of the mill base blank. Set up as shown in Diagram C turning both ends at once. Insert the tenon into the opening at the upper end of the base blank. Mount the 3 jaw drill chuck into the head stock of the lathe. Insert the jam chuck and lock into the jaws. Mount the wood assembly, recessed end in first over the jam chuck. Bring the tail stock forward with the center into the hole. Lock in place. Use a wrench to tighten the nut to expand the jam chuck in the hole. Tighten to make sure that it is safe to turn.

Caution: Please note that the tenon of the head blank must fit the base blank hole without any play. A loose fit may cause the final mill to be off center or vibrate when turning produce an undesirable result or possible injury. Turn the wooden blanks to your desired shape or profile of choice. Sand and finish the wood. Be sure to use a food safe finish or polish.

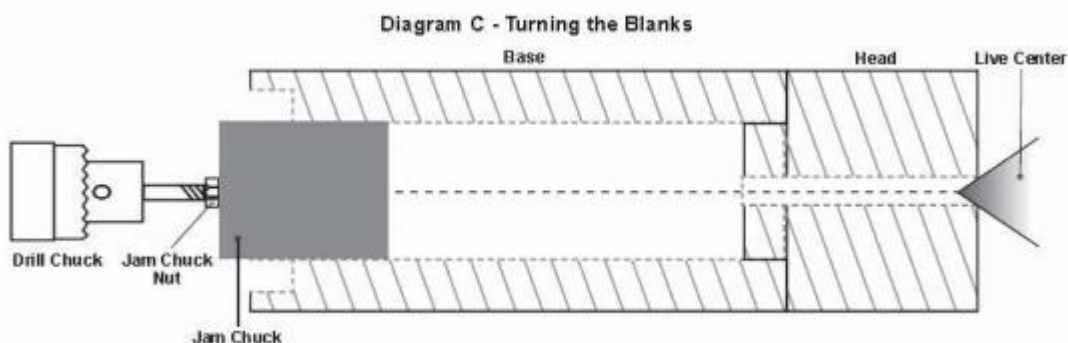

## Assembly

(Line up finished parts according to Diagram D)

1. Mount the drive disc on the head.
2. Insert the grinder support in the bottom of the base.
3. Place the drive shaft with the grinder housing and grinder up through the base.
4. Secure the grinder retainer and 2 mounting screws.
5. Loosen the grinder knob for a coarser grind.

Diagram D - Assembly

