

Seam Ripper & Stiletto Kit

#PKSR1 Single Blade (small Style A)

#PKSR2 Double Blade (large & small Style B)

#PKSRNXX Necklace (Style C)

#PKSR3 Stiletto (Style A)

Kit Features

- Style A - Single Blade, small ripper with clip. Reverses into handle for safety.
- Style B - Double Blade, small & large rippers.
- Style C single small blade w/ magnetic necklace chain catch.
- Sharp blade reverses into handle for safety.
- 8mm tubes

Required Accessories

- 7mm, Pen Mandrel
- 8mm Drill Bit #PKPARK-8MM
- 8mm Barrel Trimmer (use from #PKTRIMKIT)
- 3 pc. Bushings Set #PKSRBU (use 2 of the 3 in the set for each style)
- 2 part glue, epoxy or Insta-cure (cyanoacrylate).

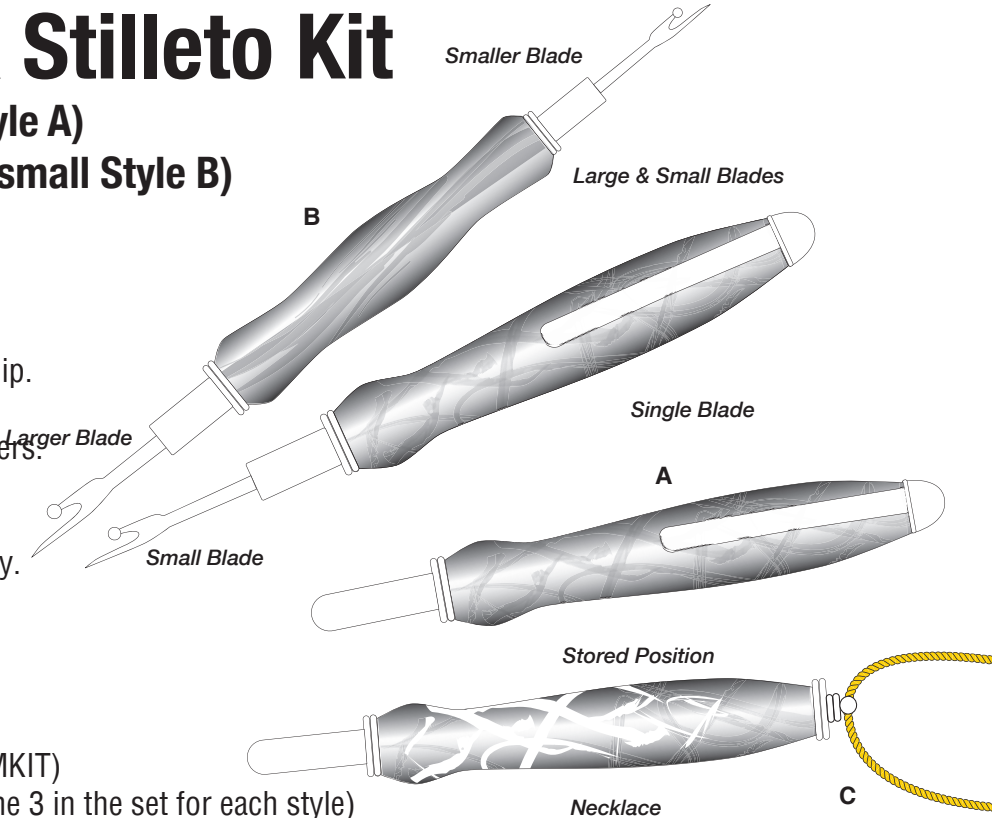
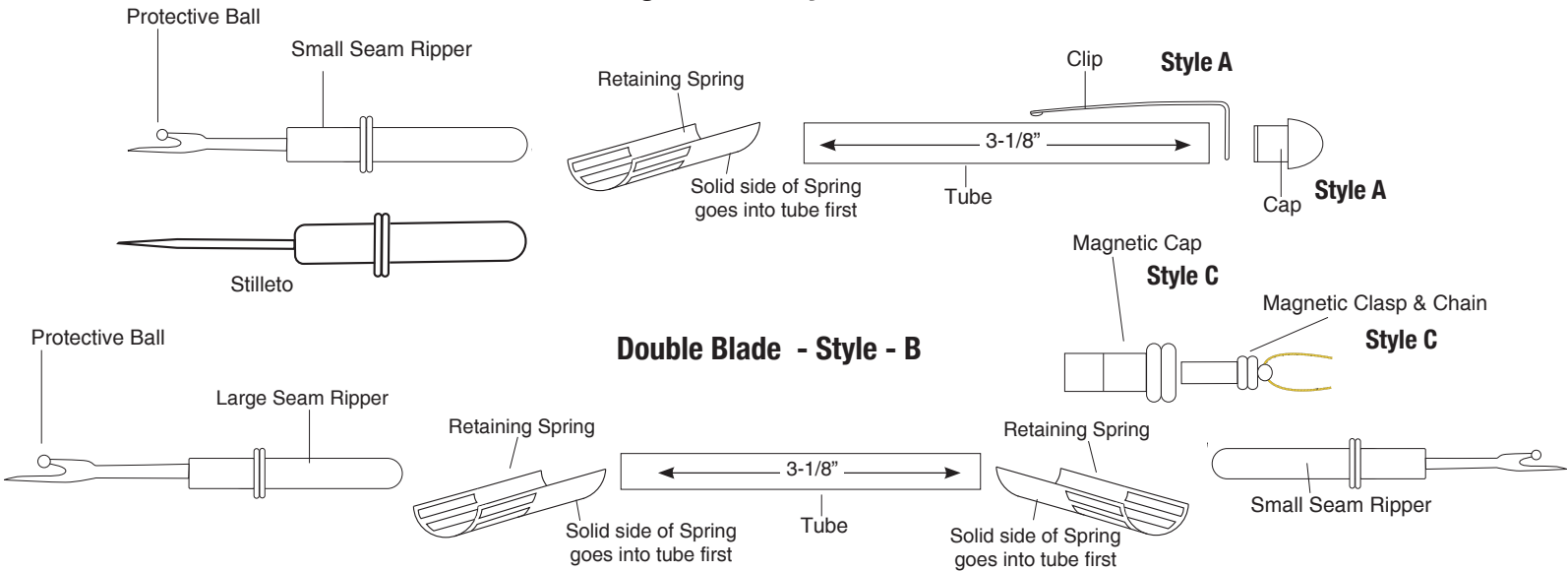

Diagram A - Parts List

Single Blade - Style - A & C



Preparing the Blank

- Prepare and cut a blank of 3/4" or larger, to the length of the brass tube (add 1/16" for trimming)
- Drill a 8mm hole through the center of the blank.
- Spread glue over the tube, insert into blank with a twisting motion to spread the glue evenly inside.
- Center the tube inside the blank.
- When glue is dry. Trim the ends of the blank flush to the tube.

Diagram B - Turning the Blank

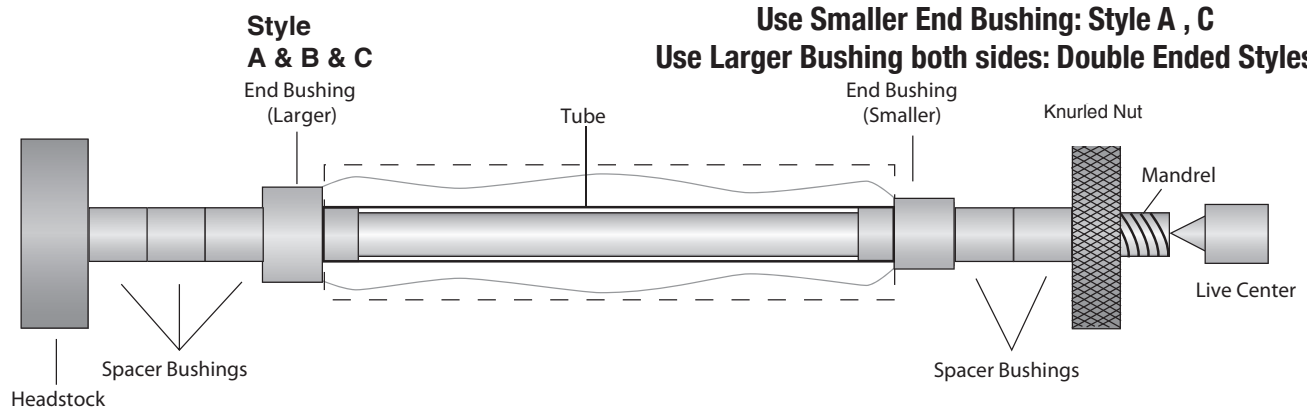

Turning the Blank

- Place the bushings and blank on the mandrel according to Diagram B.
- Use the larger end bushing on style A and a smaller bushing on the other end. For style B & C use the larger bushing on both ends.
- Thread on the knurled nut and hand tighten to hold all items in place.
- Slide the tailstock to the mandrel shaft, (do not overtighten, it could damage the mandrel) lock in place.
- Turn the handle ends down, flush with the bushings using the lathe tools, gradually increasing the grades of sand paper.
- Finish the wood with friction polish or use any PSI project finish of your choice.

Assembly

For Single style A & C:

- Place the clip over the extension of the cap. Press this assembly into the upper end of the handle with smaller diameter.
- Or (for necklace Style C) Press the magnetic cap, narrow end in first into the upper end of the barrel.

For Styles A, B & C:

- Squeeze the retaining spring to a small round circle (DO NOT CREASE) and insert (solid side first) into opening at the end(s). Keep the spring curled until it is 2/3 to 3/4 of the way inside the tube. Push in, flush to the surface.
- Slide the seam ripper assembly in and out with both ends to assure a secure fit.
- If spring does not hold in properly (i.e. the spring slides into the tube), Take a Q-tip and dip into CA glue insert the spring and allow the CA to dry. The spring should now operate properly.
- When not in use, reverse the ripper assembly to safely store the blade(s). If the ripper assembly is held by the spring when the ripper is out, but does not stay when the ripper is being stored inside, then you ignored the multiple times this instruction said to insert the solid side of the spring first.
- Insert the chain through the small ring on the magnetic bar, lock the clasp.
- Insert the bar into the magnetic cap.

Diagram E - Bushing #PKSRBU

