

8" Benchtop Drill Press



Operator's Manual

Record the serial number and date of purchase in your manual for future reference.

Serial Number: _____ Date of purchase: _____

For technical support or parts questions, email techsupport@rikontools.com or call toll free at (877)884-5167

TABLE OF CONTENTS

Specifications.....	2
Safety Instructions	3 - 6
Getting To Know Your Machine	7
Contents of Package	7 - 8
Installation	8
Assembly	9 - 10
Adjustments.....	11 - 12
Maintenance	13
Electricals & Wiring Diagram	5 & 13
Troubleshooting	14
Parts Diagrams & Parts Lists	15 - 18
Notes	19
Warranty	19

SPECIFICATIONS

Motor	1/3 HP
Motor Speed (no load).....	1,720 RPM
Volts	120 V
Amps, Hertz	2.5 A, 60 Hz
Swing	8"
Chuck Size	1/2"
Chuck Taper	JT33
Drilling Capacity	1/2"
Spindle Travel	2"
Spindle Taper	JT33
Speeds	5
Speed Range (RPM).....	620, 1100, 1720, 2340, 3100
Quill Diameter	1-1/2"
Table Size	6-5/8" x 6-3/8"
Table Tilts	45°
Table Rotates	360°
Maximum Chuck to Table	7-1/16"
Maximum Chuck to Base	10-1/4"
Column Diameter	1-7/8"
Height	22-3/4"
Base Size	11" x 7-1/8"
Net Weight	32 lbs.

NOTE: The specifications, photographs, drawings and information in this manual represent the current model when the manual was prepared. Changes and improvements may be made at any time, with no obligation on the part of Rikon Power Tools, Inc. to modify previously delivered units. Reasonable care has been taken to ensure that the information in this manual is correct, to provide you with the guidelines for the proper safety, assembly and operation of this machine.

SAFETY INSTRUCTIONS

IMPORTANT! Safety is the single most important consideration in the operation of this equipment. **The following instructions must be followed at all times.** Failure to follow all instructions listed below may result in electric shock, fire, and/or serious personal injury.

There are certain applications for which this tool was designed. We strongly recommend that this tool not be modified and/or used for any other application other than that for which it was designed. If you have any questions about its application, do not use the tool until you have contacted us and we have advised you.

SAFETY SYMBOLS



SAFETY ALERT SYMBOL: Indicates DANGER, WARNING, or CAUTION. This symbol may be used in conjunction with other symbols or pictographs.



Indicates an imminently hazardous situation, which, if not avoided, could result in death or serious injury.



Indicates a potentially hazardous situation, which, if not avoided, could result in death or serious injury.



Indicates a potentially hazardous situation, which, if not avoided, could result in minor or moderate injury.

NOTICE: Shown without Safety Alert Symbol indicates a situation that may result in property damage.

GENERAL SAFETY

KNOW YOUR POWER TOOL. Read the owner's manual carefully. Learn the tool's applications, work capabilities, and its specific potential hazards.

BEFORE USING YOUR MACHINE

To avoid serious injury and damage to the tool, read and follow all of the Safety and Operating Instructions before operating the machine.

1. Some dust created by using power tools contains chemicals known to the State of California to cause cancer, birth defects, or other reproductive harm.

Some examples of these chemicals are:

- Lead from lead-based paints.
- Crystalline silica from bricks, cement, and other masonry products.
- Arsenic and chromium from chemically treated lumber.

Your risk from these exposures varies, depending on how often you do this type of work. To reduce your exposure to these chemicals: work in a well ventilated area and work with approved safety equipment, such as those dust masks that are specially designed to filter out microscopic particles.

2. **READ** the entire Owner's Manual. **LEARN** how to use the tool for its intended applications.

3. **GROUND ALL TOOLS.** If the tool is supplied with a 3 prong plug, it must be plugged into a 3-contact electrical receptacle. The 3rd prong is used to ground the tool and provide protection against accidental electric shock. **DO NOT** remove the 3rd prong. See Grounding Instructions on the following pages.

4. **AVOID A DANGEROUS WORKING ENVIRONMENT.** **DO NOT** use electrical tools in a damp environment or expose them to rain.

5. **DO NOT** use electrical tools in the presence of flammable liquids or gases.

6. **ALWAYS** keep the work area clean, well lit, and organized. **DO NOT** work in an environment with floor surfaces that are slippery from debris, grease, and wax.

7. **KEEP VISITORS AND CHILDREN AWAY. DO NOT** permit people to be in the immediate work area, especially when the electrical tool is operating.

8. **DO NOT FORCE THE TOOL** to perform an operation for which it was not designed. It will do a safer and higher quality job by only performing operations for which the tool was intended.

9. **WEAR PROPER CLOTHING. DO NOT** wear loose clothing, gloves, neckties, or jewelry. These items can get caught in the machine during operations and pull the operator into the moving parts. The user must wear a protective cover on their hair, if the hair is long, to prevent it from contacting any moving parts.

10. **CHILDPROOF THE WORKSHOP AREA** by removing switch keys, unplugging tools from the electrical receptacles, and using padlocks.

11. **ALWAYS UNPLUG THE TOOL FROM THE ELECTRICAL RECEPTACLE** when making adjustments, changing parts or performing any maintenance.

SAFETY INSTRUCTIONS

12. KEEP PROTECTIVE GUARDS IN PLACE AND IN WORKING ORDER.

13. AVOID ACCIDENTAL STARTING. Make sure that the power switch is in the “OFF” position before plugging in the power cord to the electrical receptacle.

14. REMOVE ALL MAINTENANCE TOOLS from the immediate area prior to turning “ON” the machine.

15. USE ONLY RECOMMENDED ACCESSORIES. Use of incorrect or improper accessories could cause serious injury to the operator and cause damage to the tool. If in doubt, check the instruction manual that comes with that particular accessory.

16. NEVER LEAVE A RUNNING TOOL UNATTENDED. Turn the power switch to the “OFF” position. **DO NOT** leave the tool until it has come to a complete stop.

17. DO NOT STAND ON A TOOL. Serious injury could result if the tool tips over, or you accidentally contact the tool.

18. DO NOT store anything above or near the tool where anyone might try to stand on the tool to reach it.

19. MAINTAIN YOUR BALANCE. DO NOT extend yourself over the tool. Wear oil resistant rubber soled shoes. Keep floor clear of debris, grease, and wax.

20. MAINTAIN TOOLS WITH CARE. Always keep tools clean and in good working order. Keep all blades and tool bits sharp, dress grinding wheels and change other abrasive accessories when worn.

21. EACH AND EVERY TIME, CHECK FOR DAMAGED PARTS PRIOR TO USING THE TOOL. Carefully check all guards to see that they operate properly, are not damaged, and perform their intended functions. Check for alignment, binding or breaking of moving parts. A guard or other part that is damaged should be immediately repaired or replaced.

22. DO NOT OPERATE TOOL WHILE TIRED, OR UNDER THE INFLUENCE OF DRUGS, MEDICATION OR ALCOHOL.

23. SECURE ALL WORK. Use clamps or jigs to secure the work piece. This is safer than attempting to hold the work piece with your hands.

24. STAY ALERT, WATCH WHAT YOU ARE DOING, AND USE COMMON SENSE WHEN OPERATING A POWER TOOL.

A moment of inattention while operating power tools may result in serious personal injury.

25. ALWAYS WEAR A DUST MASK TO PREVENT INHALING DANGEROUS DUST OR AIRBORNE PARTICLES, including wood dust, crystalline silica dust and asbestos dust. Direct particles away from face and body. Always operate tool in well ventilated area and provide for proper dust removal. Use dust collection system wherever possible. Exposure to the dust may cause serious and permanent respiratory or other injury, including silicosis (a serious lung disease), cancer, and death. Avoid breathing the dust, and avoid prolonged contact with dust. Allowing dust to get into your mouth or eyes, or lay on your skin may promote absorption of harmful material. Always use properly fitting NIOSH/OSHA approved respiratory protection appropriate for the dust exposure, and wash exposed areas with soap and water.

26. USE A PROPER EXTENSION CORD IN GOOD CONDITION. When using an extension cord, be sure to use one heavy enough to carry the current your product will draw. The table on the following page shows the correct size to use depending on cord length and nameplate amperage rating. If in doubt, use the next heavier gauge. The smaller the gauge number, the larger diameter of the extension cord. If in doubt of the proper size of an extension cord, use a shorter and thicker cord. An undersized cord will cause a drop in line voltage resulting in a loss of power and overheating.

USE ONLY A 3-WIRE EXTENSION CORD THAT HAS A 3-PRONG GROUNDING PLUG AND A 3-POLE RECEPTACLE THAT ACCEPTS THE TOOL’S PLUG.

27. ADDITIONAL INFORMATION regarding the safe and proper operation of this product is available from:

- Power Tool Institute
1300 Summer Avenue
Cleveland, OH 44115-2851
www.powertoolinstitute.org
- National Safety Council
1121 Spring Lake Drive
Itasca, IL 60143-3201
www.nsc.org
- American National Standards Institute
25 West 43rd Street, 4th Floor
New York, NY 10036
www.ansi.org
- ANSI 01.1 Safety Requirements for Woodworking Machines and the U.S. Department of Labor regulations
www.osha.gov

28. SAVE THESE INSTRUCTIONS. Refer to them frequently and use them to instruct others.

SAFETY INSTRUCTIONS

ELECTRICAL SAFETY

⚠ WARNING: THIS TOOL MUST BE GROUNDED WHILE IN USE TO PROTECT THE OPERATOR FROM ELECTRIC SHOCK.

IN THE EVENT OF A MALFUNCTION OR BREAKDOWN, grounding provides the path of least resistance for electric current and reduces the risk of electric shock. This tool is equipped with an electric cord that has an equipment grounding conductor and requires a grounding plug (not included). The plug **MUST** be plugged into a matching electrical receptacle that is properly installed and grounded in accordance with **ALL** local codes and ordinances.

DO NOT MODIFY ANY PLUG. If it will not fit the electrical receptacle, have the proper electrical receptacle installed by a qualified electrician.

IMPROPER ELECTRICAL CONNECTION of the equipment grounding conductor can result in risk of electric shock. The conductor with the green insulation (with or without yellow stripes) is the equipment grounding conductor. **DO NOT** connect the equipment grounding conductor to a live terminal if repair or replacement of the electric cord or plug is necessary.

CHECK with a qualified electrician or service personnel if you do not completely understand the grounding instructions, or if you are not sure the tool is properly grounded when installing or replacing a plug.

USE ONLY A 3-WIRE EXTENSION CORD THAT HAS THE PROPER TYPE OF A 3-PRONG GROUNDING PLUG THAT MATCHES THE MACHINE'S 3-PRONG PLUG AND ALSO THE 3-POLE RECEPTACLE THAT ACCEPTS THE TOOL'S PLUG. *

REPLACE A DAMAGED OR WORN CORD IMMEDIATELY.

This tool is intended for use on a circuit that has an electrical receptacle as shown in **FIGURE A**. It shows a 3-wire electrical plug and electrical receptacle that has a grounding conductor. If a properly grounded electrical receptacle is not available, an adapter as shown in **FIGURE B** can be used to temporarily connect this plug to a 2-contact ungrounded receptacle. The adapter has a rigid lug extending from it that **MUST** be connected to a permanent earth ground, such as a properly grounded receptacle box. **THIS ADAPTER IS PROHIBITED IN CANADA.**

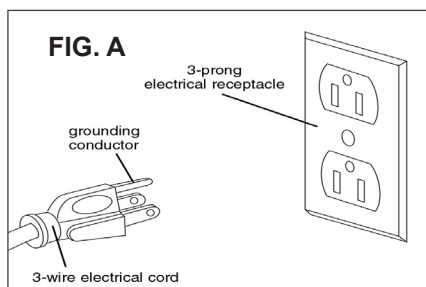

EXTENSION CORDS

⚠ WARNING: THE USE OF AN EXTENSION CORD WITH THIS MACHINE IS NOT RECOMMENDED. For best power and safety, plug the machine directly into a dedicated, grounded electrical outlet that is within the supplied cord length of the machine.

If an extension cord needs to be used, it should only be for a limited operation of the machine. The extension cord should be as short as possible in length, and have a minimum gauge size of 14AWG.

⚠ WARNING: Check extension cords before each use. If damaged replace immediately. Never use a tool with a damaged cord, since touching the damaged area could cause electrical shock, resulting in serious injury.

Use a proper extension cord. Only use cords listed by Underwriters Laboratories (UL). Other extension cords can cause a drop in line voltage, resulting in a loss of power and overheating of tool. When operating a power tool outdoors, use an outdoor extension cord marked "W-A" or "W". These cords are rated for outdoor use and reduce the risk of electric shock.

MINIMUM RECOMMENDED GAUGE FOR EXTENSION CORDS (AWG)

120 VOLT OPERATION ONLY				
	25' LONG	50' LONG	100' LONG	150' LONG
0 to 6 Amps	18 AWG	16 AWG	16 AWG	14 AWG
6 to 10 Amps	18 AWG	16 AWG	14 AWG	12 AWG
10 to 12 Amps	16 AWG	16 AWG	14 AWG	12 AWG

⚠ WARNING: Keep the extension cord clear of the working area. Position the cord so that it will not get caught on lumber, tools or other obstructions while you are working with your power tool.

* Canadian electrical codes require extension cords to be certified SJT type or better.

** The use of an adapter in Canada is not acceptable.

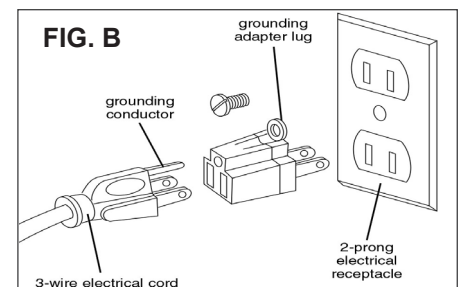

SAFETY INSTRUCTIONS

SPECIFIC SAFETY INSTRUCTIONS FOR DRILL PRESSES

This machine is intended for the drilling of solid woods, composites, plastics and metals. The permissible workpiece dimensions must be observed (see Technical Specification). Any other use not as specified, including modification of the machine or use of parts not tested and approved by the equipment manufacturer can cause unforeseen damage and invalidate the warranty.

ATTENTION: Use of this machine still presents risks that cannot be eliminated by the manufacturer. Therefore, the user must be aware that wood working machines are dangerous if not used with care and all safety precautions are adhered to.

1. Do Not operate the Drill Press until it is assembled and you have read the instructions.
2. Do not operate the Drill Press unless you are familiar with its safe operation. If you are not familiar with the operation of a Drill Press, seek advice from a qualified individual.
3. If you are using a bench top Drill Press, it must be securely fastened to a stand or bench.
4. If you are operating a floor Drill Press it must be securely fastened to the floor.
5. Always clear the table and work area before turning on the Drill Press.
6. Always use drill bits, cutting tools and accessories with a 1/2" shank or less.
7. Never place hands near the drill bit, cutting tool or accessory.
8. Never wear loose clothing, gloves or ties while operating the Drill Press. Tie loose hair back.
9. Always have a firm footing while operating the Drill Press.
10. Always keep work surface and work areas clear of debris.
11. Never attempt to do set-up work, assembly or layout work on the Drill Press while it is in operation.
12. Never start the Drill Press with the drill bit, cutting tool or accessory in contact with the workpiece.
13. Always lock all table, column and head locks before turning on the Drill Press.
14. Never operate the Drill Press with a damaged drill bit, cutting tool or accessory.
15. Always check the drill bit, cutting tool or accessory is tight in the chuck.
16. Never operate the Drill Press with the chuck key in the chuck.
17. Always adjust the depth stop to avoid drilling into the table surface.
18. Never drill material unless it is properly supported. Non flat work-pieces require additional support.
19. Always clamp the work piece to the table.
20. Always support large work-pieces at the same height as the table.
21. Never remove the work-piece or clear the table until the Drill Press comes to a complete stop.
22. Always wear a face shield and safety glasses while operating the Drill Press.
23. Never operate the Drill Press with missing, damaged, worn, loose or defective parts.
24. Never adjust, change speeds or perform maintenance on the Drill Press while it is operating.
25. Always clean the work surface and work area when finished operating the Drill Press.
26. Always disconnect the power when adjusting or performing maintenance on the Drill Press.
27. Always disconnect the power when finished using the Drill Press to prevent accidental operation.

This owner's manual is not a teaching aid and is intended to show assembly, adjustments, and general use.

California Proposition 65 Warning

 **WARNING:** Drilling, sawing, sanding or machining wood products can expose you to wood dust, a substance known to the State of California to cause cancer. Avoid inhaling wood dust or use a dust mask or other safeguards for personal protection.

For more information go to www.P65Warnings.ca.gov/wood.

GETTING TO KNOW YOUR MACHINE

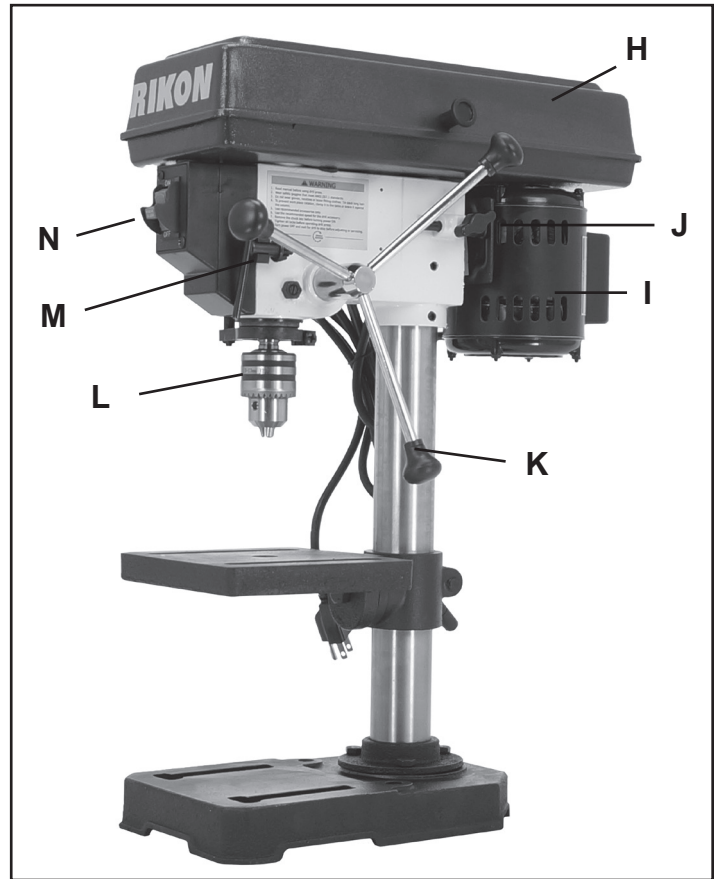
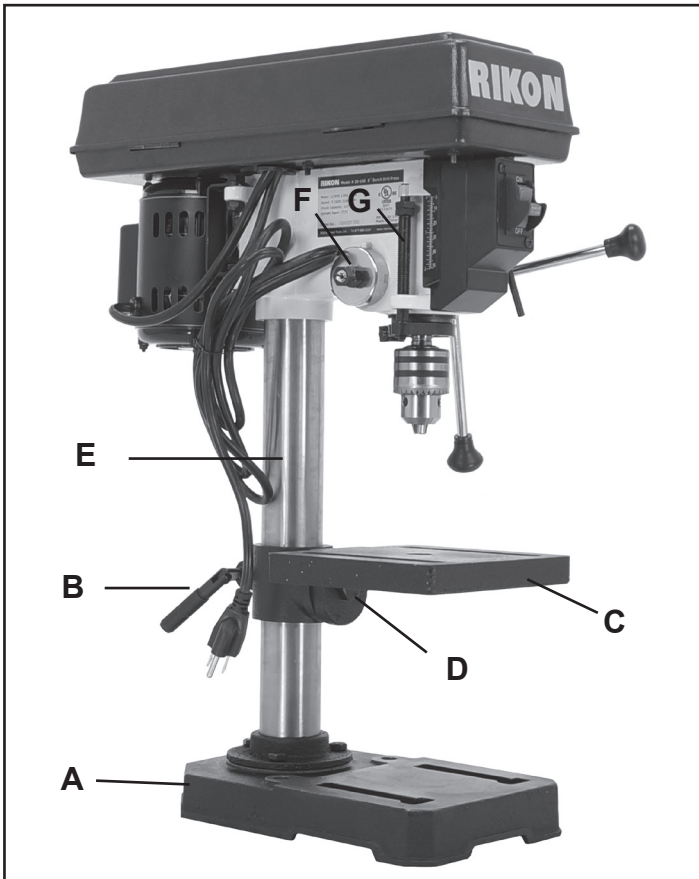

- A. Base
- B. Table Lock Handle
- C. Table
- D. Table Tilt Locking Screw
- E. Column Support Tube
- F. Handle Return Spring
- G. Depth Stop

- H. Belt Cover
- I. Motor
- J. Motor/Belt Adjusting Knob
- K. Feed Handles
- L. Chuck
- M. Chuck Key Holder
- N. On/Off Safety Switch

CONTENTS OF PACKAGE

Unpacking and Clean-up

1. Carefully remove all contents from the shipping carton. Compare the contents with the list of contents to make sure that all of the items are accounted for, before discarding any packing material. Place parts on a protected surface for easy identification and assembly. If any parts are missing or broken, please call RIKON Customer Service (877-884-5167) as soon as possible for replacements. DO NOT turn your machine ON if any of these items are missing. You may cause injury to yourself or damage to the machine.
2. Report any shipping damage to your local distributor. Take photo for any possible insurance claims.
3. Clean all rust protected surfaces with ordinary house hold type grease or spot remover. Do not use; gasoline, paint thinner, mineral spirits, etc. These may damage painted surfaces.
4. Apply a coat of paste wax to the table to prevent rust. Wipe all parts thoroughly with a clean dry cloth.
5. Set packing material and shipping carton aside. Do not discard until the machine has been set up and is running properly.

CONTENTS OF PACKAGE

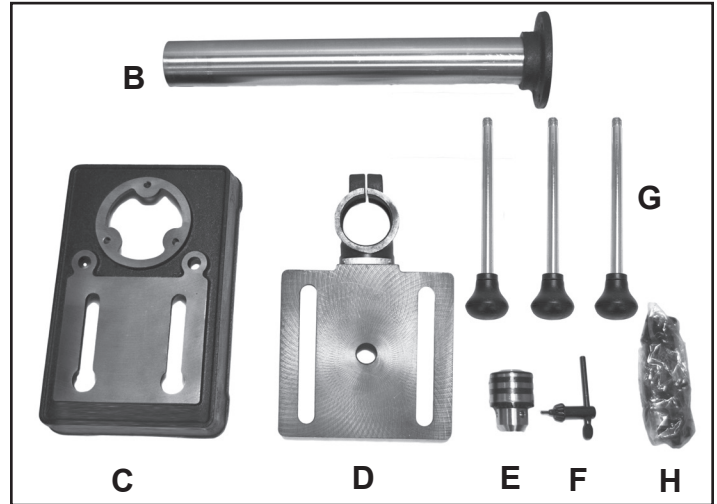
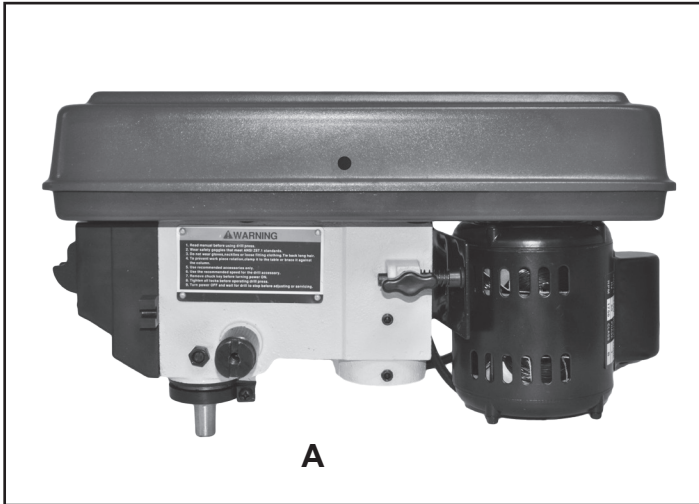

LIST OF LOOSE PARTS

- A. Drill Press Head Assembly
- B. Column
- C. Base
- D. Table
- E. 1/2" Chuck
- F. Chuck Key
- G. Feed Handles (3)
- H. Hardware Bag (See Contents Below)
 - I. Table Lock Handle
 - J. Column Mounting Bolts (3)
 - K. 3 & 4mm Hex Wrenches
 - L. Knob & Screw for Belt Cover

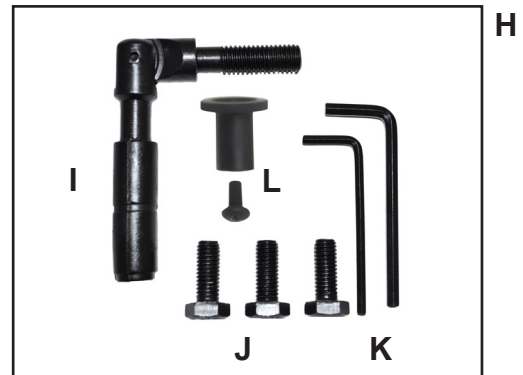

- M. Owner's Manual (not shown)

INSTALLATION

MOVING & INSTALLING THE DRILL PRESS

1. When moving the Drill Press, hold both the column and under the drill press base to lift and move the machine. **CAUTION:** The drill press head with attached motor is top heavy and must remain upright to avoid tipping.
2. Secure the machine onto a solid stand, or bench, that is located in an area that has ample space in front and at both sides for working and moving work pieces around the drill press.
3. For best power and safety, the machine should be plugged directly into a dedicated grounded electrical outlet that is within the

supplied cord length of the machine. The use of an extension cord is not recommended.

4. Align the machine so that during use, any projects, debris or kickback will not face aisles, doorways, or other work areas that bystanders may be in. Do not locate or use the machine in damp or wet conditions.
5. Once in place in your shop, make sure that the machine is level. Secure the machine to a bench or stand, with lag screws or bolts (not supplied). This will eliminate any tipping over of the drill press, and reduce any possible vibration during use.

ASSEMBLY



WARNING

THE MACHINE MUST NOT BE PLUGGED IN AND THE POWER SWITCH MUST BE IN THE 'OFF' POSITION UNTIL ASSEMBLY IS COMPLETE.

Tools Required for Assembly



Phillips Screwdriver



Adjustable or 13mm Wrench

Unpacking and Clean-up

1. Carefully finish removing all contents from shipping carton. Compare contents of the shipping carton with the list shown on page 8. Place parts on a protected surface.
2. Report any shipping damage to your local distributor. If parts are missing contact RIKON customer service at 877-884-5167 or techsupport@rikontools.com.
3. Clean all rust protected surfaces. **Do not use**; gasoline, paint thinner, mineral spirits, etc. These may damage painted surfaces.
4. Set packing material and shipping carton to the side. **Do not discard** until the machine has been completely set up and is running properly.

1. Install the column onto the base using the three column mounting bolts. FIG. 1.

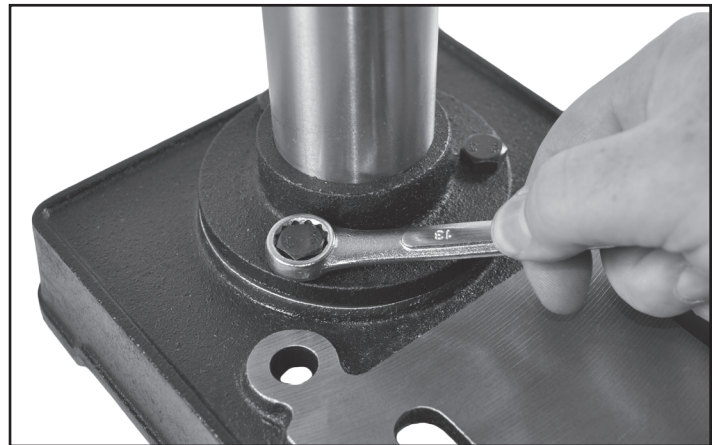

FIG. 1

2. Slide the table onto the column and install the table lock handle through the un-threaded hole on the left of the table support casting. The handle should engage the thread on the right side of the table support casting. FIG. 2.

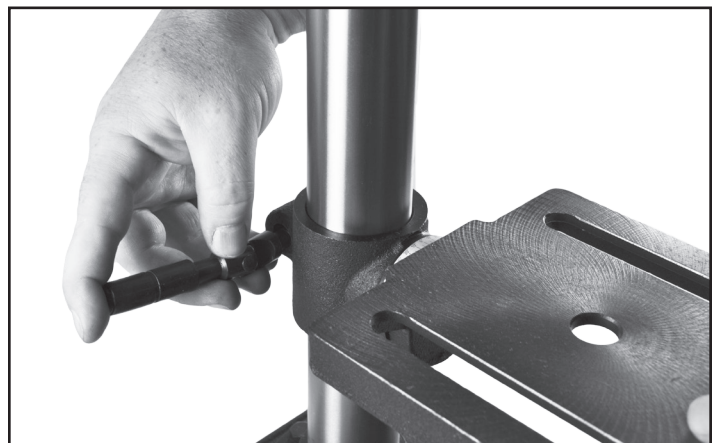

FIG. 2

Parts Diagrams and Parts Lists
can be found on pages 15 to 18.

ASSEMBLY

⚠ WARNING THE MACHINE MUST NOT BE PLUGGED IN AND THE POWER SWITCH MUST BE IN THE 'OFF' POSITION UNTIL ASSEMBLY IS COMPLETE.

3. Slide the drill press head onto the column.
FIG. 3.

4. Center the drill press head over the table and base. Tighten the drill press head into position by locking the two hex screws on the side of the casting. FIG. 4, A.

5. Install the small, belt cover knob on to the right side of the top lid (FIG. 3, A). Open the belt cover and insert the Phillips head screw through the hole in the lid from the inside. Thread the handle on the outside of the belt cover and tighten it in place with a screwdriver.

NOTE: It is important that the tapered chuck mounting hole and tapered spindle are free of any grease, oil or rust protection before they are installed together in step 6.

These tapered surfaces must be absolutely clean for a precision fit, so slipping of the chuck does not occur unless there is extreme rotational pressure during use. This is a safety feature of this type of friction fit joint.

Use ordinary household grease remover to clean these mating surfaces.

6. Slide the 1/2" chuck (FIG. 5, A) over the pre-installed spindle (B). Open the chuck jaws fully and tap into place using a rubber mallet or a hammer and block of wood. This will properly seat the chuck onto the spindle.

NOTE: NEVER HIT THE CHUCK ASSEMBLY WITH A METAL HAMMER. This could damage the chuck or spindle.

7. Install the 3 feed handles onto the threaded holes in the handle hub. FIG. 6.



FIG. 3

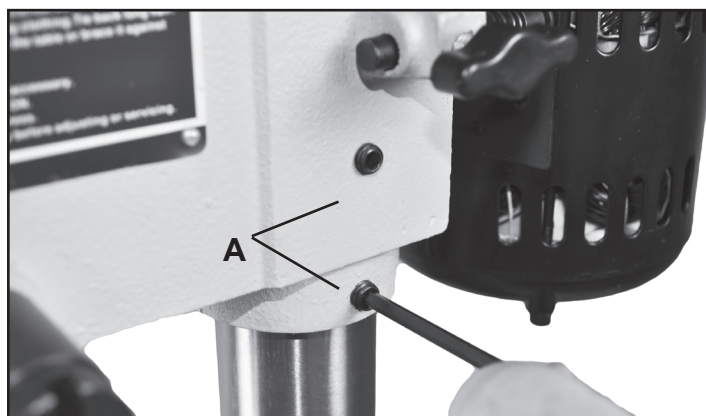

FIG. 4

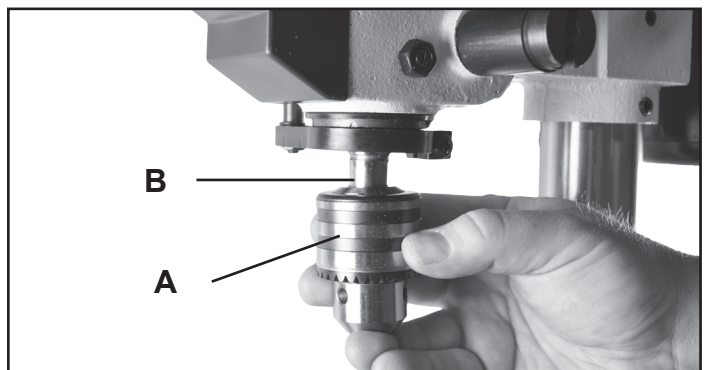

FIG. 5



FIG. 6

ADJUSTMENTS

8. **DEPTH STOP:** The depth stop and scale are found on the left side of the switch box. To adjust, lower the drill chuck until the pointer shows your desired depth on the scale. Loosen the lower nut on the threaded shaft (FIG. 7, A) until it bottoms out on the head casting (B). Tighten upper nut against the lower nut to retain the adjustment.

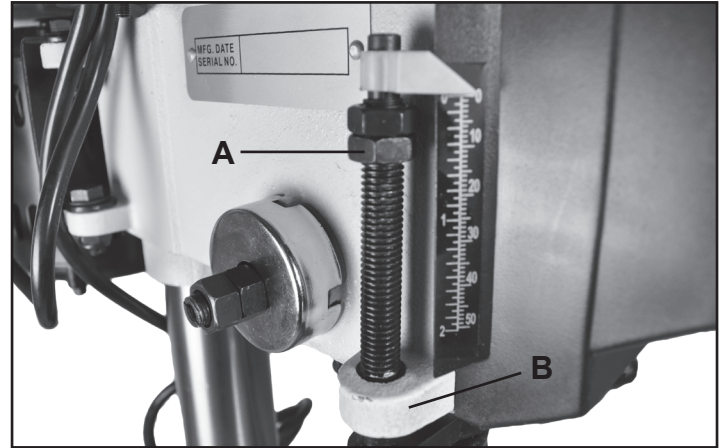

FIG. 7

9. **TABLE TILT:** The drill press table will tilt 0-45 degrees left and right. To tilt, loosen the nut located under the table (FIG. 8, A). Align the "zero" mark on the table (FIG. 9, B) to the desired degree marking on the scale. Tighten the nut under the table to retain the adjustment.

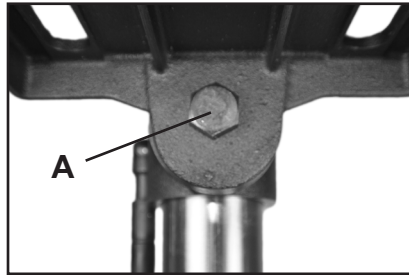

FIG. 8

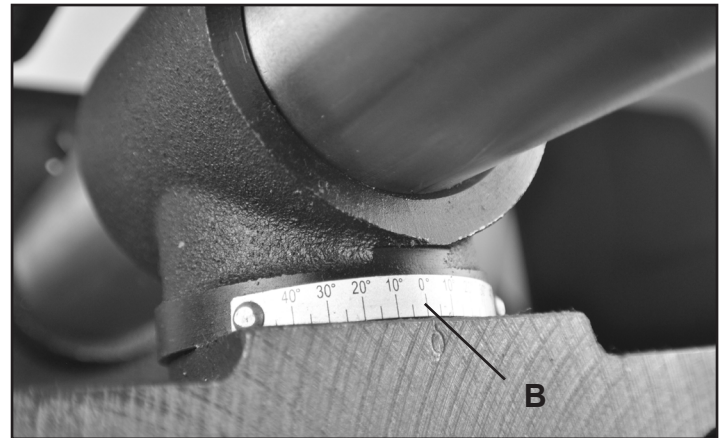

FIG. 9

10. **SPINDLE RETURN SPRING:** The Chuck will automatically return upward to its original starting position when the operating handle is released. The Return Spring Mechanism, FIG. 10, has been preset at the factory and should not require any adjustments. However, should the spring tension decline and need adjustment, follow these steps;

- A. Disconnect the Drill Press from its power source.
- B. Loosen the 2 Spring Cover Nuts (A), but DO NOT REMOVE the nuts from the threaded pin.
- C. Carefully pull out the Spring Cover (B) slightly, and keep a firm grasp on it - DO NOT LET THE COVER SPIN as it keeps the spring from unwinding. Also, DO NOT let the spring end (C) disengage from its notch in the cover!
- D. Pull out the cover just enough so that the notch in the cover clears the nub on the head casting (D).

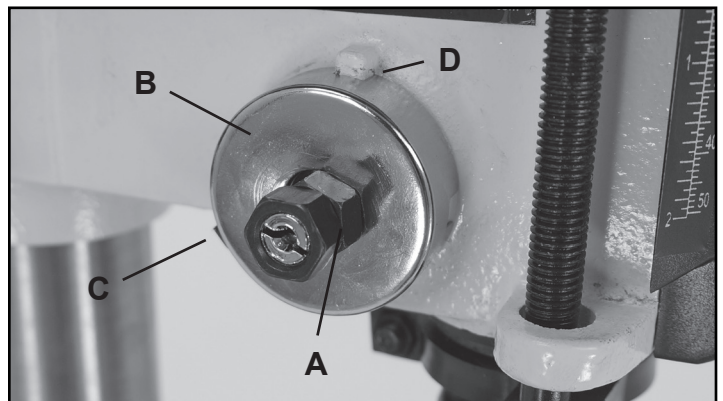

FIG. 10

- E. Rotate the cover to another notch as needed;
 - *CLOCKWISE* to decrease the spring tension,
 - *COUNTER-CLOCKWISE* to increase spring tension.
- F. With the cover in the new position, push it back in place and tighten the spring cover nuts back against the cover to complete the adjustment.

ADJUSTMENTS



WARNING

THE MACHINE MUST NOT BE PLUGGED IN AND THE POWER SWITCH MUST BE IN THE 'OFF' POSITION UNTIL ADJUSTMENTS ARE COMPLETE.

11. CHANGING SPINDLE SPEEDS: The 30-100 Bench Drill Press has five spindle speeds. To change;

A. Lift the cover with the handle to reveal the motor and spindle pulleys, and drive belt. FIG. 11.

B. Loosen the motor lock knob (FIG. 12, A), then move the motor (B) manually toward the feed handle to take tension off of the belt.

C. Move the drive belt to the desired speed position - refer to speed chart inside of the belt cover.

Five Speeds are available:

620, 1100, 1720, 2340, 3100 RPM

D. Manually move the motor away from the feed handle until the belt is tensioned, then tighten the motor lock knob.

NOTE: The belt is properly tensioned when the deflection distance is about 3/8" to 1/2" when pushed by hand. FIG. 13.

E. When the desired speed is set and the motor is locked in place, close the cover, plug in the machine to resume drilling.



FIG. 11

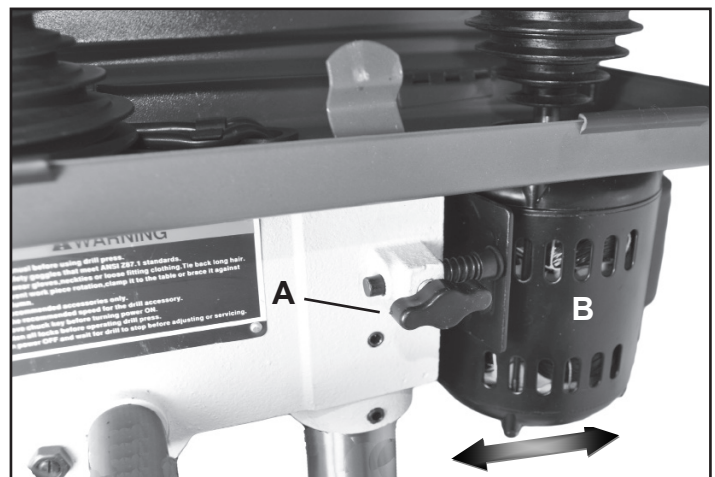

FIG. 12

12. CHANGING THE BELT: To change a worn belt, follow the same basic steps for Changing Spindle Speeds.

- Release the belt tension (11A - 11B)
- Remove the old belt from the pulleys
- Install the new belt onto the pulleys
- Reset the belt tension (11C - 11E)

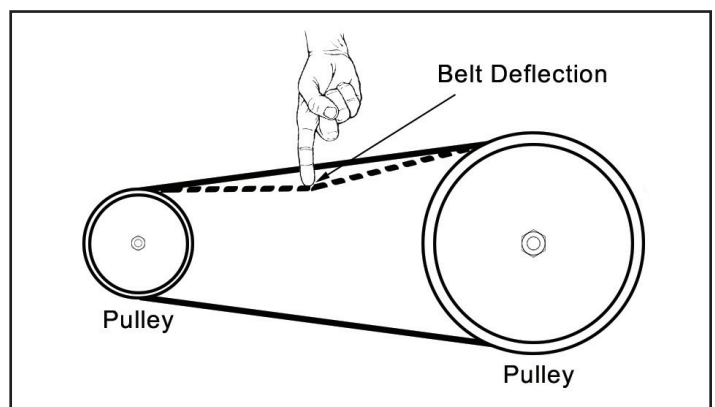

FIG. 13

MAINTENANCE

⚠ WARNING: Turn the power switch “OFF” and disconnect the plug from the outlet prior to adjusting or maintaining the machine. DO NOT attempt to repair or maintain the electrical components of the motor. Contact a qualified service technician for this type of maintenance.

1. Before each use:

- Check the power cord and plug for any wear or damage.
- Check for any loose screws or hardware.
- Check the area to make sure it is clear of any misplaced tools, lumber, cleaning supplies, etc. that could hamper the safe operation of the drill press.

2. To avoid a build-up of wood dust, regularly clean all parts of the machine using a soft cloth, brush or compressed air. A general cleaning should be done after every use to avoid future problems and ensure the machine is in ready condition for the next time it is used.

WARNING: If blowing sawdust, wear proper eye protection to prevent debris from blowing into eyes. The use of dust collection is also advised.

3. Keep the table, column and base free of resin and rust. Clean them regularly with a non-flammable solvent, then coat with a light film of dry lubricant spray, or wax, to keep their surfaces clean. Do not use ordinary oil which will collect dust and hamper the operation of the machine.

4. All of the ball bearings are lifetime lubricated, sealed, and do not need any further care. Keep the drive belts free of oil and grease.

5. Check the belt tension after the first 3-5 hrs. of operation to ensure that the belts have not become stretched and loose from their 'breaking in' use. See page 12 for instructions.

NOTE: Refer to pages 3 - 6 for more information on proper machine usage and user safety.

WIRING DIAGRAM

⚠ WARNING: This machine must be grounded. Replacement of the power supply cable should only be done by a qualified electrician. See page 5 for additional electrical information.

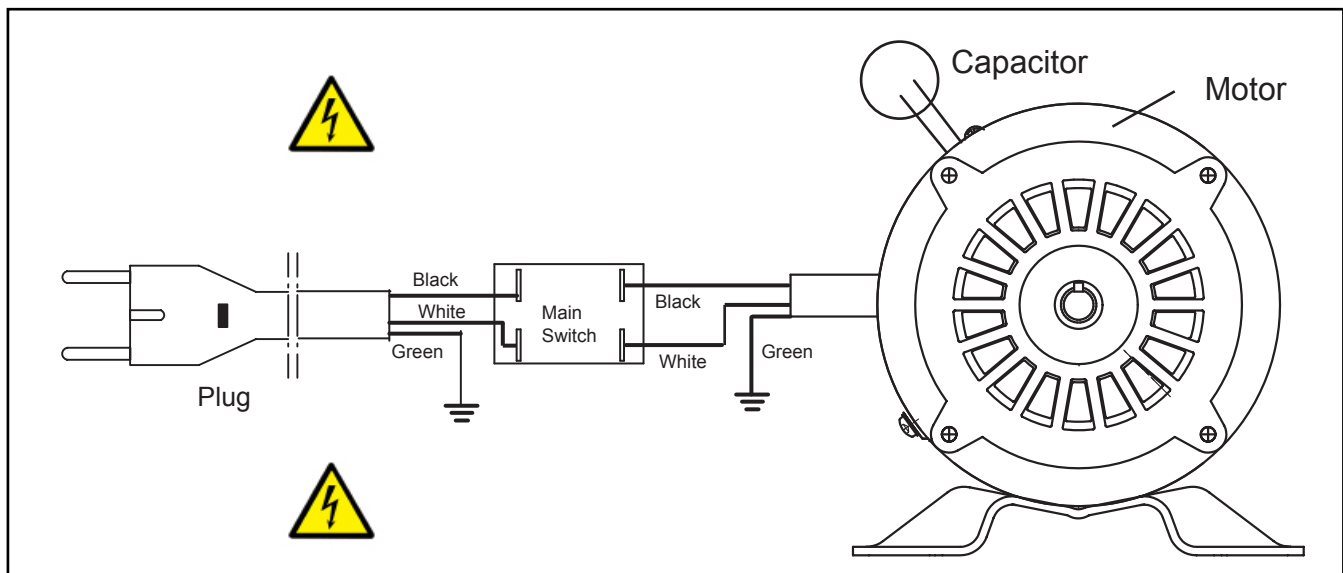

TROUBLESHOOTING



WARNING

THE MACHINE MUST NOT BE PLUGGED IN AND THE POWER SWITCH MUST BE IN THE 'OFF' POSITION UNTIL ADJUSTMENTS ARE COMPLETE.

Problem	Possible Causes	Likely Solutions
Tool will not start.	<ol style="list-style-type: none"> 1. Cord not connected. 2. No power at outlet. 3. Internal damage or wear. 	<ol style="list-style-type: none"> 1. Check that cord is plugged in. 2. Check power at outlet. If outlet is unpowered, turn off tool and check circuit breaker. If breaker is tripped, make sure circuit is right capacity for tool and circuit has no other loads. 3. Have technician service tool.
Tool operates slowly.	Extension cord too long or wire size too small.	Eliminate use of extension cord. If an extension cord is needed, use shorter/heavier gauge cord. See <i>Extension Cords</i> in <i>GROUNDING</i> section.
Performance decreases over time.	<ol style="list-style-type: none"> 1. Accessory dull or damaged. 2. Carbon brushes worn or damaged. 	<ol style="list-style-type: none"> 1. Keep cutting accessories sharp. Replace as needed. 2. Have qualified technician replace brushes.
Excessive noise or rattling.	<ol style="list-style-type: none"> 1. Belt too loose (slipping) or too tight (bearing damage). 2. Spindle dry 3. Loose spindle pulley 4. Loose motor pulley 5. Internal damage or wear. 	<ol style="list-style-type: none"> 1. Properly tension belt. 2. Lubricate spindle 3. Check pulley nut 4. Tighten Set screws 5. Have technician service tool.
Overheating.	<ol style="list-style-type: none"> 1. Forcing machine to work too fast. 2. Accessory misaligned. 3. Accessory dull or damaged. 4. Blocked motor housing vents. 5. Motor being strained by long or small diameter extension cord. 	<ol style="list-style-type: none"> 1. Allow machine to work at its own rate. 2. Check and correct accessory to table alignment. 3. Keep cutting accessories sharp. Replace as needed. 4. Wear ANSI-approved safety goggles and NIOSH-approved dust mask/respirator while blowing dust out of motor using compressed air. 5. Eliminate use of extension cord. If an extension cord is needed, use one with the proper diameter for its length and load. See <i>Extension Cords</i> in <i>GROUNDING</i> section.
Drill bit burns or smokes	<ol style="list-style-type: none"> 1. Incorrect spindle speed 2. Dull drill bit 3. Drilling too slowly 4. Lacking lubrication 	<ol style="list-style-type: none"> 1. Change spindle speed 2. Replace with new bit 3. Drill faster 4. Lubricate cutting area
Drill bit wobbles	<ol style="list-style-type: none"> 1. Bent bit 2. Worn Spindle Bearings 3. Drill bit not in Chuck correctly 4. Chuck not properly installed 	<ol style="list-style-type: none"> 1. Replace drill bit 2. Replace spindle bearings 3. Reinstall drill bit 4. Reinstall Chuck and Arbor assembly
Feed Wheel returns slowly, or too fast	Tension Spring not in adjustment	Adjust Tension Spring.
Drill bit binds	<ol style="list-style-type: none"> 1. Workpiece pinching drill bit 2. Dull drill bit 3. Feed pressure too hard 4. Belts loose 	<ol style="list-style-type: none"> 1. Reposition workpiece, lubricate drill 2. Replace drill bit 3. Pull Feed Handle slowly. 4. Adjust motor and spindle belt tension



Follow all safety precautions whenever diagnosing or servicing the tool. Disconnect power supply before service.

PARTS DIAGRAM & PARTS LIST - A

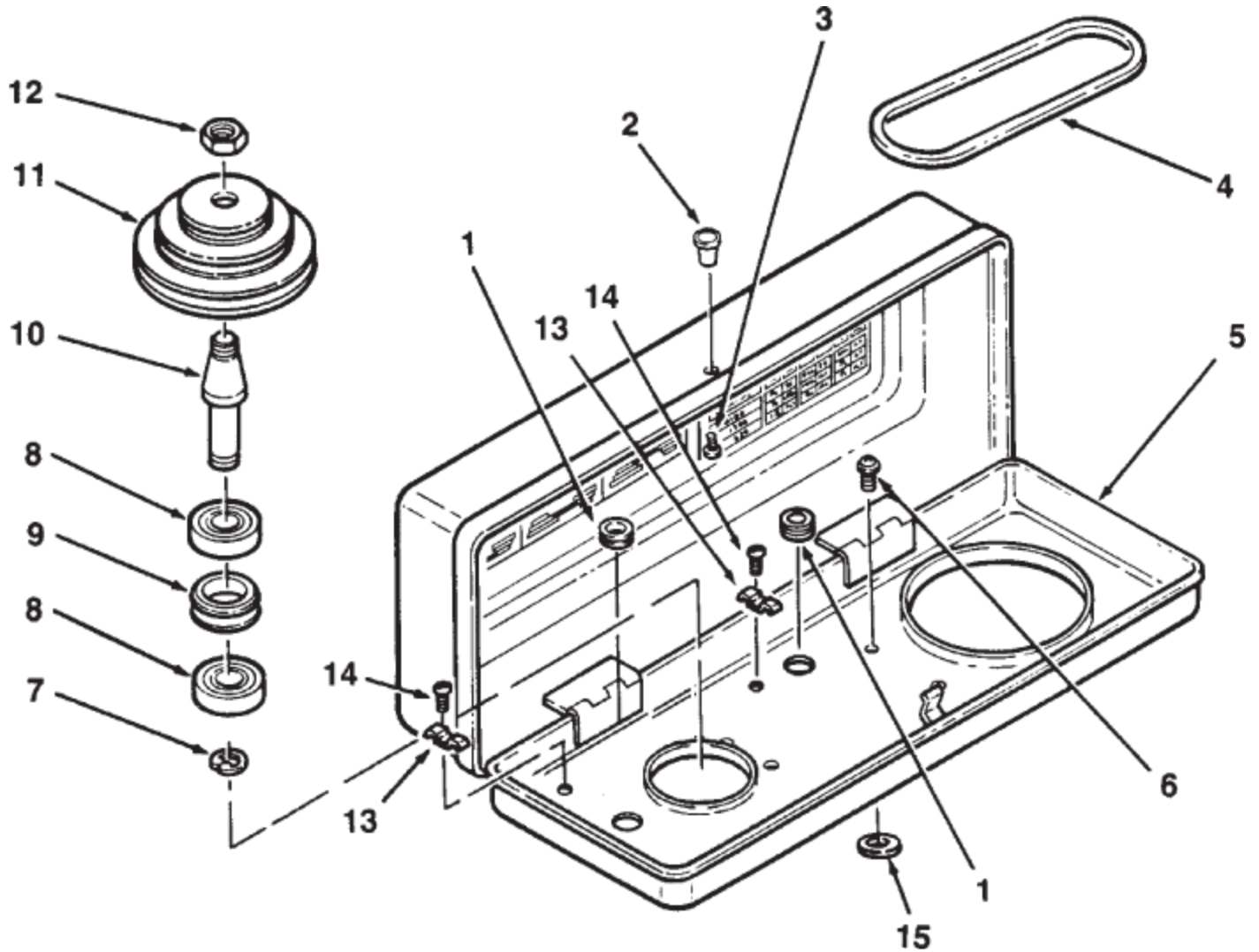

KEY NO.	DESCRIPTION	MFGR. PART NO.	KEY NO.	DESCRIPTION	MFGR. PART NO.
1	Bushing - Rubber	P30-100-1A	9	Spacer	P30-100-9A
2	Knob	P30-100-2A	10	Insert - Pulley	P30-100-10A
3	Screw - Pan Head M5x0.8-1.2	P30-100-3A	11	Pulley - Spindle	P30-100-11A
4	V-Belt 5/16x26	P30-100-4A	12	Nut - Pulley	P30-100-12A
5	Cover Guard with Labels	P30-100-5A	13	Clamp Cord	P30-100-13A
6	Screw - Washer Head	P30-100-6A	14	Screw - Pan Head M5x.08-16	P30-100-14A
7	Retaining Ring	P30-100-7A	15	Washer, Foam	P30-100-15A
8	Ball Bearing 17mm	P30-100-8A			

NOTE: Please reference the Manufacturer's Part Number when calling for Replacement Parts.
For Parts under Warranty, the Serial Number of your machine is required.

PARTS DIAGRAM - B

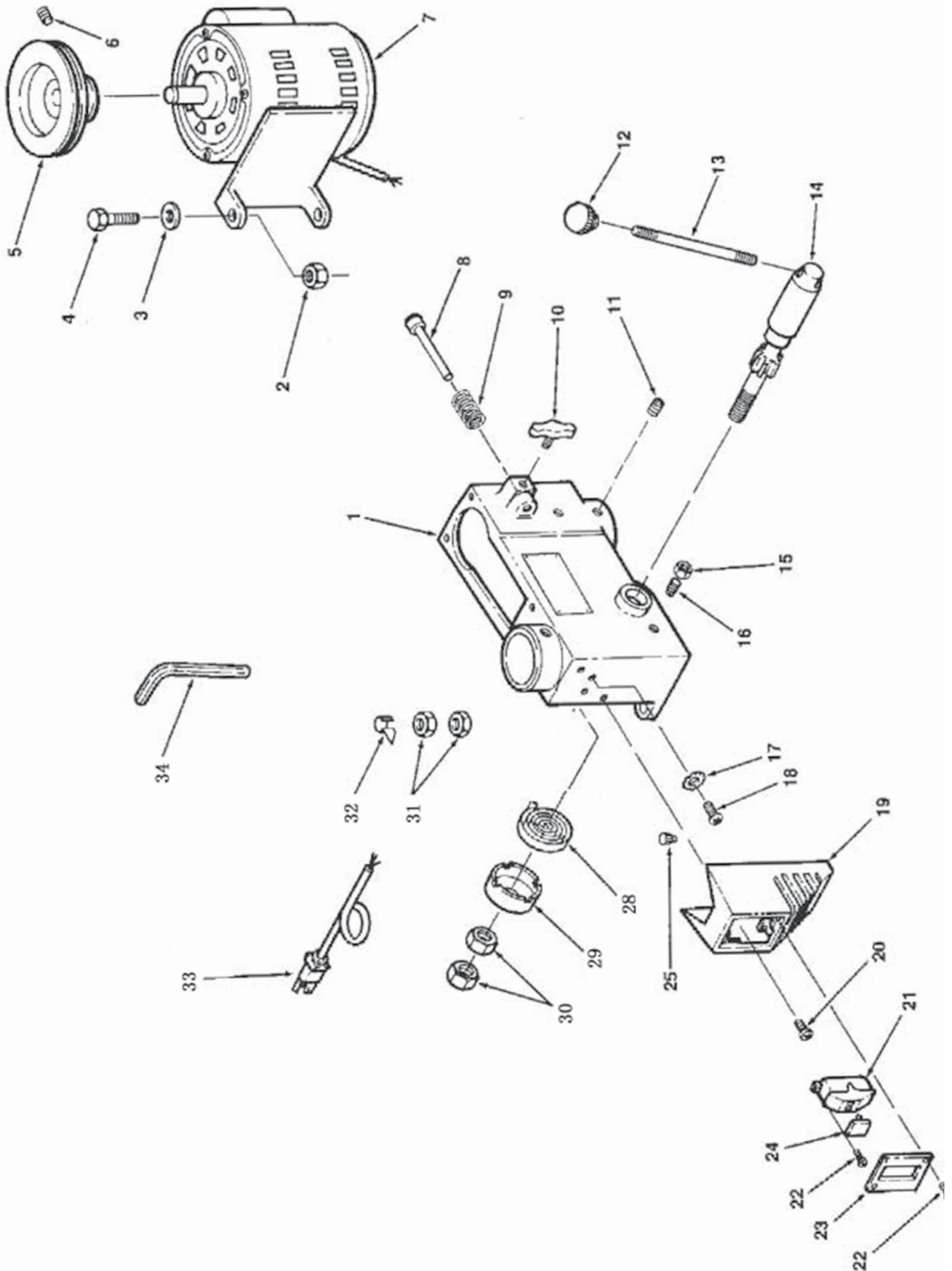

PARTS LIST - B

KEY NO.	DESCRIPTION	MFGR. PART NO.	KEY NO.	DESCRIPTION	MFGR. PART NO.
1	Head with Roll Pin & Trim	P30-100-1B	17	Lock Washer - External .5mm	P30-100-17B
2	Lock Nut - M8x1.25-8	P30-100-2B	18	Screw - Pan Head M5x0.8-8	P30-100-18B
3	Washer 8MM	P30-100-3B	19	Box - Switch with Depth Scale	P30-100-19B
4	Screw - Hex M8x1.25-25	P30-100-4B	20	Screw - Pan Cross Hd M5x0.8-12	P30-100-20B
5	Pulley - Motor	P30-100-5B	21	Switch - Locking	P30-100-21B
6	Screw - Hex Socket Set M6x1.0-10	P30-100-6B	22	Screw - Self Tapping Pan M4x16-8	P30-100-22B
7	Motor	P30-100-7B	23	Cover - Switch Plate	P30-100-23B
8	Stop - Motor	P30-100-8B	24	Key - Switch	P30-100-24B
9	Spring - Motor Stop	P30-100-9B	25	Connector - Wire	P30-100-25B
10	Knob - Motor Adjusting	P30-100-10B	28	Spring - Tension	P30-100-28B
11	Screw - Hex Socket Set M8x1.25-8	P30-100-11B	29	Cap - Spring	P30-100-29B
12	Knobs (3)	P30-100-12B	30	Nut - Hex 3/8-24	P30-100-30B
13	Feed Handles (3)	P30-100-13B	31	Nut - Hex M10x1.5	P30-100-31B
14	Shaft - Pinion	P30-100-14B	32	Pointer	P30-100-32B
15	Nut - Hex M8x1.25	P30-100-15B	33	Power Cord	P30-100-33B
16	Screw - Set M8x1.25	P30-100-16B			

NOTE: Please reference the Manufacturer's Part Number when calling for Replacement Parts.
For Parts under Warranty, the Serial Number of your machine is required.

PARTS DIAGRAMS & PARTS LISTS - C & D

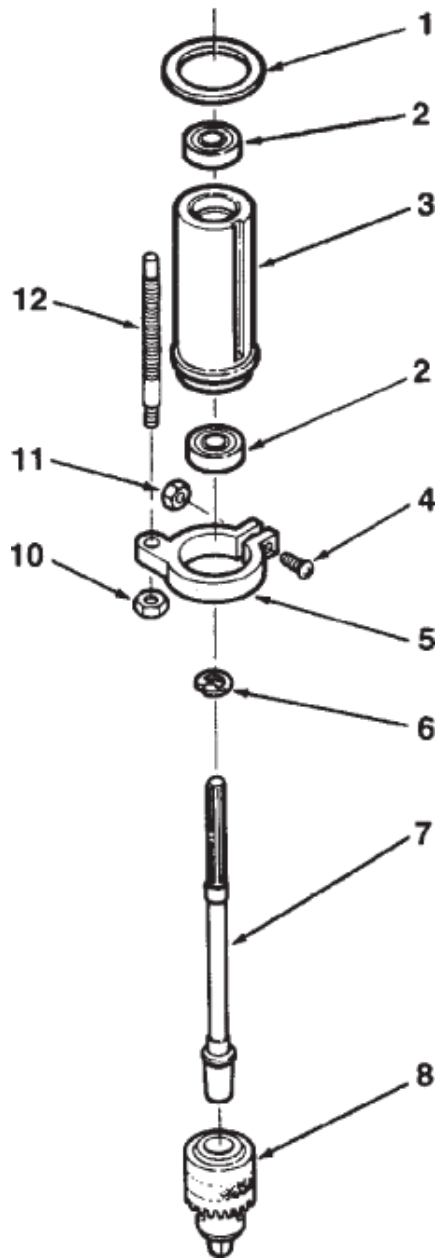

KEY NO.	DESCRIPTION	MFGR. PART NO.
1	Gasket - Quill	P30-100-1C
2	Ball Bearing - 12mm	P30-100-2C
3	Tube - Quill	P30-100-3C
4	Screw - Pan M5x0.8-20	P30-100-4C
5	Stop Collar	P30-100-5C
6	Retaining Ring	P30-100-6C
7	Shaft - Spindle	P30-100-7C
8	Chuck	P30-100-8C
9	Key - Chuck	P30-100-9C
10	Nut - Hex M6x1.0	P30-100-10C
11	Nut - Hex M5x.08	P30-100-11C
12	Rod - Stop	P30-100-12C

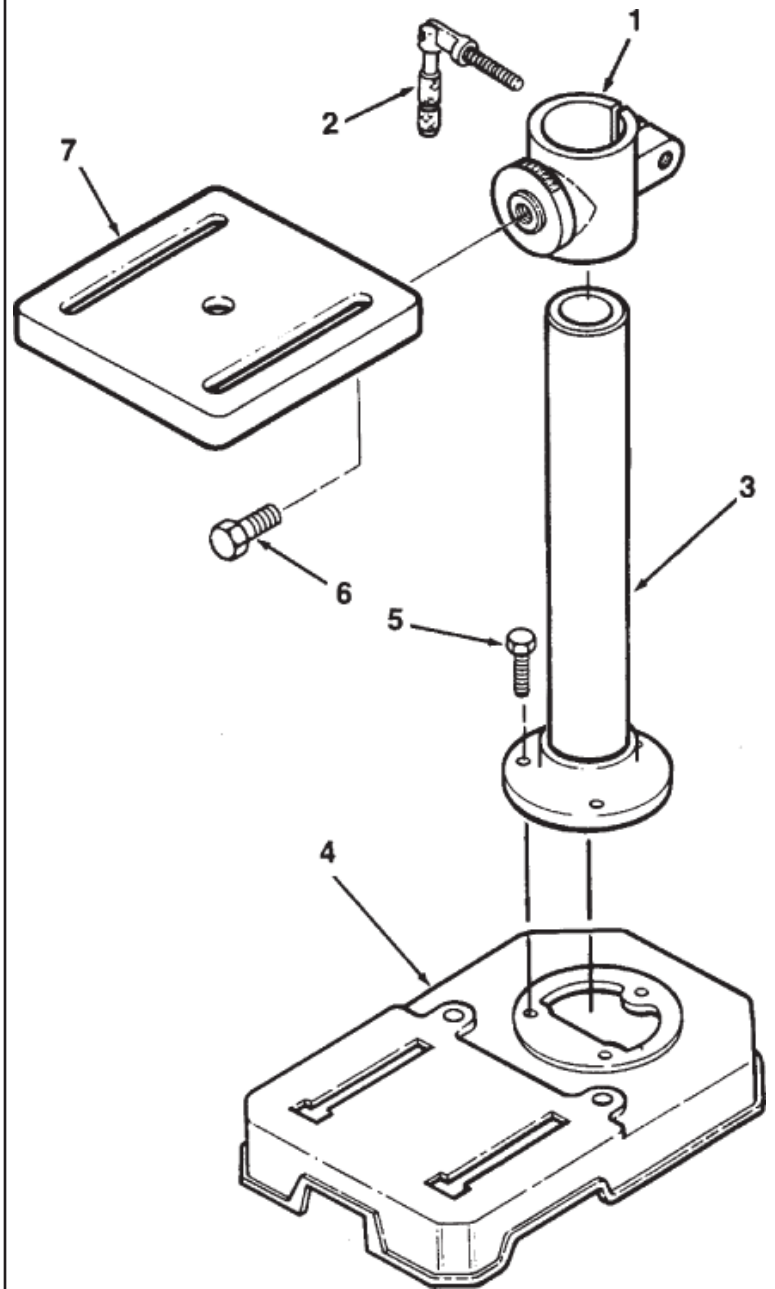

KEY NO.	DESCRIPTION	MFGR. PART NO.
1	Support - Table with Scale	P30-100-1D
2	Support - Lock Handle	P30-100-2D
3	Column	P30-100-3D
4	Base	P30-100-4D
5	Screw - Hex Hd M8x1.25-20	P30-100-5D
6	Screw - Hex Hd 1/2-12x7/8	P30-100-6D
7	Table	P30-100-7D



For more information:
16 Progress Road
Billerica, MA 01821

877-884-5167 / 978-528-5380
techsupport@rikontools.com

