

DETAIL A
SLOT PATTERN

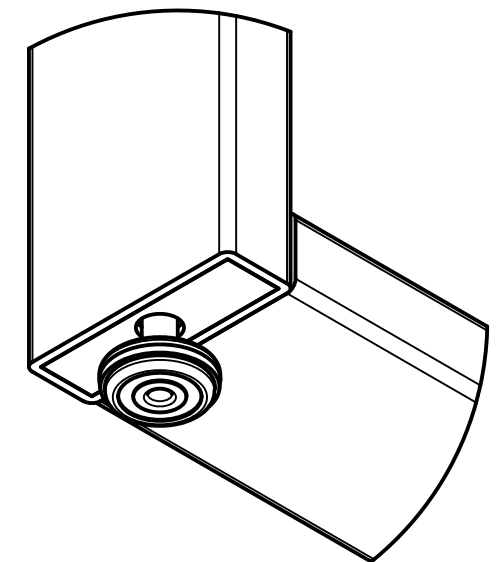
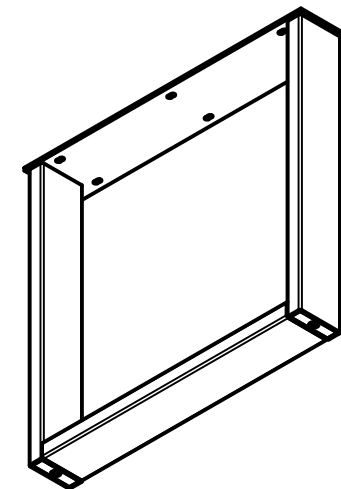

LEVELING FOOT

NOTES:

1. PART TO BE FREE OF BURRS AND SHARP EDGES.
2. ALL WELDS TO BE FREE OF SPATTER.
3. TOP LENGTHS GREATER THAN 16 GET CENTER HOLES

HEIGHT: 10" - 40" OPTIONS IN 1" INCREMENTS

WIDTH: 10" - 40" OPTIONS IN 1" INCREMENTS