

# **Z A E R O**

D E S I G N

## **EVO-1 DIFFUSER SPLITTERS FOR BMW 1 SERIES F20 | F21**

INSTALLATION MANUAL

# EVO-1 DIFFUSER SPLITTERS FOR BMW 1 SERIES F20 | F21

①

## TEST FITTING

Line up the Diffuser splitters on the OEM rear bumper. Align the Diffuser Splitters so that the edges of the splitter ending with the edges of the OEM rear bumper towards the wheels. Also the center part has to end with the OEM rear diffuser towards the exhaust tips.

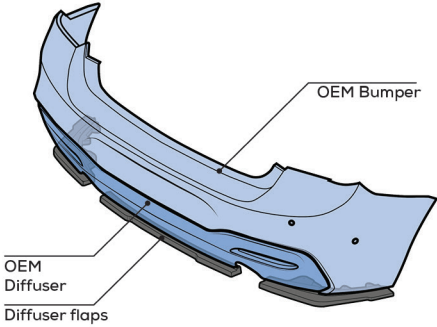

②

## PRE DRILLING THE HOLES

With the Diffuser splitters in the correct position, you have to drill the holes through the OEM rear bumper with a 6mm drill. Please note, you can use three mounting points of the OEM rear bumper on each side of the diffuser side splitter.

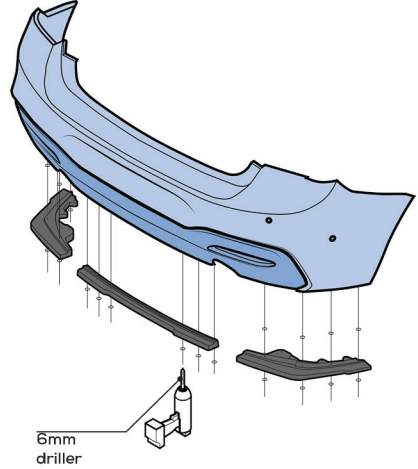

## REMOVING PROTECTION FILM

③

1. Please clean the OEM rear bumper and make sure that it is free of grease. You can now take off the protection film on the Diffuser splitters.
2. Apply the polyethylene glue to the areas of the Diffuser splitters as shown below and position the parts on the OEM rear bumper - make sure the glue spreads evenly.

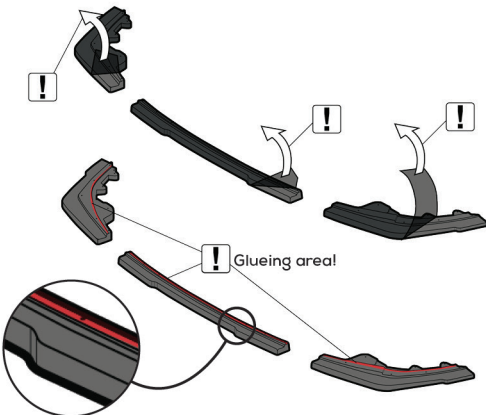

## APPLYING THE DIFFUSER TO THE BUMPER

④

Use the screws to fix the Diffuser splitters on the OEM rear bumper by the pre-drilled holes - secure the screws by adding the washers and nuts.

