

2023

FY45

VIPER
LIFT TRUCKS



STANDARD FEATURES

- 10,000lb Base Capacity
- 3 Stage Mast
- Full Free Lift
- 90" Lowered Mast Height
- 189" Max Raised Fork Height
- Premium Air Pneumatic tires
- Backup Alarm
- Rear View Mirrors
- LED Front and Rear Lights
- Integrated LED Turn Signals
- Tilt Steering Column
- Digital Systems Monitor Display
- Rubber Floor mat
- Load Backrest
- 3 Way Hydraulics Plumbed to Carriage
- 12mo/2000hr Manufacturer Warranty
- 1 Year/2000hr Engine Warranty





2023

FY45

SPECIFICATIONS

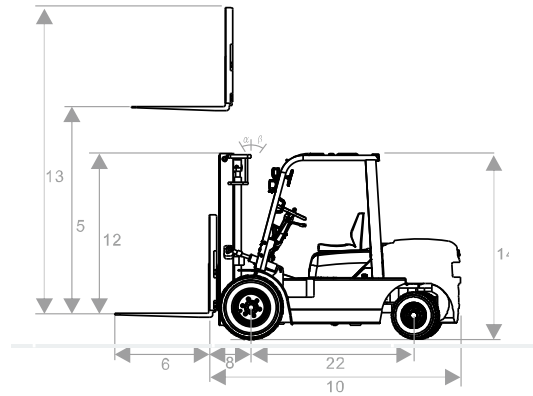
POWER TYPE LPG	LPG
BASE CAPACITY	10000 LBS
CAPACITY 24" LC @189"	8000 LBS
SERVICE WEIGHT	13250 LBS
TIRE SIZE (FRONT)	250-15
TIRE SIZE (REAR)	6.50-10-10PR
WHEELBASE	67"
MAST TILT ANGLE (F/R)	6/12
LIFT HEIGHT (3 STAGE)	189"
LOWERED HEIGHT	90"
FREE LIFT	73"
LENGTH (LESS FORKS)	114"
WIDTH	55.5"
HEIGHT TO OVERHEAD GUARD	85"
TURNING RADIUS	106"
GROUND CLEARANCE	5.5"
MAX GRADABILITY	20%
TRANSMISSION	AUTO
TRANSMISSION SPEEDS	1 FWD / 1 RVS



 RASA: Right-Angle Stack Aisle
 a: Safety Clearance
 b: Length of Loading
 v: Turning radius (inside)

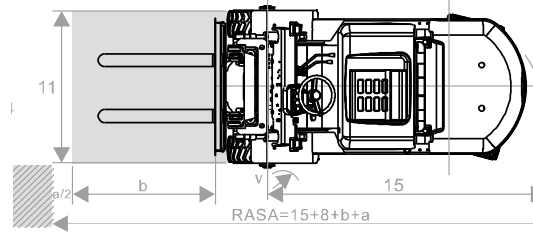

Engine model may vary



VIPER
LIFT TRUCKS



2023

FY45

PICK YOUR COLOR!

ORANGE



RED

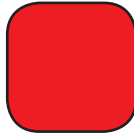

GREEN



ACID GREEN



SKY BLUE



ROYAL BLUE



SILVER



FROST GREY



WWW.VIPERLIFTTRUCKS.COM

FACTORY INSTALLED OPTIONS*

SOLID TIRES (4)

SOLID TIRES (6)

SIDE SHIFTER

SIDE SHIFT FORK POSITIONER

DUAL DRIVE W/WIDE CARRIAGE

FULL SUSPENSION SEAT

CAB W/HEAT, WIPERS, LED LIGHTS

AIR CONDITIONING

DUAL AIR FILTER (N/A W/ CAB)

VERTICAL EXHAUST

FIRE EXTINGUISHER

STROBE LIGHT

REAR WORK LIGHT

4TH VALVE, LEVER AND HOSEING

REAR HORN HANDLE/BUTTON

EATON STEERING



**EXTENDED WARRANTIES AVAILABLE
INQUIRE WITH YOUR REPRESENTATIVE
FOR FURTHER DETAILS**





VIPER

VIPER
LIFT TRUCKS

25

VIPER

OIL FILTER

VIPER
LIFT TRUCKS
GENUINE PARTS

VIPER
LIFT TRUCKS

GENUINE PARTS

VIPER
LIFT TRUCKS

GENUINE PARTS

VIPER
LIFT TRUCKS

GENUINE PARTS