

# 2021 FD50S



## STANDARD FEATURES

- 11,000lb Base Capacity
- 3 Stage Mast
- Full Free Lift
- 91" Lowered Mast Height
- 189" Max Raised Fork Height
- Premium Air Pneumatic tires
- EPA Tier 4 Final Cummins engine QSF2.8L Turbo Diesel Engine
- Engine Features 3cyl 65 HP and 200 ft/lb TQ
- Backup Alarm
- Rear View Mirrors
- LED Front and Rear Lights
- Integrated LED Turn Signals
- Tilt Steering Column
- Digital Systems Monitor Display
- Rubber Floor mat
- Load Backrest
- 3 Way Hydraulics Plumbed to Carriage
- 48" Forks
- 12mo/2000hr Manufacturer Warranty
- 1 Year/2000hr Cummins Engine Warranty



# 2021 FD50S

## SPECIFICATIONS

POWER TYPE	<b>DIESEL</b>
BASE CAPACITY	<b>11000 LBS</b>
CAPACITY 24" LC @189"	<b>8100 LBS</b>
SERVICE WEIGHT	<b>16530 LBS</b>
TIRE SIZE (FRONT)	<b>300-15-18 PR</b>
TIRE SIZE (REAR)	<b>7.00-12-12 PR</b>
WHEELBASE	<b>83"</b>
MAST TILT ANGLE (F/R)	<b>6/12</b>
LIFT HEIGHT (3 STAGE)	<b>189"</b>
LOWERED HEIGHT	<b>91"</b>
FREE LIFT	<b>73"</b>
LENGTH (LESS FORKS)	<b>128"</b>
WIDTH	<b>57.5"</b>
HEIGHT TO OVERHEAD GUARD	<b>92.12"</b>
TURNING RADIUS	<b>114.5"</b>
GROUND CLEARANCE	<b>6"</b>
MAX GRADABILITY	<b>20%</b>
TRANSMISSION	<b>AUTO</b>
TRANSMISSION SPEEDS	<b>2 FWD / 1 RVS</b>

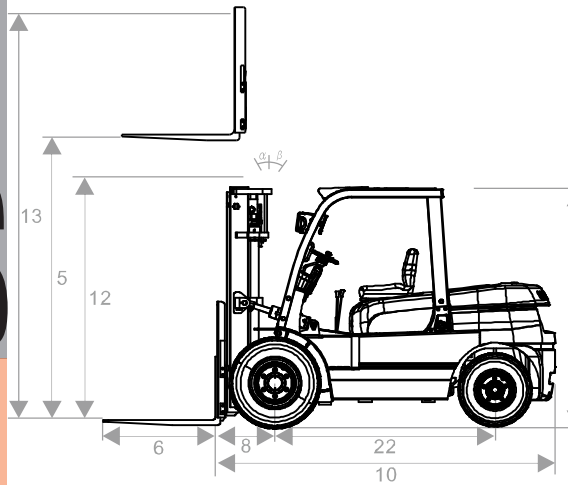

 RASA: Right-Angle Stack Aisle  
 a: Safety Clearance  
 b: Length of Loading  
 v: Turning radius (inside)

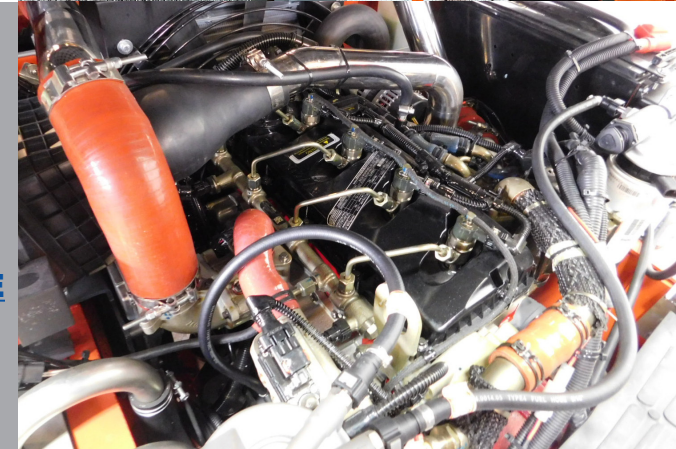
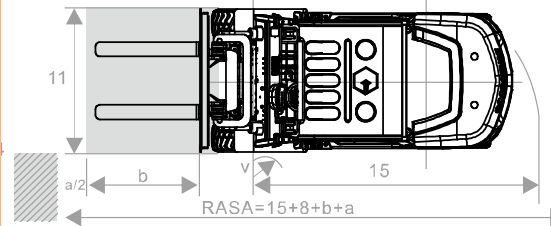

[CLICK FOR ENGINE BROCHURE](#)



**VIPER**  
LIFT TRUCKS

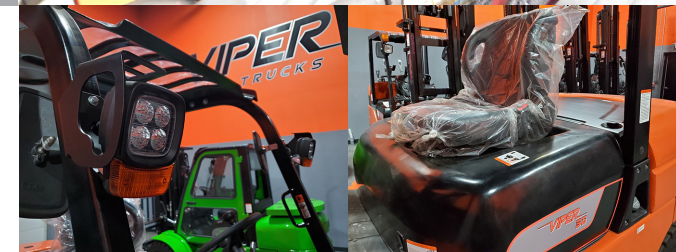

# 2021 FD50S

## PICK YOUR COLOR!

**ORANGE**



**RED**

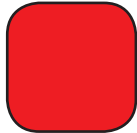

**GREEN**



**ACID GREEN**



**SKY BLUE**



**ROYAL BLUE**



**SILVER**



**FROST GREY**



## FACTORY INSTALLED OPTIONS\*

SIDE SHIFTER

SIDE SHIFT FORK POSITIONER

SIDE SHIFT FORK POSITIONER

w/WIDE CARRIAGE

DUAL DRIVE WIDE CARRIAGE

FULL SUSPENSION SEAT

CAB W/HEAT, WIPERS, LED LIGHTS

AIR CONDITIONING

FIRE EXTINGUISHER

STROBE LIGHT

REAR WORK LIGHT

4TH VALVE, LEVER AND HOISING

REAR HORN HANDLE/BUTTON

EATON STEERING

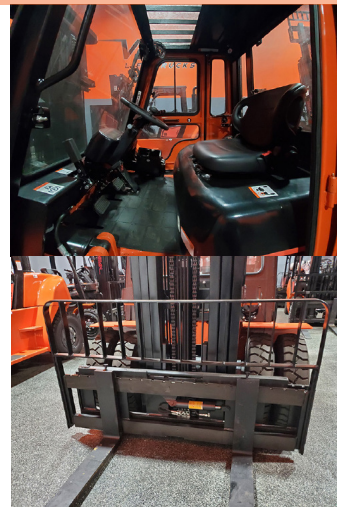

**EXTENDED WARRANTIES AVAILABLE  
INQUIRE WITH YOUR REPRESENTATIVE  
FOR FURTHER DETAILS**

**VIPER**  
LIFT TRUCKS

WWW.VIPERLIFTTRUCKS.COM



VIPER

VIPER  
LIFT TRUCKS

25

VIPER

OIL FILTER

VIPER  
LIFT TRUCKS  
GENUINE PARTS

VIPER  
LIFT TRUCKS

GENUINE PARTS

VIPER  
LIFT TRUCKS

GENUINE PARTS

VIPER  
LIFT TRUCKS

GENUINE PARTS