

# 2023

# FD35

## STANDARD FEATURES

- 8,000lb Base Capacity
- 3 Stage Mast
- Full Free Lift
- 88" Lowered Mast Height
- 189" Max Raised Fork Height
- Premium Air Pneumatic tires
- EPA Tier 4 Final Diesel Engine
- Backup Alarm
- Rear View Mirrors
- LED Front and Rear Lights
- Integrated LED Turn Signals
- Tilt Steering Column
- Twin USB Power Ports for Electric personal or Business Devices
- Digital Systems Monitor Display
- Rubber Floor mat
- Load Backrest
- 3 Way Hydraulics Plumbed to Carriage
- 12mo/2000hr Manufacturer Warranty



# 2023

# FD35

## SPECIFICATIONS

POWER TYPE	<b>DIESEL</b>
BASE CAPACITY	<b>8000 LBS</b>
CAPACITY 24" LC @189"	<b>5400 LBS</b>
SERVICE WEIGHT	<b>10700 LBS</b>
TIRE SIZE (FRONT)	<b>28x9-15-14PR</b>
TIRE SIZE (REAR)	<b>6.50-10-10PR</b>
WHEELBASE	<b>67"</b>
MAST TILT ANGLE (F/R)	<b>6/12</b>
LIFT HEIGHT (3 STAGE)	<b>189"</b>
LOWERED HEIGHT	<b>88"</b>
FREE LIFT	<b>73"</b>
LENGTH (LESS FORKS)	<b>109"</b>
WIDTH	<b>48"</b>
HEIGHT TO OVERHEAD GUARD	<b>85"</b>
TURNING RADIUS	<b>97.6"</b>
GROUND CLEARANCE	<b>5.5"</b>
MAX GRADABILITY	<b>20%</b>
TRANSMISSION	<b>AUTO</b>
TRANSMISSION SPEEDS	<b>1 FWD / 1 RVS</b>

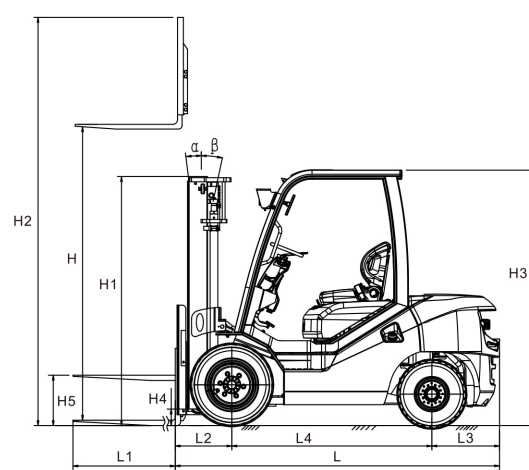

RASA: Right-Angle Stack Aisle

a: Safety Clearance

b: Load Length

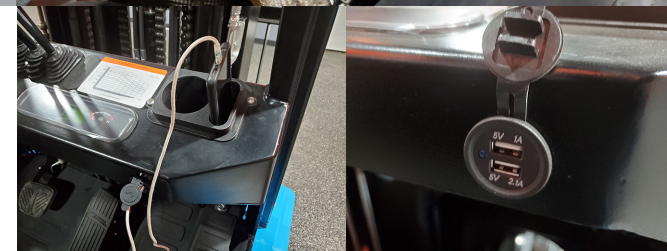
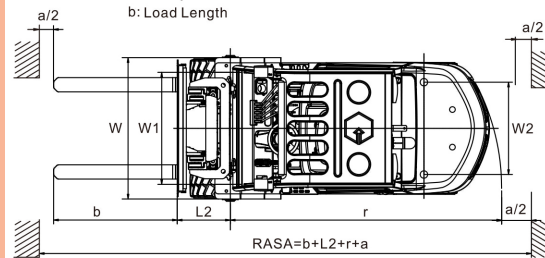

Engine model may vary

**VIPER**  
LIFT TRUCKS



# 2023

# FD35

## PICK YOUR COLOR!

**ORANGE**



**RED**



**GREEN**



**ACID GREEN**



**SKY BLUE**

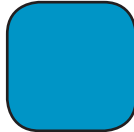

**ROYAL BLUE**



**SILVER**

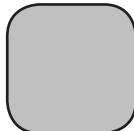

**FROST GREY**



## FACTORY INSTALLED OPTIONS\*

DUAL FUEL ENGINE

SOLID TIRES (4)

SOLID TIRES (6)

SIDE SHIFTER

SIDE SHIFT FORK POSITIONER

DUAL DRIVE W/WIDE CARRIAGE

FULL SUSPENSION SEAT

CAB W/HEAT, WIPERS, LED LIGHTS

AIR CONDITIONING

DUAL AIR FILTER (N/A W/ CAB)

VERTICAL EXHAUST

FIRE EXTINGUISHER

STROBE LIGHT

REAR WORK LIGHT

4TH VALVE, LEVER AND HOISING

REAR HORN HANDLE/BUTTON

EATON STEERING



**EXTENDED WARRANTIES AVAILABLE  
INQUIRE WITH YOUR REPRESENTATIVE  
FOR FURTHER DETAILS**

**VIPER**  
LIFT TRUCKS

WWW.VIPERLIFTTRUCKS.COM



VIPER

VIPER  
LIFT TRUCKS

25

VIPER

VIPER  
LIFT TRUCKS  
GENUINE PARTS

VIPER  
LIFT TRUCKS

GENUINE PARTS

VIPER  
LIFT TRUCKS

GENUINE PARTS

VIPER  
LIFT TRUCKS

GENUINE PARTS

OIL FILTER