

# SX460 AUTOMATIC VOLTAGE REGULATOR (AVR) SPECIFICATION, INSTALLATION AND ADJUSTMENTS

## General description

SX460 is a half-wave phase-controlled thyristor type Automatic Voltage Regulator (AVR) and forms part of the excitation system for a brush-less generator.

In addition to regulating the generator voltage, the AVR circuitry includes under-speed and sensing loss protection

features. Excitation power is derived directly from the generator terminals.

Positive voltage build up from residual levels is ensured by the use of efficient semiconductors in the power circuitry of the AVR.

The AVR is linked with the main stator windings and the exciter field windings to provide closed loop control of the output voltage with load regulation of +/- 1.0%.

In addition to being powered from the main stator, the AVR also derives a sample voltage from the output windings for voltage control purposes. In response to this sample voltage, the AVR controls the power fed to the exciter field, and hence the main field, to maintain the machine output voltage within the specified limits, compensating for load, speed, temperature and power factor of the generator.

A frequency measuring circuit continually monitors the generator output and provides output under-speed protection of the excitation system, by reducing the output voltage proportionally with speed below a pre-settable threshold. A manual adjustment is provided for factory setting of the under frequency roll off point, (UFRO). This can easily be changed to 50 or 60 Hz in the field by push-on link selection.

Provision is made for the connection of a remote voltage trimmer, allowing the user fine control of the generator's output.

## Technical specification

### INPUT

Voltage	Jumper selectable 95-132V ac or 190-264V ac
Frequency	50-60 Hz nominal
Phase	1

### OUTPUT

Voltage	max 90V dc at 207V ac input
Current	continuous 4 A dc Intermittent 6 A for 10 secs
Resistance	15 ohms minimum

### REGULATION

+/- 1.0% (see note 1)

### THERMAL DRIFT

0.05% per deg. C change in AVR ambient (note 2)

### TYPICAL SYSTEM RESPONSE

AVR response	20 ms
Filed current to 90%	80 ms
Machine Volts to 97%	300 ms

### EXTERNAL VOLTAGE ADJUSTMENT

+/-10% with 1 k ohm 1 watt trimmer (see note 3)

### UNDER FREQUENCY PROTECTION

Set point	95% Hz (see note 4)
Slope	170% down to 30 Hz

### UNIT POWER DISSIPATION

10 watts maximum

### BUILD UP VOLTAGE

4 Volts @ AVR terminals

### ENVIRONMENTAL

Vibration	20-100 Hz	50mm/sec
	100Hz – 2kHz	3.3g
Operating temperature		-40 to +70°C
Relative Humidity	0-70°C	95% (see note 5)
Storage temperature		-55 to +80°C

### NOTES

1. With 4% engine governing
2. After 10 minutes.
3. Applies to Mod status F onwards. Generator de-rate may apply. Check with factory.
4. Factory set, semi-sealed, jumper selectable
5. Non condensing.

## DESIGN DETAIL

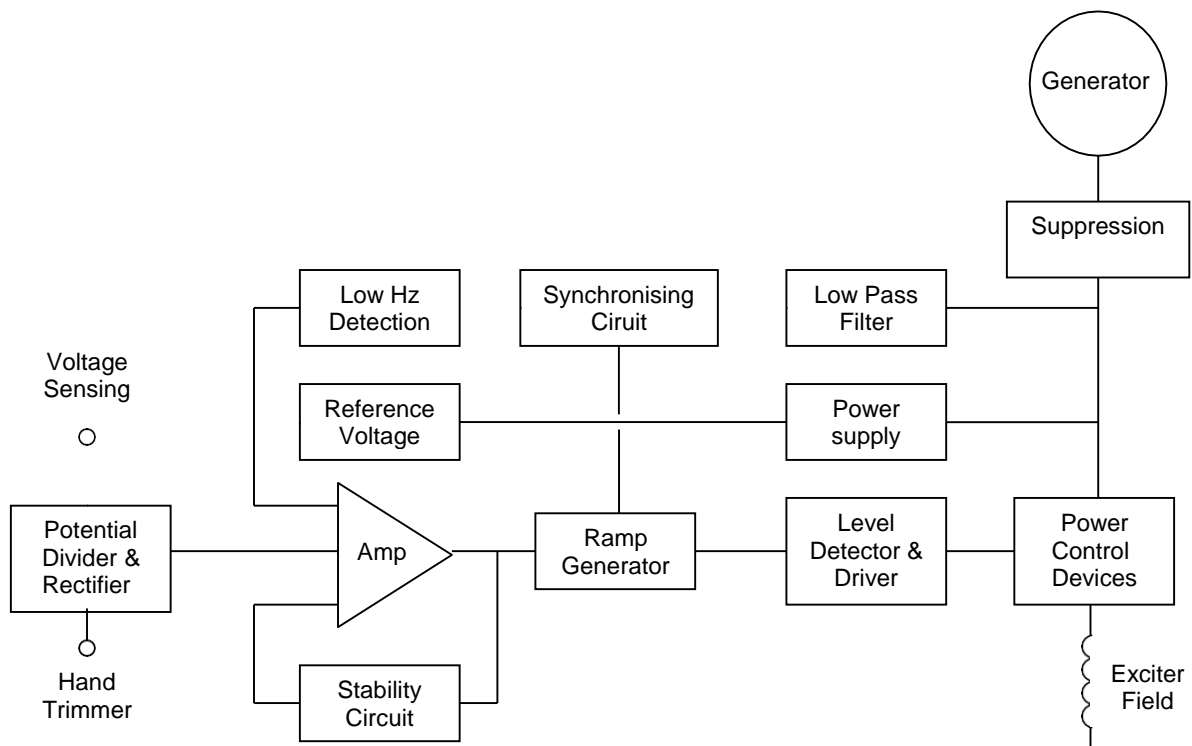

The main functions of the AVR are:

Potential Divider and Rectifier takes a proportion of the generator output voltage and attenuates it. This input chain of resistors includes the range potentiometer and hand trimmer which adjust the generator voltage. A rectifier converts the a.c. into d.c. for further processing.

The Amplifier (Amp) compares the sensing voltage to the Reference Voltage and amplifies the difference (error) to provide a controlling signal for the power devices. The Ramp Generator and Level Detector and Driver infinitely control the conduction period of the Power Control Devices and hence provides the excitation system with the required power to maintain the generator voltage within specified limits.

The Stability Circuit provides adjustable negative ac feedback to ensure good steady state and transient performance of the control system.

The Low Hz Detector measures the period of each electrical cycle and causes the reference voltage to be reduced approximately linearly with speed below a presettable threshold. A Light Emitting Diode gives indication of underspeed running.

The Synchronising circuit is used to keep the Ramp Generator and Low Hz Detector locked to the generator waveform period.

The Low Pass Filter prevents distorted waveforms affecting the operation of the AVR.

Power Control Devices vary the amount of exciter field current in response to the error signal produced by the Amplifier.

Suppression components are included to prevent sub cycle voltage spikes damaging the AVR components and also to reduce the amount of conducted noise on the generator terminals.

The Power Supply provides the required voltages for the AVR circuitry.

## FITTING AND OPERATING

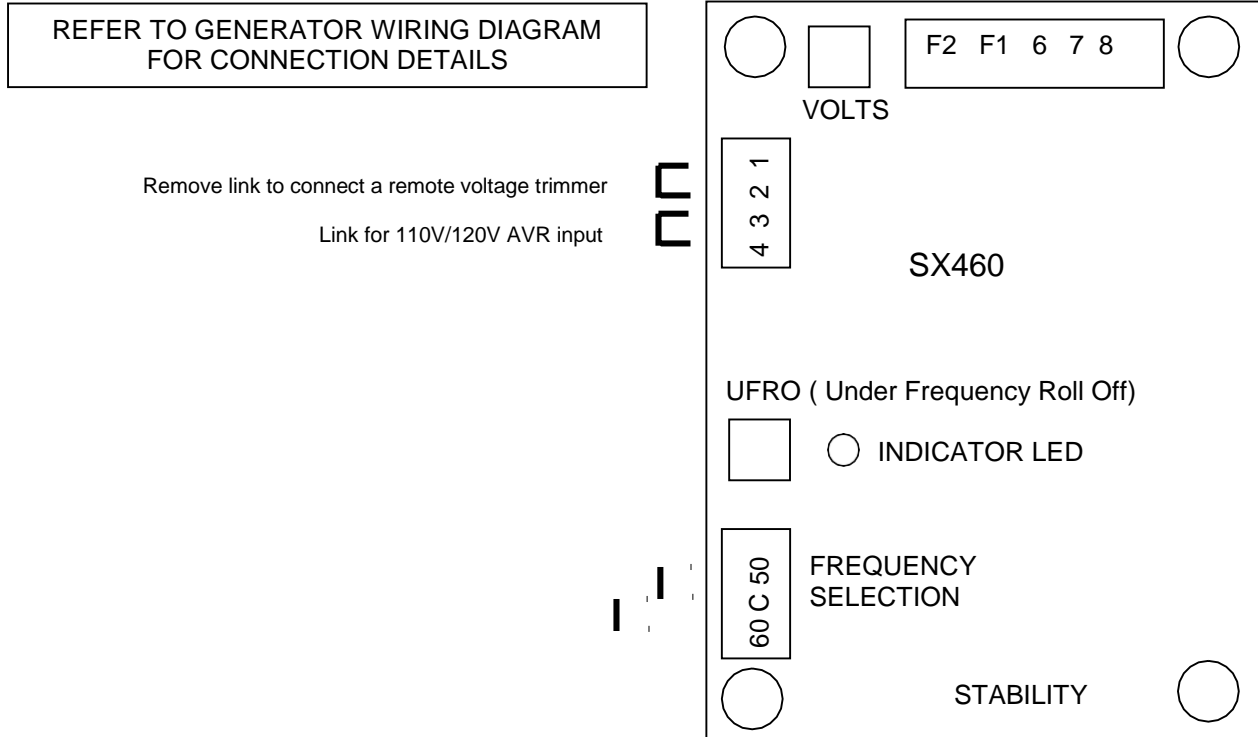

SUMMARY OF AVR CONTROLS		
CONTROL	FUNCTION	DIRECTION
VOLTS STABILITY UFRO	TO ADJUST GENERATOR OUTPUT VOLTAGE TO PREVENT VOLTAGE HUNTING TO SET THE UFRO KNEE POINT	CLOCKWISE INCREASES OUTPUT VOLTAGE CLOCKWISE INCREASE THE DAMPING EFFECT CLOCKWISE REDUCES THE KNEE POINT

### ADJUSTMENT OF AVR CONTROLS

#### VOLTAGE ADJUSTMENT

The generator output voltage is set at the factory, but can be altered by careful adjustment of the VOLTS control on the AVR board, or by the external hand trimmer if fitted. Terminals 1 and 2 on the AVR will be fitted with a shorting link if no hand trimmer is required. Terminals 3 and 4 are linked only for special low voltage applications.

**CAUTION** Do not increase the voltage above the rated generator voltage. If in doubt, refer to the rating plate mounted on the generator case.

**CAUTION** Do not ground any of the hand trimmer terminals as these could be above earth potential. Failure to observe this could cause equipment damage.

If a replacement AVR has been fitted or re-setting of the VOLTS adjustment is required, proceed as follows:

#### CAUTION

1. Before running generator, turn the VOLTS control fully anti-clockwise.
2. Turn remote volts trimmer (if fitted) to midway position.
3. Turn STABILITY control to midway position.
4. Connect a suitable voltmeter (0-300V ac) across line to neutral of the generator.
5. Start generator set, and run on no load at nominal frequency e.g. 50-53Hz or 60-63Hz.
6. If the red Light Emitting Diode (LED) is illuminated, refer to the Under Frequency Roll Off (UFRO) adjustment.
7. Carefully turn VOLTS control clockwise until rated voltage is reached.
8. If instability is present at rated voltage, refer to stability adjustment, then re-adjust voltage if necessary.
9. Voltage adjustment is now completed.

## FITTING AND OPERATING

### **STABILITY ADJUSTMENT**

The AVR includes a stability or damping circuit to provide good steady state and transient performance of the generator.

The correct setting can be found by running the generator at no load and slowly turning the stability control anti-clockwise until the generator voltage starts to become unstable.

The optimum or critically damped position is slightly clockwise from this point (i.e. where the machine volts are stable but close to the unstable region).

### **UNDER FREQUENCY ROLL OFF (UFRO) ADJUSTMENT**

The AVR incorporates an underspeed protection circuit which gives a volts/Hz characteristic when the generator speed falls below a presettable threshold known as the "knee" point.

The red Light Emitting Diode (LED) gives indication that the UFRO circuit is operating.

The UFRO adjustment is preset and sealed and only requires the selection of 50 / 60Hz using the jumper link.

For optimum setting, the LED should illuminate as the frequency falls just below nominal, i.e. 47Hz on a 50Hz system or 57Hz on a 60Hz system.