

Product Specification of:

## O<sub>2</sub> - Medical Sensor

Type: SS-11A

Part. No.:

**Key Features:** Long life cell that shows high signal stability at low cross interferences to anesthesia gases combined with superior linearity over the entire range

All characteristics are based on conditions at 25°C, 50% RH and 1013 hPa

Electrical Connector:	3.5 mm mono jack
Measurement Range:	0 to 100 Vol. %
Nominal Sensor Life:	> 1, 000, 000 Vol. % h
Expected Operating Life:	< 6 years @ ambient air
Output Signal:	13 to 17 mV @ dry ambient air
Response Time $t_{90}$ :	< 12 s
Drift:	< 1% volume O <sub>2</sub> / month @ air
Operating Temperature:	0 to 40°C
Pressure Range:	750 to 1250 hPa
Linearity Error:	≤ 2% @ 100% O <sub>2</sub> applied for 5 min
Zero Offset Voltage:	≤ 200 μV in 100% N <sub>2</sub> , applied for 5 min
Repeatability:	± 1 % volume O <sub>2</sub> @ 100% O <sub>2</sub> , applied for 5 min
Influence of Humidity:	-0.03% rel. O <sub>2</sub> reading / % RH
Recommended Load Resistor:	> 10 kOhm
Temperature Compensation:	NTC
Interferences:	according to DIN EN 12598 and ISO 7767

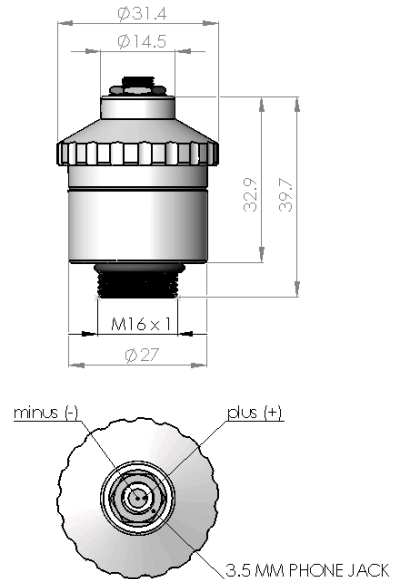

### Storage Conditions

Temperature Range:	recommended: 5 to 30°C maximum: - 20 to 50°C
Humidity:	up to 100% RH
Shelf Life:	< 6 months
Weight:	approximately 26 g
Material in contact with media:	PA, PPS, PTFE, stainless steel
Warranty Period:	12 months
Housing Colour:	white