

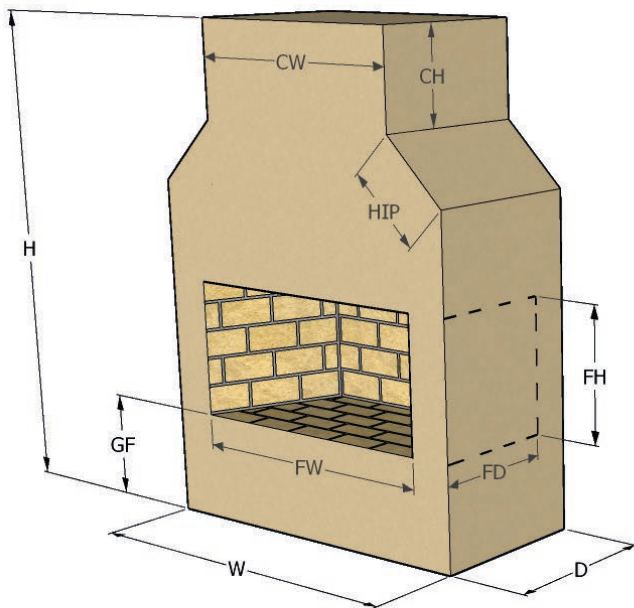

FIREPLACE

Technical Spec Sheet

HIPPED



SQUARED

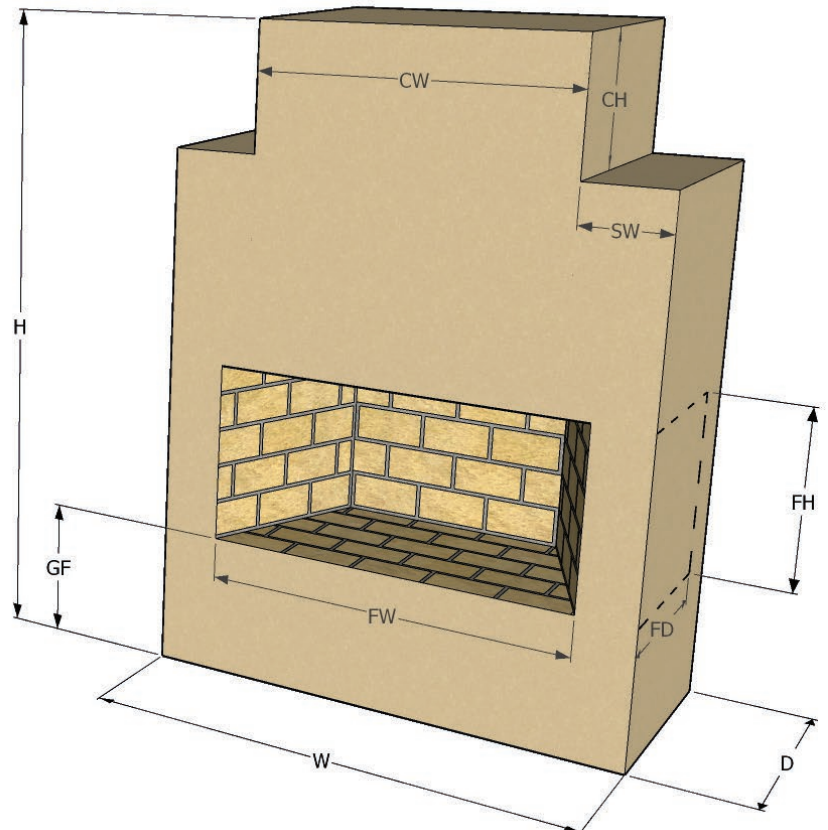

Mailing/Billing Address:
PO Box 312
Kidron, OH 44636

330.621.3657 • RoundGroveProducts.com
scott.widmer@roundgroveproducts.com

Factory Address:
12980 Arnold Road
Dalton, OH 44618

FIREPLACE

Material Specs

The fireplace is constructed of 18 gage galvanized U-channel frame (3551A-G70 and 3551A-G10) with top and bottom plates. The steel is fastened with Philips #2 Zinc Plated Wafer Head Self Drilling Screw. Steel studs are spaced between 12" and 16" on center throughout each wall frame. The firebox is structurally supported by a plinth made of 18 gage galvanized u-channel framing and ½" thick high density structural magnesium oxide board; class A1 fire rated CE-EN12467 & EN13501; ½" x 48" x 96" as a backer board behind the firebrick. Buff Fire Brick, manufactured to meet ASTM C 27 (Low Duty) and C 1261. Full firebrick is laid on the floor of the firebox and split firebrick are laid on the walls of the firebox. The grout between the joints is refractory mix #50 Gray, FXC240, high-strength, polymer-proprietary additive enhanced, lightweight dry cement mix. The hood inside the firebox is made from 18 gage G70 galvanized sheet metal.

The firebox exhausts to the chimney through a transitional smoke chamber made of 18 gage galvanized steel. The smoke chamber exhausts through a double-wall flue liner up to 14" inside diameter depending on the overall height. All double-wall flue liners have 2" clearance to combustibles. The double-wall pipe is topped by a spark arrester/ chimney cap.

Brick Oven is insulated with Roxul ComfortBatt mineral wool insulation.

The exterior of the fireplace is covered with a ½" magnesium oxide board and wrapped with fiberglass reinforcement, then scratch-coated with ¼" to ⅜" mix of 2-parts Type M mortar to 3-parts mason sand.

Round Grove Products recommends the chimney terminates at least 24" higher than any structure within a 10' radius.

Every site has different soil conditions. As a general rule of thumb, Round Grove Products recommends setting our fireplaces and brick ovens on a minimum 6" slab. Some conditions may require Sonotube piers on the four corners; other conditions may require a deeper footer depending on frost line or the weight of finish overlay.

Municipal codes may vary and Round Grove Products is not liable for compliance to local building code ordinances. Check with your local building code authority before beginning your project.