



Dear Reader:

For those who are not familiar with masonry heaters this guide will provide you with some history about these extraordinary fireplaces, the common sense principles of radiant masonry heating and the unique features that make them such efficient and clean burning heaters.

This guide will also explain why a Temp-Cast masonry heater has an extremely low environmental impact when compared to other wood burners and conventional heating systems. We also demonstrate that masonry heaters are easily the safest of all solid fuel appliances and how they can enhance a healthy life style.

If your building plans already include a Temp-Cast fireplace, the guide will give you the details necessary to accurately plan the installation. If you are still undecided, it will help you to understand the construction and installation requirements.

Our fully modularized core kit permits complete freedom of design to finish your heater with whatever material best complements your décor and style of home. Your choices may include indigenous rock, stone, tile or combinations of these, allowing you to create a unique fireplace, which will be the focal point of your home.

The task of selling masonry stoves in North America is essentially one of education. With no masonry stove tradition here, virtually all our marketing efforts go to educating the consumer, which has become easier with increased awareness and focus on green technologies. Invariably, we find that when consumers are fully informed, they also become masonry-heating converts.

The masonry heater industry continues to grow, gaining acceptance with a larger segment of consumers every year. Temp-Cast has been a leader in this industry for almost 35 years, which makes us one of the most experienced in North America, with thousands of heaters in daily use. We have been tested for safety, performance & emissions over this time, in many jurisdictions, and we are proud of our consistently excellent performance and low environmental impact.

We hope that you find this guide helpful and informative, and we would be pleased to review and comment on your plans. If you find that you need additional information, please visit our website at www.tempcast.com, email us at staywarm@tempcast.com or call us at (651) 303-9841. (You can also write to us at Temp-Cast LLC, 8820 Grey Cloud Island Drive South, St. Paul Park, MN 55071.)

Sincerely,

A handwritten signature in black ink, appearing to read "Patrick Sieben", with a long, sweeping underline.

Patrick Sieben

President

Section 1. <u>MASONRY HEATING</u>	PAGE
The Birth of the Masonry Stove	3
Radiant Thermal Mass Heating	3
Combustion and Heating Efficiency	4
Heating Performance	5
Energy Efficient Homes	5
Solar Compatibility	5
Back-up Heating	5
Towards More Independence	5
Section 2. <u>ENVIRONMENTAL ISSUES</u>	
Emissions, PM 10	7
Wood - A Clean, Renewable Fuel	8
What Price Do We Pay for Convenience	8
Health, Comfort & Quality of Life	9
Safety	9
Section 3. <u>TEMP-CAST FIREPLACES</u>	
The Fire	10
Modular Contraflow Design	10
Core Assembly & Facing Materials	11
Design Flexibility	11
Locating the Fireplace	11
Standard, Corner, Bake-Oven, & See-Thru Models	12
Temp-Cast Doors	13
Other Options & Accessories (Doors, Dampers)	13
Hot Water Options	14
Cost Comparisons	14
Warranty Info	14
Section 4. <u>CONSTRUCTION CONSIDERATIONS</u>	
General	15
Chimney Systems	15
Chimney Draft	15
Exterior Chimneys	15
Fireplace Openings & Flue Size	16
Negative Pressure & Depressurization	16
Stack Effect	16
Replacement Air	17
Footings, Foundations & Floor Pads	17
Combustion Air Supply	17
Double-Stacked Fireplaces	18
Chimneys for Double-Stacked Fireplaces	18
Ash Removal	18
Clearances & Building Codes	19
Wood Storage	20
Planning Summary	20
Additional Sources of Information	20
Involving Professionals	20
Section 5. <u>INSTALLATION NOTES & PLAN DRAWINGS</u>	
Notes to Drawings	21
Single Rear Chimney & Corner Fireplace Plan	22
Single Side Chimney & Double Rear Chimney Plan	23
See-Through & Standard with Double Side Chimneys	24

Section 1 - Masonry Heating

The Birth of the Masonry Stove

From the tenth century onward, homes throughout Europe were predominantly heated with wood. Wood was also in widespread demand as a building material during this era.

By the 15th century, wood shortages had begun to develop and European governments of the day realized an energy crisis was upon them. In the following two hundred years, efforts were made to conserve wood, with little success. However, as the energy crisis worsened into the 17th and 18th centuries, kings in Prussia, Sweden, Norway & Denmark ordered their craftsmen and architects to produce better wood stove designs. This concerted effort produced radically new heat-storing masonry stove designs, which showed enormous improvement in efficiency and corresponding wood conservation.

Many of these designs survived and are still in use today in countries such as Sweden, Austria, Finland and Germany. Temp-Cast fireplaces closely follow original Scandinavian designs, which were later refined and used extensively in Finland.

Masonry stoves are still in widespread use throughout northern Europe and are highly regarded for their excellent heating abilities, safety features and environmentally positive aspects.

Notably, the Finnish government encourages the use of masonry heaters through tax incentives, to reduce the use of natural gas, oil and electricity. The result is that a large percentage of the new homes

built each year in Finland are heated with a masonry stove.

An equally long tradition of masonry heating has evolved in Germany, Austria and Switzerland, with the "kachelofen" or tile stove as the predominant style. These heaters are so highly prized that German stove masons custom build thousands of masonry heaters each year, even though customers must often wait a year or more.

In North America, our heating traditions unfolded differently, where an abundance of fossil fuels led to their widespread use in heating. As a result, gas, oil and electricity still have the lions share of the residential heating market and thousands of marketing people spend millions of dollars to keep it that way.

During the North American energy crisis of the '70s, many people turned to metal stoves to cut their heating bills. Environmental and economic concerns of the last decade have forced a critical look at better wood-heating devices.

Radiant Thermal Mass Heating

Masonry heaters work by radiating the energy stored in their masonry mass. Heaters like the Temp-Cast 2000 are simply heat storage banks. A short, hot fire heats the masonry mass, which stores and radiates it back to the space slowly and evenly for many hours. This creates a very gentle heater, with unobtrusive warmth.

Radiant heat from a masonry heater is very similar to the radiant heat from the sun. Just as the sun warms the earth, the

masonry stove heats by warming solid objects in the home, such as walls, floors, furniture and people.

And like a miniature sun in the centre of your home, this radiant energy from the heater does not directly heat the air that it travels through, which has some important health benefits, detailed in Section 2.

Fig 1

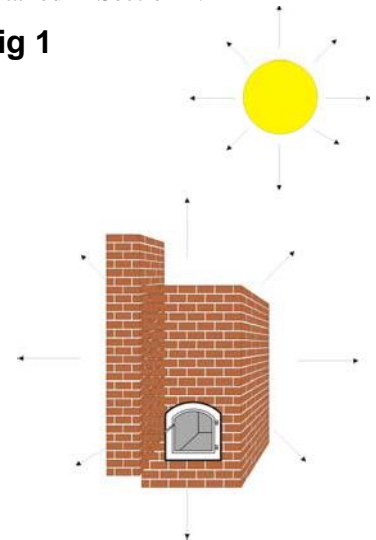

From the first time the fireplace is fired, the heating cycle is very even, only slightly cooler in the morning than in the previous evening. This is quite unlike traditional wood heating systems, which create a very hot space around them, cool considerably during the night and then super-heat the area when re-loaded in the morning. In addition, radiant masonry heating produces "all over" warmth, as the solid objects in the area are warmed and then radiate the warmth to you.

Combustion and Heating Efficiency

The *combustion efficiency* of a heater measures its ability to burn a given fuel completely and without pollutants, thereby producing heat energy.

When a piece of wood is burned, about 30% of the heat generated is supplied by the solids in the wood and 70% is contained in the gases released as the wood is heated. If the gases are not fully burned, they escape as wasted heat and smoke (air pollution) and often condense on a cold chimney as creosote, the fuel for chimney fires. Many of these gases do not burn until temperatures reach 1100 degrees F. (593 deg.C)

The requirements for good combustion are a design that allows the firebox temperatures to build sufficiently, and ample oxygen in a turbulent environment.

Heating efficiency shows how rapidly the heat produced by the fire is transferred to the room. It does not, however, measure how comfortable the room will be, only how quickly the heat is delivered. **A combination of high combustion efficiency and moderate heat transfer efficiency is the ideal in any wood burner.**

Metal stoves and wood furnaces typically have relatively *lower* combustion efficiencies and relatively *higher* heat transfer efficiencies than masonry heaters. Metal transmits heat very well, in fact within minutes of the fire being lit. Similarly, a wood furnace heats the air instantly and immediately distributes this hot air to the home. This makes for a very responsive heater, which is able to throw heat into a space

very quickly. However, this fast response comes with two critical drawbacks.

Firstly, it becomes very difficult to regulate the heat output so that it is comfortable.

If the heat output (*heat transfer*) is controlled by restricting the air supply, *combustion efficiency* drops off drastically, causing a smoky fire, huge amounts of air pollution and probably creosote deposits. If the air supply is not restricted, combustion efficiency improves but the room becomes too hot and dry, which also has an adverse effect on the health of the occupants. This clearly demonstrates that high heat transfer efficiency is not necessarily a desirable quality of a wood heater.

Secondly, combustion efficiencies of metal stoves and

becomes too hot and the unit is severely "overfired". They are usually not comfortable to be around when burned at over 400 degrees F. (204 deg. C), due to their high heat transfer efficiency.

Contrast this with masonry heaters, with thick masonry walls, which are slow to release their heat and therefore have *moderate* heat transfer efficiency.

This moderate heat transfer makes the masonry heater cherished for its gentle heating nature. Moderate heat transfer also allows the firebox temperatures to reach 1500 degrees F. (815 deg. C) or higher, creating very high combustion efficiency, while the exterior is still only warm to the touch.

Testing in Finland has

Fig 2

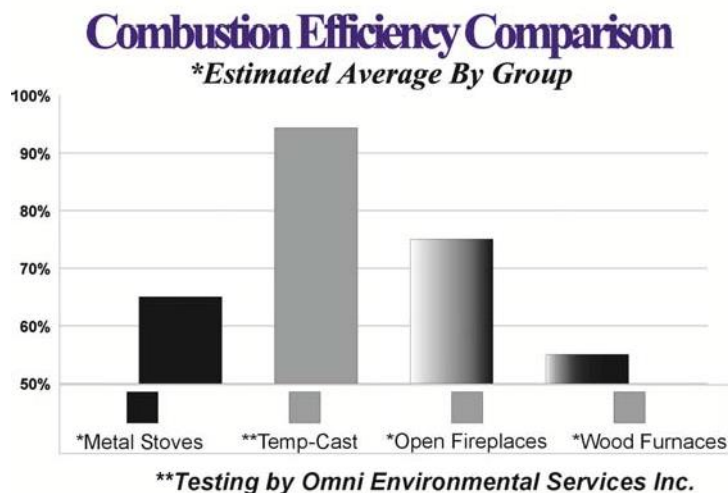

furnaces are comparatively low, because the heat is given off too quickly and the temperature of the fire cannot build to the point where the gases are fully burned. Most metal stoves and furnaces cannot be burned safely over 900 degrees F. (482 deg. C) because the metal

shown that masonry heaters typically attain combustion efficiencies of 88 to 91%. Independent laboratory testing of the Temp-Cast heater in North America demonstrated a combustion efficiency of 94.4% and heat transfer efficiency of 65.4%. When the principles

involved are carefully studied, it becomes clear that *maximum* heat storage and *moderate* heat transfer produces the optimum in clean burning and gentle heating performance.

Fig 3

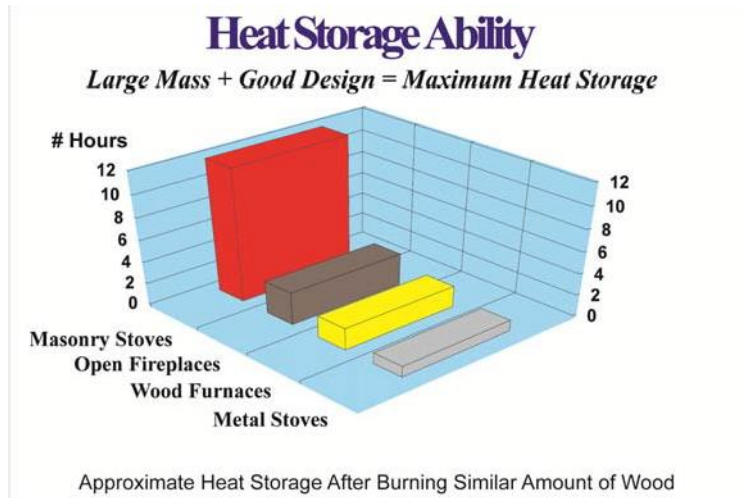

Many new homes are built super-insulated and super-tight for optimum energy efficiency, requiring very few air changes per hour and comparatively little Btu/hr. Temp-Cast heaters are particularly well-suited to these new home building techniques,

custom-designed for a specific climatic location, and virtually no air leakage. Air changes in these homes are typically 1/3 to 1/4 air changes/hour. In super-insulated homes like these, many conventional heating systems (particularly woodstoves) overheat the home because heat transfer efficiency is too high. (Refer to the previous section on Combustion & Heating Efficiency.)

With a Temp-Cast masonry heater, the heat transfer efficiency is much lower than other systems, so that the heat is generated at a lower rate over a longer period of time. The heating curve of a Temp-Cast heater is relatively flat (being slow to warm up), stays level for a long time (thermal mass retains the heat) & then drops off very slowly (energy is released to its surroundings at a slower rate). In effect, the radiant energy from the thermal mass is self-regulating - heat is radiated slowly as the objects in the living space require it. In this way, it is the ideal heating system for energy efficient

Heating Performance

Temp-Cast masonry heaters can serve as the primary heater in a well-insulated modern home of up to 2000 sq. ft (185 m²), when located in the middle of an open plan living space.

On each firing of 50 lbs (22kg) of wood, a Temp-Cast 2000 fireplace can deliver up to 250,000 BTUs (73.2kw) of radiant heat. Total heat output is controlled by the *amount* of fuel burned, while the rate at which heat is delivered remains relatively constant. (2 firings per day are typical in the colder climates of North America - see Fig 4 .)

By comparison, forced air systems must have a substantially higher BTU rating to heat the same space, due to the "wind chill" effect of moving air. Energy Efficient Homes

including earth-sheltered homes, ICFs (Insulated Concrete Forms) & SIPS (Structural Insulated Panels).

Homes built with these systems typically have very high R values,

Fig 4

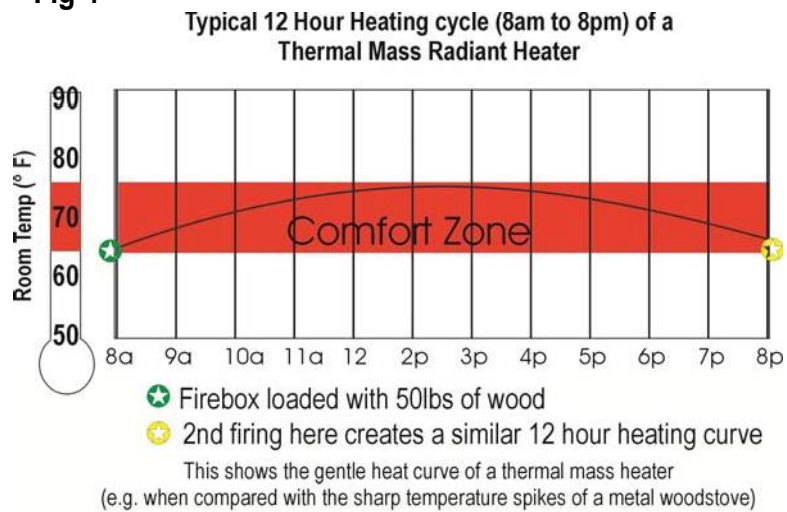

Note: temperatures shown will vary!

homes.

Solar Compatibility

Masonry heaters are also the ideal complement to passive solar heating. The masonry stove mass can also add to the heat storage total of the building. Both are non-polluting, energy efficient and economical heat systems.

Backup Heating

We suggest that you provide back-up heating for your Temp-Cast fireplace if it is used as your primary heater. For those periods when your home is unattended for 3 or more days, a suitable back-up heating system should be considered.

Towards More Independence

Alternate fuels such as solar and wood have always held an

appeal for some people, who want to retain a small measure of independence from the gas and electrical utilities and the international oil conglomerates.

Peace of mind and a sense of stewardship comes from knowing that you can harvest a renewable energy source locally and burn it cleanly, while heating your home efficiently.

There is also some satisfaction in not being dependent on uncertain reserves of oil, gas and electricity, or on the decisions made in the boardrooms of those who control these energy sources.

"I am not prejudiced against electricity, but power in my area fails several times each winter. If I were dependent on it for fresh air or heat, I would be out of luck, sometimes for days. To me, one of the main reasons to have solar heat or wood heat is that it lets me, in some small way, function more

independently. Then when the power failure occurs, I can still cope. The water arrives by gravity feed. The heat comes from sun and wood. I have no problem with indoor pollution because the fire, that engine of air movement, dries the place out a bit, and keeps fresh air moving. My goal is to use a modest amount of wood each winter - say one to three cords, an amount I could cut with a chain saw if necessary - and let the house breathe. I might have insulated so that a candle and three cats kept the place warm. But I am glad to have a fire, and to know that it is winter. Ideally, I believe the right way to heat such a dwelling is with the sun plus a masonry stove: safe, efficient, attractive, comfortable to live with, and not terribly demanding to operate." (Ref. David Lyle, The Book of Masonry Stoves)

Section Summary

- *Masonry heating has a long history of reliable & durable heating performance.*
- *Radiant heating is one of the most comfortable and efficient heating systems.*
- *Masonry heaters have unsurpassed combustion efficiency & are acceptable in areas where other stoves & fireplaces are banned.*
- *A masonry heater operates independently of public utility services.*
- *A Temp-Cast masonry heater is the ideal heater for super-insulated, tight homes.*
- *Masonry heaters usually require back-up heat systems.*

Section 2 - Environmental Issues

Emissions - "If You Love This Planet..."

"Tomorrow's consumer will be concerned not only with how much energy his house consumes, but also how much environmental impact his particular form of energy has." (Ref. Masonry Heater Association News, Vol. 5, #2, reporting on articles in "Environmental Building News")

Incomplete combustion of wood creates biologically harmful "particulate" emissions, visible as smoke. In the United States, the Environmental Protection Agency and individual states enforce the most stringent regulations on wood smoke emissions in the world. In many states, wood stoves and open fireplaces are being restricted or completely banned due to their inherent poor combustion and excessive emissions.

Not many would argue that we cannot continue to pollute the oceans and rivers and the air we breathe and hope to live long and healthy lives. Ultimately, improving air quality and other essential elements of our environment will be a "grass roots" movement by people around the world doing a little to create a large impact.

The combustion air delivery design of a Temp-Cast fireplace, in combination with a "top-down" burning technique, optimizes combustion efficiency. This permits more complete combustion during the early stages of a fire, as the wood gases burn above the fuel as soon as they are released. The top down burn assists this, with the kindling placed on top of the main fuel load igniting

Fig 5

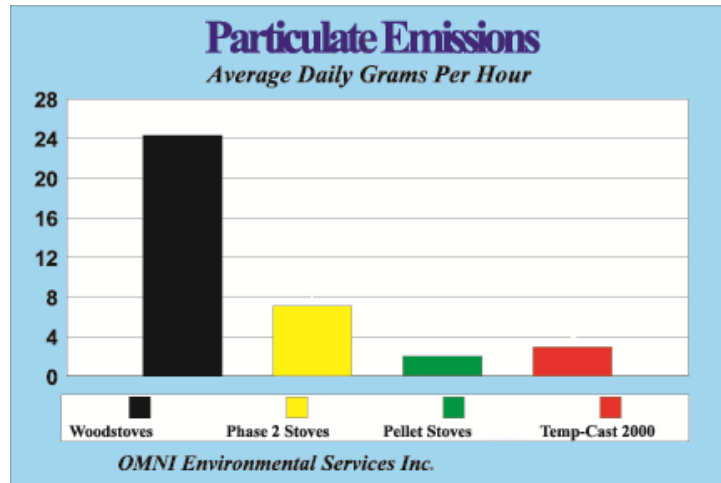

quickly and promoting rapid gas combustion.

These innovations ensure that the vast majority of environmentally harmful gases, compounds and tars are burned in the firebox, creating heat, not pollution. The Temp-Cast 2000 fireplace, and other masonry stoves, have been tested for emissions, demonstrating that they are among the cleanest burning wood stoves in existence.

Heating your home or cottage with a Temp-Cast masonry heater is a responsible environmental decision that you can feel good about - for not adding to the air pollution problem, and for using a renewable fuel that is intimately part of the natural ecology.

PM-10

Recently, legislators and consumers have become increasingly concerned with PM-10 wood smoke emissions - those particles which are 10 microns or less in size, and which can be easily absorbed into the bloodstream through the lungs. Researchers have

therefore been testing more rigorously for these specific emissions in the last few years.

Masonry heaters as a group have been shown in field tests to emit an average of 2.8 gm/kg of PM-10 emissions, compared with an average of 7.3 gm/kg for the best Phase II woodstoves.

As a result of the field testing done on masonry heaters, the EPA have included them in a follow-up report on wood stove emissions. The B.A.C.M. document (Best Available Control Measures) includes masonry heaters as acceptable due to their exceptional clean burning technology. This document is for various levels of government to reference when they are implementing state and local air quality regulations.

Wood - A Clean, Renewable "Green" Fuel

Wood, if properly burned, is a very "clean" fuel, comprised of 99% combustible solids and gases. The other 1% is non-combustible ash, which can be recycled into the garden. In

addition, *efficient* wood-burning does not add to global warming or acid rain, since burning releases about the same amount of carbon monoxide, carbon dioxide and methane as the natural decomposition of wood on the forest floor.

Although wood is one of few truly "renewable" fuels, it is vastly under utilized in North America.

Many countries encourage wood use for home heating and have comprehensive forest management plans which take into account the value of wood as a heating fuel. It is comparatively inexpensive to grow, manage, harvest and handle.

Properly managed, an industry surrounding wood use as a house heating fuel would create thousands of local jobs, reduce our dependence on other fuels, and be beneficial to our planet.

What Price Do We Pay for Convenience?

Non-renewable fossil fuels, although convenient for consumers, are generally difficult and expensive to obtain and environmentally harmful to produce, transport and use.

Society is becoming increasingly concerned with the negative environmental impact of fossil fuel usage around the world. The damage by oil spills worldwide will have lasting serious effects on the oceans and sea life. Natural gas pipelines have been pushed through sensitive arctic tundra, disrupting wildlife and exposing these areas to a potential disaster. The extensive damage to the ozone layer, global warming, and acid rain are all legacies of our insatiable appetite for more energy to

operate our machines and warm our homes.

Convenience and this same craving for energy has allowed electrical production to flourish, again with some negative ecological impact. High-power lines are suspected of causing illnesses, dams divert water from fish spawning grounds and nuclear plants are labeled environmental "time bombs".

Although expedient, heating our homes with gas, oil or nuclear-fueled electricity may be environmentally questionable. And it may be unnecessary, with alternatives such as solar heating and masonry heating now available. We must ask ourselves what environmental price our children will pay for the convenience we demand today.

Homes heated with a radiant masonry heater are relatively quiet and have a cozy warmth which you may only notice when you step outside. Because the air is not being directly heated by the fireplace, as it is in a forced air system, it is cooler and seems fresher, a welcome change to allergy sufferers.

By contrast, metal stoves and forced-air furnaces tend to "fry" the dust in household air, due to their higher surface and burner temperatures, causing an unpleasant smell and dry air. European authorities are now studying the adverse biological effects of "fried" household dust.

Energy Content of Wood

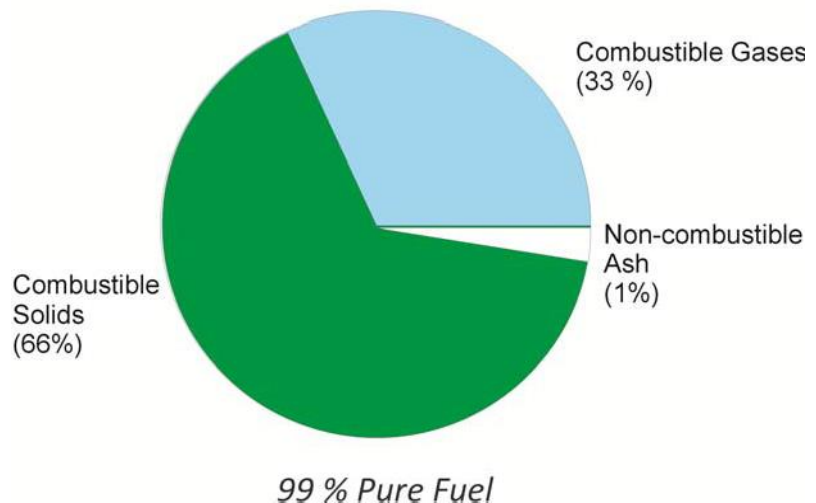

Health, Comfort & Quality of Life

"Finnish fireplaces produce gentle, long term radiant heat that directly affects the indoor environment in a profound way." (Ref. Albert Barden & Heikki Hyytiainen, Finnish Fireplaces - Heart of the Home)

"It should also be noted that the whole concept of airtight house construction and its accompanying problems of indoor pollution is healthily challenged by masonry wood heating. With masonry heaters we are not trying to heat the room air by forced convection from some remote, dusty, central heating system. We are instead heating solid materials and people by direct radiation. Such a system creates warm, solid surfaces and fresh, clean air." (Ref. Albert Barden & Heikki Hyytiainen, Finnish Fireplaces - Heart of the Home)

Since a masonry heater does not superheat the air, currents and drafts caused by the hot air/cool air cycle are reduced, and with them, the "indoor weather". In addition, there is no powerful fan pushing the air around, contributing to this moving air and "wind-chill".

Another subtle benefit of this type of heating is the stimulating effect of slight variations in heating from room to room. (*Slight* is the important word - large differences in heating from room to room are a

little too stimulating for most people.)

"The user of a fireplace comes to understand that fire, like the sun, is a life-sustaining and renewing force, that the real purpose of a fireplace is to renew the energy of those who gather around it." (Ref. Albert Barden & Heikki Hyytiainen, Finnish Fireplaces - Heart of the Home)

Safety

There is no safer wood-burning heater than a properly constructed masonry stove. It is only fired for a few hours a day while you can watch it, and never at night when you sleep.

The masonry exterior of the heater, except for the metal & glass of the firebox doors, is generally safe to touch. The hottest points, front and rear just above the firebox, typically do not get hot enough to burn bare skin. In fact, it is quite safe and comfortable to sit with your back to the sides and rear of the masonry facade to soak up warmth. Many old European stoves had a sleeping platform built onto the top of the heater

and some people today incorporate a heated sitting nook or bench into their designs.

Chimney fires are a major concern in North America, causing house fires which result in needless deaths and destroyed homes.

Chimney fires are a serious problem with metal stoves and wood furnaces, due to typically low operating temperatures and resulting low combustion efficiency. This allows unburned gases to form tars and compounds in the smoke, which then condense in the chimney system, forming creosote, the fuel for a chimney fire.

This problem is virtually eliminated with a masonry stove, mainly due to the heat storage ability inherent in their designs. The masonry mass and large heat storage allows them to be operated *comfortably* at high temperatures, which creates consistently high combustion efficiency. These two features, which are unique to masonry stoves, ensure that all combustible gases are burned in the heater, producing more heat, not creosote.

Section Summary

- *Wood smoke emissions contribute to poor air quality & will face ever-increasing regulation.*
- *A Temp-Cast wood heater is one of the cleanest-burning products available.*
- *Masonry heaters are unsurpassed in terms of safety & indoor air quality.*
- *Temp-Cast heaters are acceptable in many areas that have restricted or banned other types of stoves or fireplaces.*
- *Wood as fuel is inherently clean - in a masonry heater it is a clean and renewable resource.*

Section 3 - Temp-Cast Fireplaces

The Fire

Fire has always fascinated man and been central to his life. Our ancestors simultaneously worshipped, revered, and feared fire, and were bound by rituals and myths concerning its use. Modern man is still dependent on fire in many forms.

*"In our economy of abundance, fire is at the heart of the magic - in industrial plants, in automobiles, in our homes. A fuel cutoff sends shocks through the entire world economy. Whole societies become uneasy, and there is a search for relief, for new ways to feed the flame and keep it burning." (Ref. David Lyle, *The Book of Masonry Stoves*)*

One of the most distinctive features of a Temp-Cast fireplace is the outstanding fire-viewing. When the fire is lit, it catches quickly and burns fiercely, creating a spectacular show. If a bake oven is incorporated, you can see the burning gases accelerating through the gas slot, creating an exciting "spark shower" and adding to your enjoyment of the fire.

An air-wash system feeds the combustion air across the glass of the firedoors to maintain a clear view of the fire. The arched-door option also pre-heats the combustion air for increased efficiency, which is especially important when an outside air supply is required to bring in cold exterior air. (See Fig. 7)

The Modular Contraflow Design

Temp-Cast fireplaces were created from early Finnish and Swedish designs in which the fire burns in a central firebox,

Fig. 7

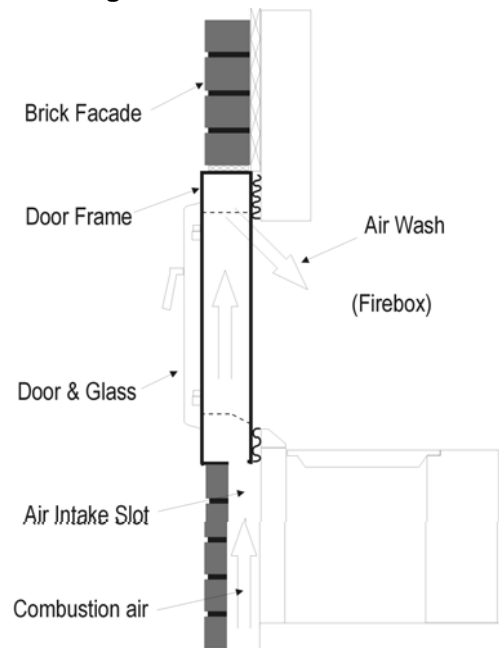

and up through a gas slot to a secondary combustion chamber. At the top, the fire is split into two streams, which travel down inside the heat exchange channels built into either side. This opposing flow of fire and gases up the centre and down the sides is usually described as the "contraflow" action of the fireplace.

The contraflow or "Finnish fireplace" design is generally accepted as the simplest and one of the most efficient of all masonry heater designs.

Finnish fireplaces and other masonry heaters can be hand-built by specially trained "heater" masons. However, each custom built unit may be slightly different

than the last, and relies completely on the skill of the mason and his attention to numerous critical details. If the fireplace is incorrectly or carelessly built it may not work properly and worse still, it may be unsafe.

Temp-Cast fireplaces were carefully designed and tested for optimum efficiency, ease of assembly and maximum safety. Once the design was proven and tested in the field, it was modularized to simplify the assembly and allow it to be reproduced in a controlled factory setting.

The modules are manufactured from a castable refractory material. They have a unique interlocking feature, so that one piece is precisely keyed to fit the next one. This allows the kit to be quickly and accurately erected and ensures that the completed core is structurally stable and independent of the facing material. The interlocking feature also ensures that the parts stay firmly locked in position during the constant expanding & contracting which occurs in a masonry heater.

The modules themselves are precisely dimensioned, which will produce a level, plumb and square finished core. This, in turn, simplifies the addition of the facing masonry and thereby produce a safe, effective and professional-looking product.

Meticulous attention to quality control ensures that each fireplace shipped will perform to a predictable standard.

Core Assembly & Facing Materials

Temp-Cast fireplaces incorporate a "floating firebox" design, which isolates the heater core from the external masonry facing. Considerable expansion and contraction takes place in the heater, and this design prevents the movement from affecting the finished exterior.

The fireplace core modules are assembled on a reinforced concrete pad, supported on a suitable block foundation and footing. A flue connection is cut by the installer for the chosen chimney and location. A mason then erects the selected facade, which serves as the decorative finish and the necessary additional thermal mass.

Suitable facades must be of non-combustible materials, such as solid or filled **fired-clay bricks, natural stone, fieldstone, soapstone, and river rocks**. Brick can also be covered with tile, marble or stucco. We recommend a façade thickness of 4", including back-fill – this is the minimum thickness for safety clearances and it is also the ideal thickness for optimum heating performance. *(It is possible to use a façade of up to 5" thick, but this will make the heater less responsive and may encourage over-firing to bring the surface up to a comfortable heating temperature.)*

The facade can be carried to the ceiling if desired, but provision must be made to allow the heat from the top of the fireplace to be vented. This is

easily done by providing grillwork or air spaces just below ceiling level.

WE DO NOT RECOMMEND USING CONCRETE BLOCKS FOR FACING THE HEATER.

Design Flexibility

The final appearance of the heater is limited only by your imagination and the skill of your mason. Brickwork can extend into wood storage boxes, shelving, benches and nooks, mantels, and cathedral arches. The ideal location for the heater is freestanding in the middle of a space. It can also be part of one or more interior walls. Corner units extend this flexibility further, by forming part of an interior corner wall, or standing freely to suggest a corner divider between several rooms or areas. Chimneys can be attached on the sides or back of the fireplace, allowing additional design flexibility.

With planning and imagination, your Temp-Cast will be a unique piece of functional art.

Locating The Fireplace

Whether the fireplace is to be used as a decorative fireplace, an occasional zone heater, or a primary heat source, its location must be carefully considered.

A central location in the living space is the ideal position for a masonry heater to optimize heating performance. An open floor plan design will also

maximize the heating ability of the Temp-Cast - it directly heats what it can "see", so if all 5 surfaces (4 sides and the top) are exposed to the space, they will contribute effectively to the overall heating ability of the unit. *Whatever the chosen placement of the heater in the living space, it is critical to ensure that the heater & chimney are completely within the warm envelope of the home. Refer also to Section 4.*

The maximum benefit and enjoyment can be derived from the fireplace if it is fully integrated into the home and the family. Aesthetic appeal is important, but also give equal consideration to family traffic patterns and lifestyles.

Place the fireplace so that it is visible from as many parts of the living area as possible. If it divides living room and kitchen, a bake oven on the kitchen side gives form and function to that side of the fireplace. Located in an open-plan corner, three or more rooms can be warmed by its exposed surfaces. The fireplace walls and the chimney can act as room dividers, providing walls and heat simultaneously.

Ideally, a masonry heater should be treated as a very important part of the home, with a view that it will be a part of the every day life of the family and provide a focus for daily routines. Hopefully, the family will gather around it each evening to talk or read or to just enjoy the fire

Standard Models

The Temp-Cast 2000 standard fireplace core is 36" (914mm) wide by 22.5" (571mm) deep by 77" (1955mm) high, not including the masonry facing. Its rectangular footprint makes it most suitable for installations along a wall or in the centre of a room. (See Fig. 8) The 2000 is also available with a Corner option, Bake Oven option, or See-Through option or a combination of options. (Note: dimensions shown are accurate to within 1/4")

is suitable for installation in an inside corner, or to form the walls of an inside corner, or free standing in the centre of a room. It can be oriented so that the fire is visible from various parts of the room, which may not be possible with a standard fireplace.

The chimney can be connected to the back of the core, or to any of the four angled corner surfaces, giving added flexibility.

Bake Ovens

Temp-Cast 2000 standard fireplaces, see-through and corner fireplaces are available with a bake oven option. The oven can be installed on the front of the heater or on the back side, allowing the fireplace to be a divider between living room and kitchen.

The bake oven is installed in the secondary combustion chamber. After the fire is out, breads, pizza, and pastries can be baked in the remaining heat. If additional heat for baking is needed, a fire can first be set in the bake oven itself to increase the temperature. An

optional *Bake Oven Trim Plate* can be installed before the facing is applied, to permit a neater finish around the bake oven door. The Trim Plate hides the core so that the mason does not need to bring masonry

work too close to the bake oven door frame. (Refer to Fig 8)

Another option is to place a cooking grill in the firebox of a Standard Model after the fire is out. There is sufficient residual heat here for all your baking needs.

See-Through Fireplaces

Often, a fireplace will divide two areas of a living room or a dining room, when fire-viewing from both sides is desired. The Temp-Cast See-Through fireplace allows this by offering a second set of fire doors on the back of the unit. Both doors are functional and offer a clear view of the fire.

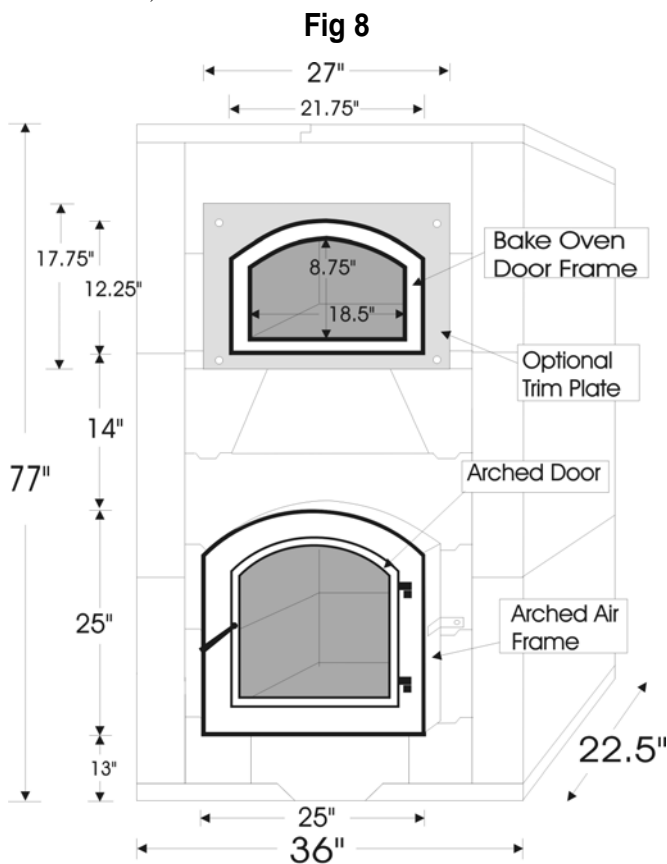

Temp-Cast 2000 Standard Fireplace (with Arched Door & Bake Oven options)

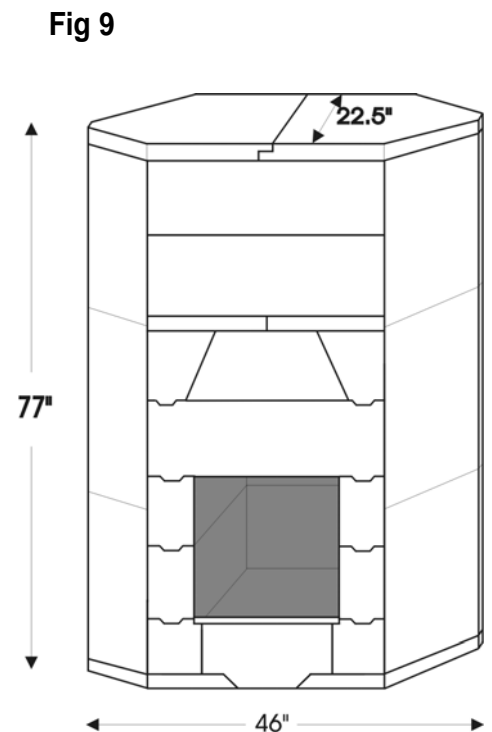

Temp-Cast 2000 (Standard Corner Fireplace)

Corner Models

A Corner Model Temp-Cast 2000 core is 46" (1168mm) wide X 22.5" (571mm) deep X 77" (1955mm) high, without the facing material. (See Fig. 9). It

Temp-Cast Doors

Two door systems are offered, an arched door with steel air frame (Fig 10) and a rectangular door with steel air deflector (Fig 11). Doors are constructed of high-quality cast-iron, fitted with an air-tight gasket and can be ordered with 24 K gold plating. Both systems incorporate air-washes for clear and unobstructed views of the fire. The fire-viewing area is approximately 18" wide (460mm) X 16" high (405mm).

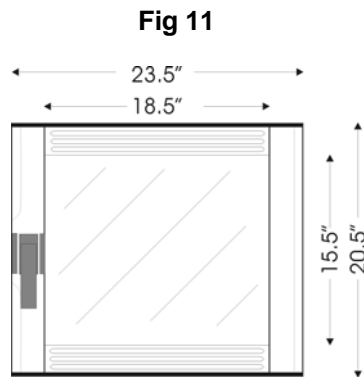
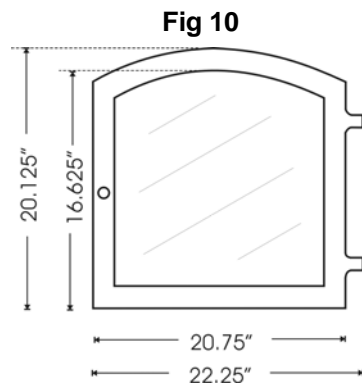

Other Options & Accessories

Temp-Cast fireplaces are offered with several options to maximize efficiency and appearance.

Where exterior combustion air is required, **electric fresh air dampers** increase efficiency by allowing fresh air into the home only during actual combustion.

Insulating boards under the fireplace core minimize heat loss through the concrete pad or basement floor, for increased overall efficiency.

A **chimney damper** is recommended in all installations to maximize the heat-storing ability of the fireplace and to ensure strong chimney draft at start-up.

The most effective damper for a masonry and flue tile chimney is a **"roof-top" damper**, installed at the very top of the chimney flue and controlled by a stainless steel cable (see Fig 12).

The cable is routed down through the chimney and is attached to a bracket in a convenient location near the heater, out of the reach of small children. Its main advantage is that it traps warm air in the entire length of the chimney, enabling better draft at start-up. It also keeps out rain, snow, birds and animals & prevents down-drafts caused by strong winds.

In some applications, it is possible to have an 8" (200mm) round masonry chimney (e.g. round clay flue tiles and brick facing) up to the first ceiling in a multi-floor home. A metal chimney adapter is installed on top of the last clay flue tile and an 8" (200mm) diameter factory-built stainless steel chimney continues from this point. This "hybrid" chimney allows a roof-top damper to be installed at the top of the factory-built chimney.

This 'hybrid' chimney combination is possible **only where the chimney is straight**, (ie. without any offsets) so that the cable is not obstructed. If there are offsets in the chimney, then we recommend installing a Base-exit Transition, with internal damper, and either an

approved (i.e. "listed") stainless steel liner and masonry chimney facing or a full factory-built chimney system. (An adapter on top of the transition, manufactured for the chimney being used, will be required.)

Fig 12

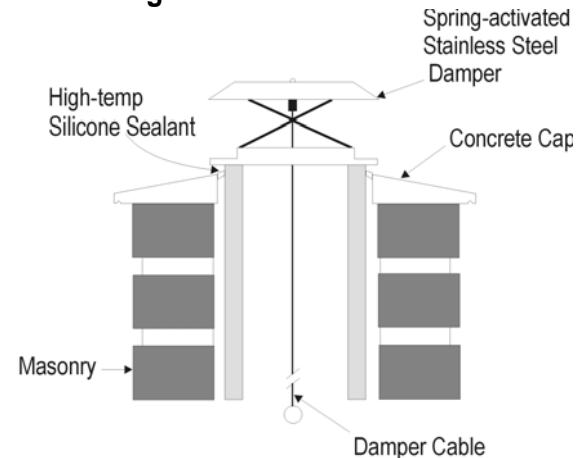

Base-exit transition dampers are used with chimneys having offsets and all factory-built metal chimneys, since a roof-top damper cannot be used with this type of chimney. This transition permits a simple installation to the heater and an easy way to install the heater with a factory-built chimney. The built-in damper helps to minimize heat loss when closed after the fire is out. (See Fig 13)

Fig 13

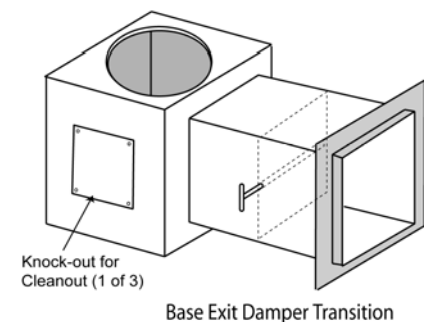

We strongly recommend a carbon monoxide alarm be used in conjunction with all chimney dampers, (installed in the same room as the heater), as an extra margin of safety in case the damper is inadvertently closed prematurely.

Additional "soot" doors may be required to ensure inspection and cleaning access to the bottom of each heat exchange channel, depending on installation requirements.

An 8"x12" aluminum ***ash cleanout door*** provides generous access to the base of the chimney for inspection and cleaning.

Finally, an optional ***air supply door*** is recommended where permitted by local building authorities. This is installed just under the fire door,

to direct air into the air intake slot under the door frame.

Hot Water Options

We have found that it is generally not feasible to use a Temp-Cast heater to produce hot water, particularly for hydronic floor heating applications. The Btu output of the heater is usually not high enough for these applications. We also do not recommend using the heater for domestic hot water production, unless your home is 'off the grid'. In this case, the hot water system must be carefully designed and engineered for safety by a competent professional, with appropriate pressure release valves and backup electric circulation pumps.

Cost Comparisons

Your Temp-Cast will require little care or maintenance

beyond regular chimney inspections and cleaning.

Annual inspection and vacuuming of the base of the heat exchange channels, and periodic replacement of the door gaskets are typically all that is required.

Wood costs the least of all fuels, and is affected least by influences beyond the local area. Compare wood costs with costs of gas, oil, propane and electricity in your area.

Warranty

Temp-Cast fireplace ***refractory parts*** carry a limited five (5) year warranty. The warranty does not extend to removal or replacement of chimneys, facades or other masonry work.

Metal parts, including doors, are warranted for 1 year. (Glass parts are not included.)

Section Summary

- ***Temp-Cast fires are truly spectacular.***
- ***Temp-Cast refractory modules are engineered for precise fit & easy assembly.***
- ***The ideal facing is a 4" thick solid masonry material such as brick or stone.***
- ***Temp-Cast design flexibility is unrivalled.***
- ***Standard, Corner, See-Through, Bake-Oven models & combinations are available. (All models can perform baking functions.)***
- ***Several options are available to enhance heater appearance and/or performance.***
- ***Both factory-built and masonry chimneys can be fitted with dampers to minimize heat loss.***
- ***The arched & rectangular door systems provide air-wash to protect the glass & metal components and provide clear fire viewing.***

Section 4 - Model 2000 Construction Considerations

General

A Temp-Cast fireplace and brick facade weighs over 6000 lbs (2720kg) in most installations, not including the chimney and concrete pad. Proper footings and foundations are required and existing supports must be inspected by a competent professional before being used.

In a new installation, a footing must be poured on undisturbed compacted soil. A concrete block foundation is then raised and a concrete pad is poured on top of the foundation to the level of the unfinished floor.

The chimney is connected at the **bottom** of the heater and is supported by the same pad which supports the heater. For this reason, the layout of heater and its chimney must be decided before the footing and foundation dimensions can be calculated.

Chimney Systems

Temp-Cast heaters require at least 18ft (5.5m) of chimney having a minimum area of at least 50 sq. inches (inside dimensions) (320 sq cm) - suitable widely available flue sizes include 8" x 12" o.d. (200mm x 300mm o.d.), 10" x 10" o.d. (255mm x 255mm o.d.) and 8" i.d. (200mm i.d.) round flues, or equivalent. Clay, refractory and stainless steel liners are suitable. Both masonry and HT (i.e. "high temperature") factory built chimneys are acceptable.

Masonry chimneys should have liners that are laid with refractory mortar and are carefully aligned so that a ledge is not formed from one liner to the next. In addition, a 1/2" (12.5mm) space must be

maintained between the liner and the brickwork, for necessary expansion. The best liners have overlapping or "ship-lap" joints.

Every chimney must have provision for cleaning, with a tight fitting door near the base.

An existing chimney should be inspected by a qualified chimney sweep and approved by the local building official.

The chimney can be connected on either side or at the back of the fireplace, as in Figure 14. You may also want a "balancing", non-functional chimney on an opposite side for aesthetics.

Chimney Draft

Chimney draft, that unseen force that we trust will cause smoke to rise up the chimney and out of the house, is the single most important aspect of good chimney design and the most overlooked.

Hot air (i.e. hot gases or smoke) rises because it is lighter than the air around it. In a chimney, this rising warm air (i.e. "draft") draws in oxygen to feed the fire. Without good draft, good combustion is impossible and smoke spillage is inevitable. Unfortunately, there are several factors which can defeat chimney draft. The three most common are *exterior chimneys*, *negative pressure* and *the stack effect*.

Exterior Chimneys

The greater the temperature difference between the air in the chimney at the stove connection and the air outside at the top of the chimney, the stronger the draft. (This is why smoke

spillage and hard starts are more common in early fall and late spring, when the temperature difference between inside and outside is the least.) In addition, the longer this temperature difference can be maintained (i.e. the taller the chimney), the greater the draft.

A tall and warm interior chimney produces the best draft, while cold exterior chimneys cause stubborn lighting, smoky fires and chronic smoke spillage. ***For this reason, we do not recommend venting our fireplaces (or any combustion appliance) to a chimney constructed outside the warm envelope of the home.*** If a chimney in an unheated space is unavoidable, then an insulated factory built chimney is best, since it will heat up faster and keep the exhaust gases warmer for a longer period of time, improving the draft. (*Using the chimney manufacturer's approved adapter, most factory built chimney systems can be connected to a Temp-Cast heater with our Base-Exit Transition Damper – see Fig 13 .*)

Fig 14

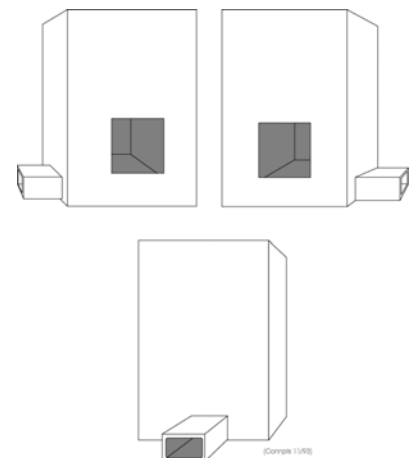

Fireplace Openings & Flue Size

Many homeowners are still very fond of the huge country fireplace - a 5 foot wide x 4 foot tall firebox. But these also require a huge chimney, through the center of the home, with a flue of at least 288 sq. inches. (*Not only a huge energy waste, but a large material expense to enclose it. Contrast this with a Temp-Cast chimney flue of about 50-60 sq. inches.*)

Negative Pressure & Depressurization

Compounding the cold chimney problem is the air-tight design of some homes, such as those using foam block and SIPs (structural insulated panels). In these homes, the air usage in the home is very tightly controlled. If make-up air is not sufficient, exhaust fans & other combustion appliances can de-pressurize the home, causing a *negative pressure condition*. In this case, air is drawn into the house from unexpected sources - down the chimneys serving the gas furnace, the fireplace, the wood stove, etc. This causes varying degrees of chimney failure. This can range from the fireplace that is difficult to start, to the wood stove that spills smoke whenever the door is opened, to the most serious, when a complete flow reversal brings smoke and gases down the chimney and into the home.

This **Flow Reversal** is potentially dangerous because it occurs most often when the burn rate is at its lowest, at the start of a fire or at the end.

In a typical metal woodstove, during the final stages of the fire, the firebox temperatures are slowly dropping. With this drop in firebox temperature comes a corresponding drop in chimney

temperatures. In masonry chimneys, this drop is gradual, but in prefabricated chimneys, the temperature drops as quickly as the stove. Eventually, chimney temperatures drop to the point where the chimney draft is stalled - smoke is no longer being drawn up the chimney and can now easily spill back into the home. This phenomenon is known as "tail-out" spillage & is believed to be a common occurrence with wood stoves, particularly in basement installations and with exterior chimneys. It is a very serious concern because it most often occurs during the night - when it is least likely to be detected & while occupants are most vulnerable - while they are sleeping.

A Temp-Cast masonry heater with an interior chimney is less likely to suffer from "tail-out" spillage. The masonry mass retains enough heat to maintain adequate chimney draft for long after the fire is out. And since there is no need to burn the Temp-Cast at night, if spillage of any kind occurred, it is more likely to be immediately noticed.

Breathing combustion gases, especially carbon monoxide, from a wood or gas appliance, is a serious health hazard and can be fatal. (Even that "nice woodsy" smell associated with wood fires, caused by mild smoke spillage is unhealthy and should be avoided.)

Temp-Cast fireplaces have been tested in the most air-tight homes in North America - the Canadian R2000 standard, which allows for only 1/4 air change per hour. Even in this extremely tight house construction, ***the Temp-Cast did not de-pressurize the home.***

In field tests of Canadian homes, varying degrees of combustion spillage in assorted furnaces, fireplaces and wood stoves were detected in an alarming percentage of the homes tested. In addition, smoke spillage was observed at the exterior fresh air intake of a factory-built fireplace. Just because we call it an intake doesn't mean that air will flow in - it will flow in the direction dictated by the pressure of the house.

The Stack Effect

In many 2 or 3 story homes, another phenomenon which effects draft sometimes occurs, called the **stack effect**.

A good chimney system, as we have seen, will be a tall column or stack, insulated from the cold outside air, with an opening at the top.

If the warm air in the home has an easy access out of the house in the upper floors, such as through leaky windows, then the whole house may become a chimney stack - a tall column of warm air with an opening at the top.

With the *stack effect*, cool air is drawn into the home in the basement, through leaky walls, and doors (i.e. a "drafty" basement) or ***down the furnace or fireplace chimney***. The warming air flows up through the middle of the house and exits near the roof. The stack effect can be mild, causing occasional spillage or it can be strong enough to create a flow reversal in basement chimneys. Locating the chimney completely inside the warm envelope of the home, the preferred location for a Temp-Cast heater, helps to prevent this problem.

Replacement Air

When planning your home and your Temp-Cast installation, ensure that the total air requirements of the house, its occupants, exhaust devices and all combustion appliances are considered.

Make-up or replacement air may be required in some installations - be sure to consult your builder or architect.

Footings, Foundations & Floor Pads

The footing dimensions are 4" (100mm) larger than the foundation dimensions in all directions. Ideally, footings should be at least 8" (200mm) thick and reinforced with 1/2" (12.5mm) steel rod, laid in a grid pattern, 6" (150mm) on centre, starting at least 3" (75mm) in from the outside edges. The footing must be built on compacted undisturbed soil or another stable material.

A concrete floor pad is poured on top of the foundation, over a temporary support, which must be completely removed after the concrete has set. The concrete floor pad for a single heater must be at least 6" (150mm) thick and ideally have 1/2" (12.5mm) reinforcing bar laid in a grid 6" (150mm) on centers, starting at least 3" (75mm) in from the sides.

Provision must be made in the concrete floor pad for an air intake slot and an ash drop. (See Section 5.)

The floor pad also serves as the hearth in front of the fireplace, required 16" (400mm) in front and at least 8" (200mm) either side of the loading doors, as detailed in the plans included in Section 5.

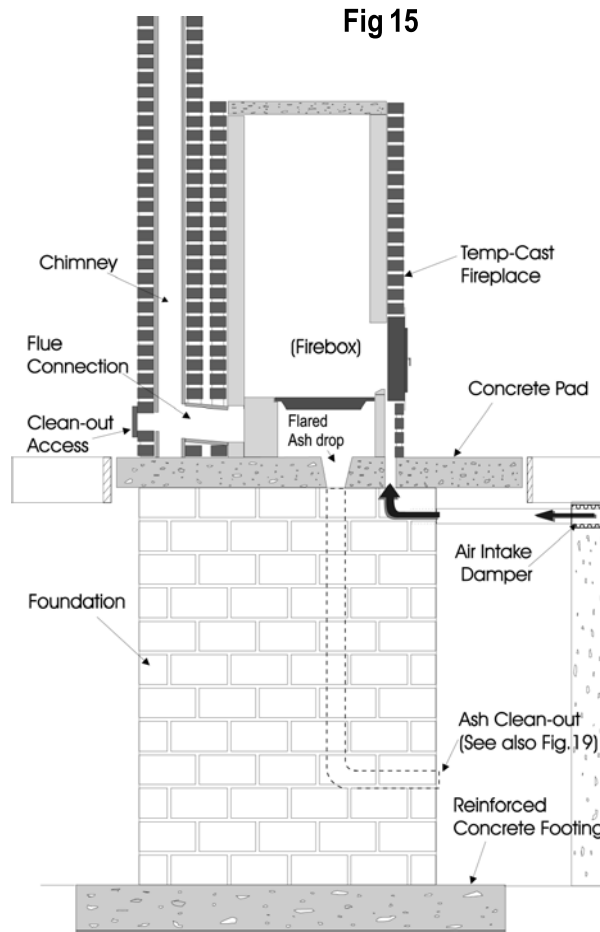

Leaving one side of the foundation open will allow the hollow core to be used for storage and permit access to the fireplace air intake and ash dump. (See Fig. 16) In this case, a site-fabricated metal boot should be used to connect the air intake to

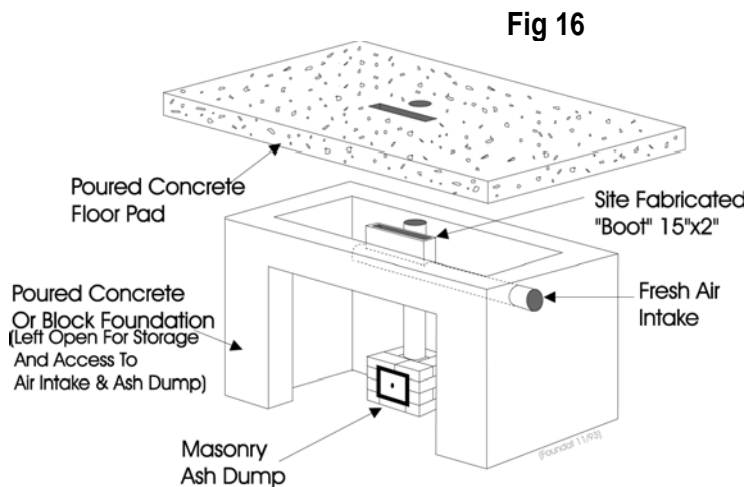

the 6" (150mm) exterior fresh air supply and a metal pipe or masonry chase used for the ash dump.

Combustion Air Supply

Independent testing has shown that Temp-Cast heaters do not require an outside air supply, since they will not depressurize even extremely tight homes. We recommend using inside combustion air wherever possible. (An optional air-intake door is available for this purpose.)

If required by local building regulations, outside air can be provided with an optional air intake damper and locally obtained pipe. A 6" (150mm) round smooth duct is built into the top course of foundation blocks, which will feed necessary air into a 15" x 2" (380mm x 50mm) hole located in the floor pad, directly in front of the unfinished core. The duct is vented to the outside wall under the floor joists and can be equipped with an optional electrically operated damper.

Activating the switch opens the damper to provide outside air for the duration of the burn and is closed when burning is complete. **The intake should be installed on the windward side of the house, at the lowest point available.**

Double-Stacked Fireplaces

When additional heat beyond the capacity of one fireplace is needed, two fireplaces can be built, one on top of the other, on two different floors of the home.

Double stacking fireplaces in this way saves the expense of separate footings and foundations, since they share one footing and the lower fireplace masonry work acts as the foundation for the upper fireplace.

In addition, two flues can be contained in the same chimney, for additional labor and material savings. The fireplaces then work independently of one another and may be fired alternately or together (draft permitting.)

Footings in this case should be 12" (300mm) thick, with 2 grids of 1/2" (12.5mm) reinforcing bar 6" (150mm) on centers. One grid is placed in the bottom third of the footing, and the second is placed in the top third. The lower fireplace facade is carried to the ceiling level, a non-combustible support such as metal roofing is placed on top, and the floor pad for the upper fireplace is poured over it.

Chimneys for Double-Stacked Fireplaces

When double-stacked units are being considered, **each unit must have its own flue.** Chimneys for double-stacked units can be placed on left and right sides of the two heaters, or located at the rear of the heater, or on the same side of the heater, which is the least expensive option. (See Fig. 17 for this option. Other PlanViews can be found in Section 5.) In each case, the chimneys are supported on the lowest level. The flues continue through the concrete floor pad of the upper fireplace but the

brickwork of the lower chimneys stops just above ceiling level and the upper floor pad is poured on top of these bricks, around the flue tiles. This allows the lower chimney brickwork to act as the support for part of the upper floor pad and chimneys.

NOTE: each chimney flue may only service one fireplace and may not be connected to any other appliance.

function and ash cleanout are physically separated, to prevent excess air entering the firebox via the ash drop hole under the firegrate. Excess air into the fire from below may increase particulate emissions, and defeat the door air-wash system.

Fig 17

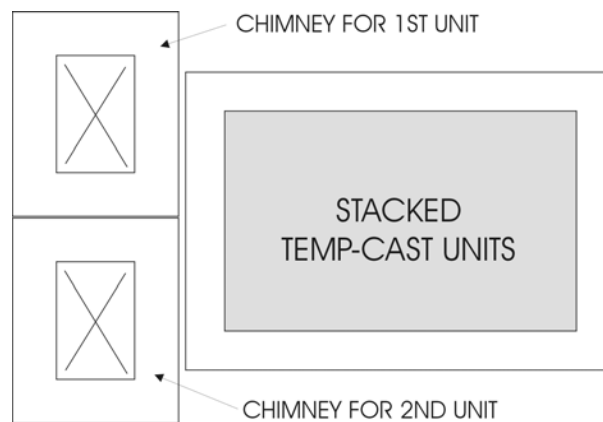

Ash Removal

An ash drop can be easily incorporated in the floor pad. A 6" (150mm) diameter hole is formed in the pad so that ashes drop into a 6" (150mm) suitable metal pipe to the bottom of the block foundation. A masonry ash dump with a chimney clean-out door can be constructed (*as in Fig.16*) or the ash pipe can simply be fitted with a tight end-cap. (*If the foundation is not left open, this pipe is continued to the outside of the foundation and capped or terminated at a soot door, as in Fig.15*)

Ashes for the upper unit in a double-stacked installation can be removed by lifting out the firegrate in the firebox.

Whatever method is chosen for handling ashes, care must be taken to ensure that the air intake

Clearances & Building Codes

Although Temp-Cast fireplaces are efficient heaters, they are also site-built masonry fireplaces constructed of refractory components and as such conform to national building codes in Canada and the United States.

We don't recommend that you enclose your Temp-Cast fireplace in any type of wall, since you will be hindering some of its radiant ability. However, if a wall enclosure is unavoidable, clearances of 4" (100mm) to combustible construction on the sides and back of the fireplace and 10" (250mm) clearance overhead are required. In addition, a hearth extension of 16" is required in front of the fireplace doors. (Refer to fig. 18 & 19).

Combustible materials should not be placed within 48" (1200mm) in front of the fire doors. In most jurisdictions, masonry chimneys and most factory-built chimney systems also require a clearance to combustibles of 2" (50mm) from top to bottom.

NOTE: a combustible wall with non-combustible material applied directly to it without an intervening air space *IS STILL A COMBUSTIBLE WALL FOR PURPOSES OF CLEARANCES*. If clearances must be reduced, a simple method is to build a wall behind the fireplace, in the area of concern, constructed of "cement board" (a 1/2" [12.5mm] cement sheet) installed on metal studs. This wall section must extend 8" (200mm) beyond the sides of the fireplace.

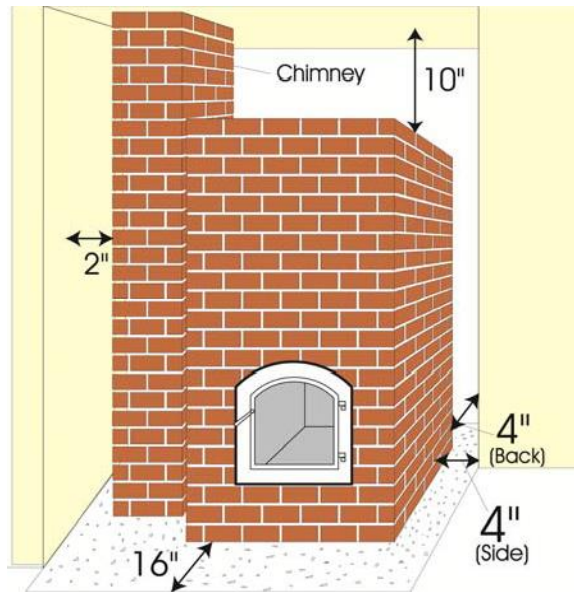
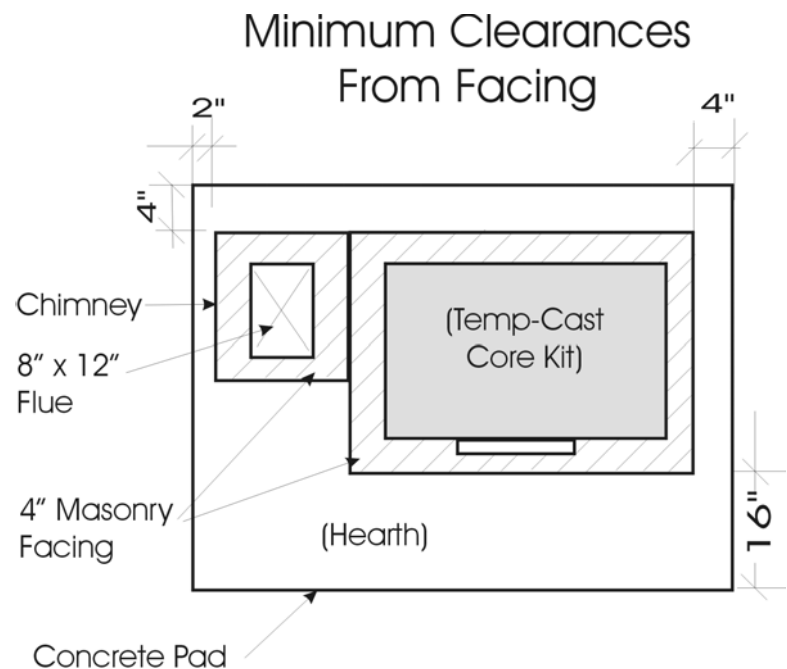

Fig 18

NOTE: Where the precise overall dimensions of the Temp-Cast and its facade are critical, for clearances, support or other reason, the masonry facade material must be chosen before final dimensions can be determined. Your mason must be consulted, to determine the final lay-out of the facade, which in many cases results in greater overall dimensions than indicated on the plan drawings in Section 5. If in doubt that there will be at least 4" clearance all around, allow an extra few inches to be certain.

Fig 19



Wood Storage

Temp-Cast fireplaces perform equally well with softwood or hardwood up to 3" diameter, lumber scraps, branches, or bundles of twigs, up to 50 lbs (22kg) per firing. ***The only requirements are that the wood be dry (20% moisture or less) and suitably sized.*** Ideally, the pieces should be approximately of the same diameter, so that they burn at about the same rate, for maximum efficiency. Reserve larger pieces (up to 4" [100mm] diameter) for adding when the firebox is fully heated.

Outdoor wood storage must ensure that the supply is loosely stacked (criss-cross or "log-cabin" style is best) so that air can circulate around all pieces. The wood supply should have a roof to keep off rain and snow and should also be open enough on all 4 sides to allow good ventilation.

Improper storage may prevent the wood from drying to the proper moisture content of 20%. Wood that is not dried to this level of moisture may create excess air pollution and impair the heating ability of the fireplace.

Planning Summary

By taking into consideration the facing thickness, clearance to combustibles, chimney location & type, hearth size, etc, you can now do preliminary sketches showing the fireplace, chimney, supporting floor pad, foundation and footing. (Keep in mind it is generally easier to build a rectangular pad than one that tries to follow the shape of the heater-chimney-hearth footprint.) For your convenience, we have included several of the most common plan designs and details at the end of this guide.

Additional Sources of Information

Considered by many to be the most comprehensive book written on masonry heaters, "***The Book of Masonry Stoves***", by David Lyle, can be obtained by writing to Heating Resource Company, Box 300, Acworth NH 03601.

The Canadian Government also has an excellent new publication, "***A Guide to Residential Wood Heating***", from Energy Publications, Canada Communications Group, Ottawa, Ontario K1A 0S9. (Fax# 819-994-1498)

Involving Professionals

Many homeowners are able to successfully plan their own fireplace installations with this booklet and the included plans.

However, for special requirements, you may also want to consider the services of a professional. Your architect and contractor are experts in their various fields who can provide essential services.

Please contact us directly if clarification of any point is needed or if you would like to receive our installation and promotional video.

Tel# (651) 303-9841

staywarm@tempcast.com
www.tempcast.com

DUE TO VARIANCE IN SOIL, SEISMIC, AND OTHER LOCAL CONDITIONS, WE RECOMMEND THAT YOU CONFIRM ALL DIMENSIONS FOR FOOTINGS, FOUNDATIONS, FLOOR PADS AND CLEARANCES WITH YOUR LOCAL BUILDING AUTHORITY.

Section Summary

- ***Masonry heaters are heavy & require adequate footings and foundations.***
- ***Chimneys start at floor level & can be masonry or prefabricated stainless steel.***
- ***All chimneys must be inside the warm envelope of the home and be fitted with a damper.***
- ***Temp-Cast heaters will not de-pressurize even extremely air-tight house designs.***
- ***Dry wood (of any untreated kind) is essential for optimum performance.***
- ***Basements are poor locations for any solid-fuel appliance, especially with an exterior chimney.***
- ***Temp-Cast heaters can be stacked.***
- ***Ashes can be planned to drop into the basement for ease of cleaning.***
- ***Temp-Cast heaters conform to national building codes in Canada & the United States.***
- ***Building officials must be consulted to verify special local requirements.***

Section 5 - Installation Notes & Plan Drawings

This section provides construction notes & dimensions for the most common heater & chimney layouts for the Temp-Cast wood-fired heater. (See Metric equivalents at the end of this section.)

Notes to Plan Drawings:

- Temp-Cast fireplaces are "site-built" masonry fireplaces, constructed of refractory parts installed with refractory mortar. When faced with the required 4" (100 mm) of **solid** masonry and connected to an approved chimney system, they conform to building codes across North America.
- Combustion air is fed into the fire from an air slot in the bottom of the door frame. The mason must create this air slot, by slicing the masonry or stepping it out from the core. Combustion air, from the basement or from outside, is supplied via a 15" x 2" (380 mm x 50 mm) air slot in the concrete floor pad. (Care must be taken to ensure that the air slot in the concrete floor pad is not obstructed by the foundation below.)
- If outside combustion air is required, a 6" (150 mm) outside air supply can be connected to a fresh air intake and controlled with an optional electrically operated damper. **Note:** in the case of See-Through units, an 8" (200mm) air supply is required, and half of the available air must be directed to the air intake slot of each door frame.
- In a basement installation, where outside air is not required, an optional air supply door will be needed, to feed air in behind the masonry facade and into the air slot in the bottom of the door frame.
- If an open foundation plan and outside air supply is used, as shown in drawings, then a metal "boot" must be custom fabricated on-site to connect the air supply to the air slot formed in the concrete floor pad.
- Minimum clearances from masonry facing (eg. brick or stone façade) to combustible materials are 4" (100 mm) on the sides, 4" (100 mm) at the back, 2" (50 mm) from the chimney and 10" (250 mm) above the top of the heater. Regardless of the facing chosen, or whether it will be visible or not (eg. on the back or sides), the 4" minimum masonry facing must be continuous on all sides and the top of the heater. ****Failure to follow these requirements will create a fire hazard.****
- Chimneys are connected at the base of the fireplace (in the first course) and are supported on the concrete floor pad, or on the footing.
- A minimum thermal break of approximately 1/4" to 1/2" (6 mm to 12 mm) should be maintained between chimney facing and fireplace facing. (This space can be hidden with a facade that encloses both chimney and fireplace.)
- Chimney connections can be made at either side or rear of a Standard fireplace, or at the rear or on any of the 4 angled facets of a Corner fireplace.
- Plan drawings are **not to scale.** Dimensions are based on a **4" (100 mm) clay brick or stone** façade, which is the recommended façade thickness. Facings of up to 5" [127 mm] overall thickness of solid masonry can be used, but all plan dimensions will require adjustment. *(Note: it is recommended that the facing material be chosen first, before determining the positioning of the Temp-Cast heater, concrete slab, foundation and footings. This is especially important where space is limited or where clearances to combustibles will be an issue. We recommend that you involve your mason in the planning process as early as possible to ensure a smooth installation.)*

- When stone or rock is chosen as the facing material, additional back-up blocks are usually required around the chimney - this additional material will require appropriate alterations to the given plan dimensions. (Concrete block facings are not recommended.)

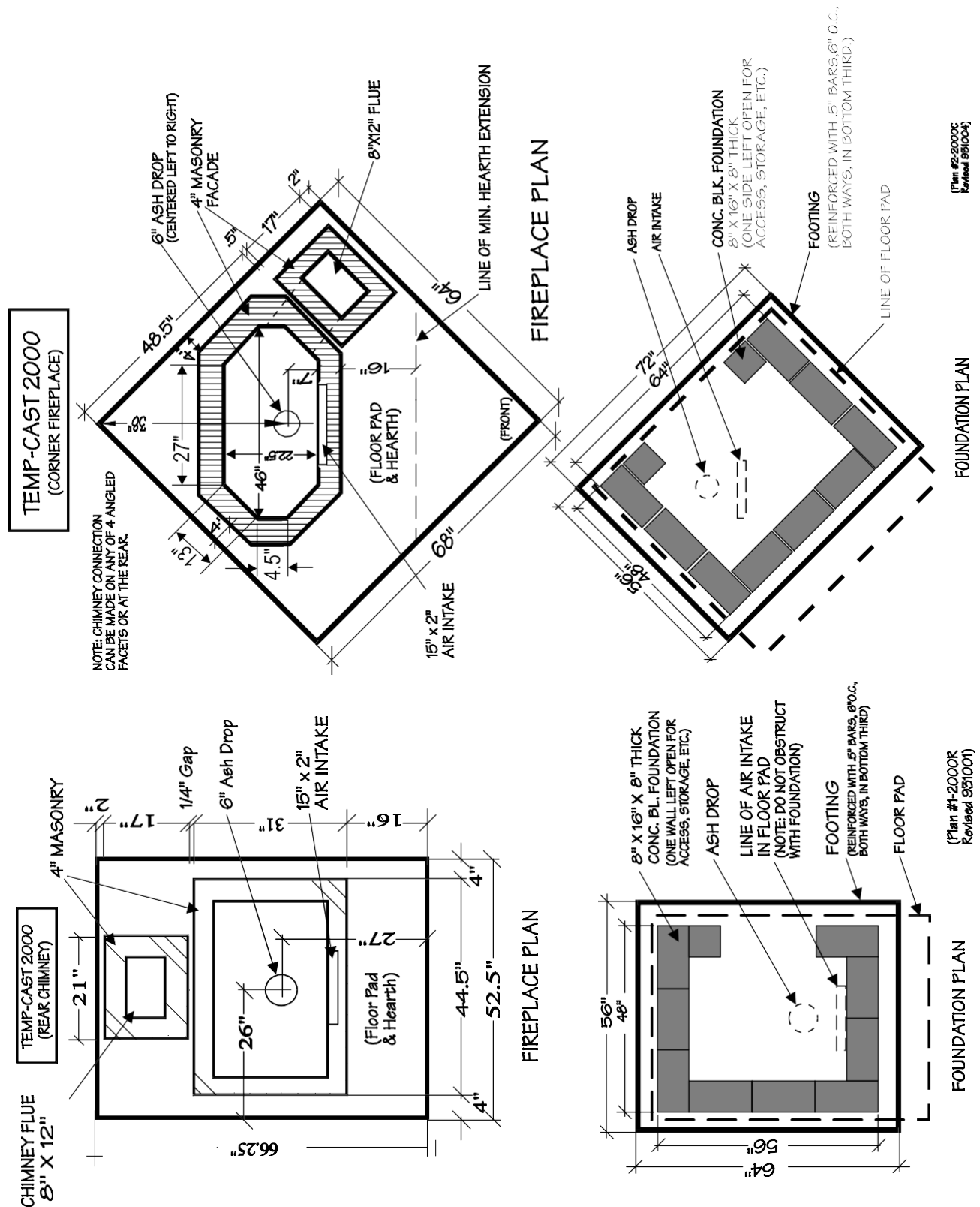

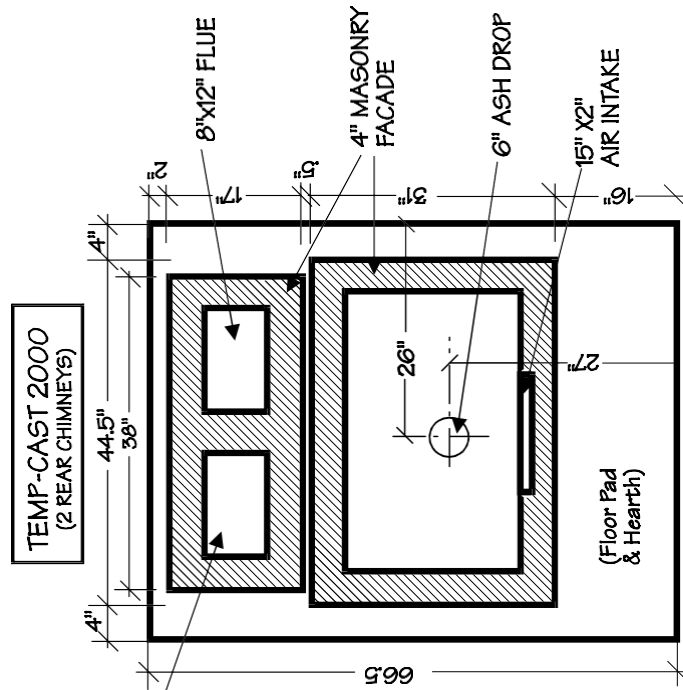

FIREPLACE PLAN

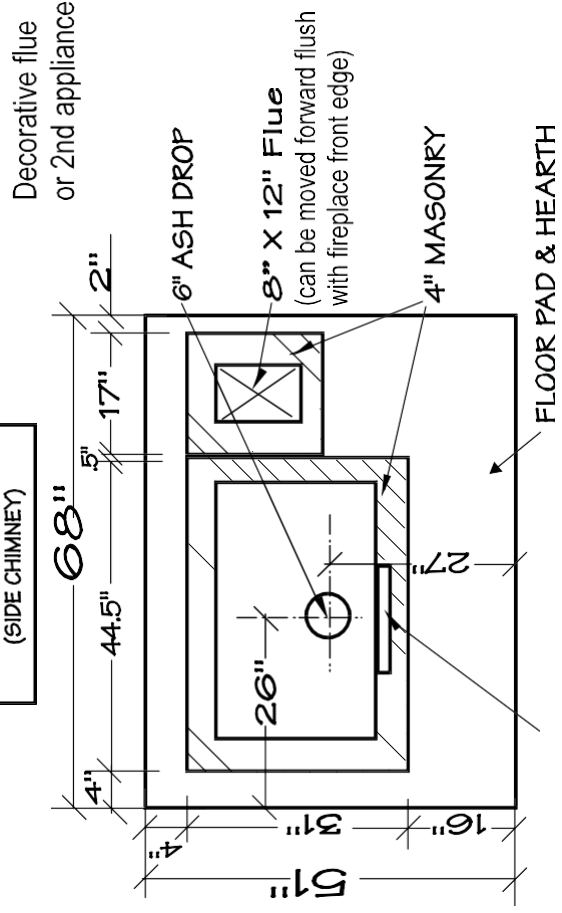
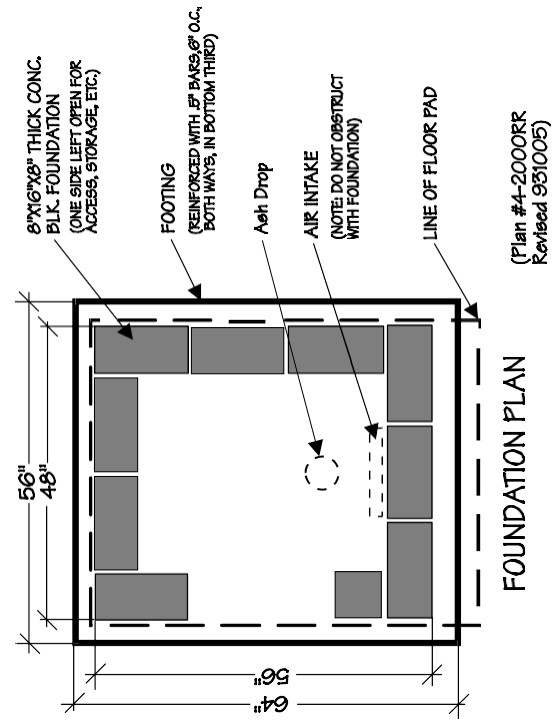

FIREPLACE PLAN

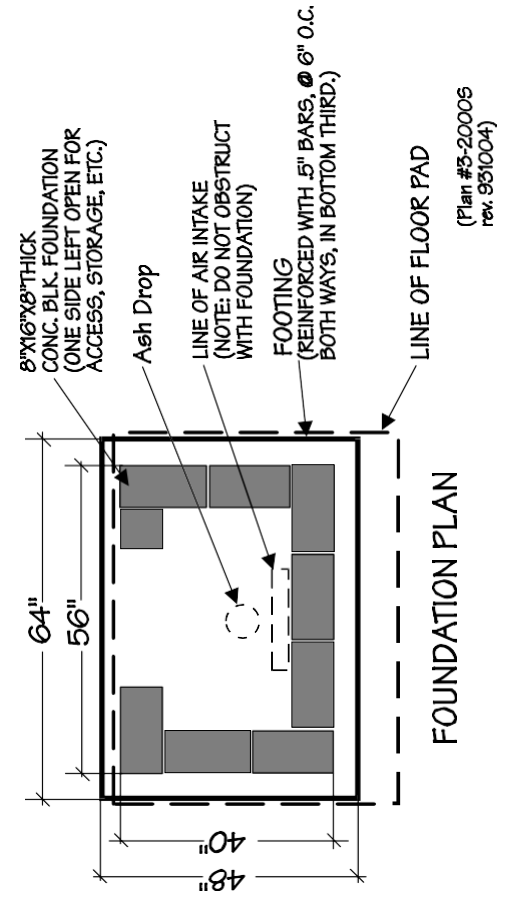

NOTE: If back-up block is required around the chimney, (eg. for stone facings), footing, foundation and pad dimensions will require suitable adjustment.

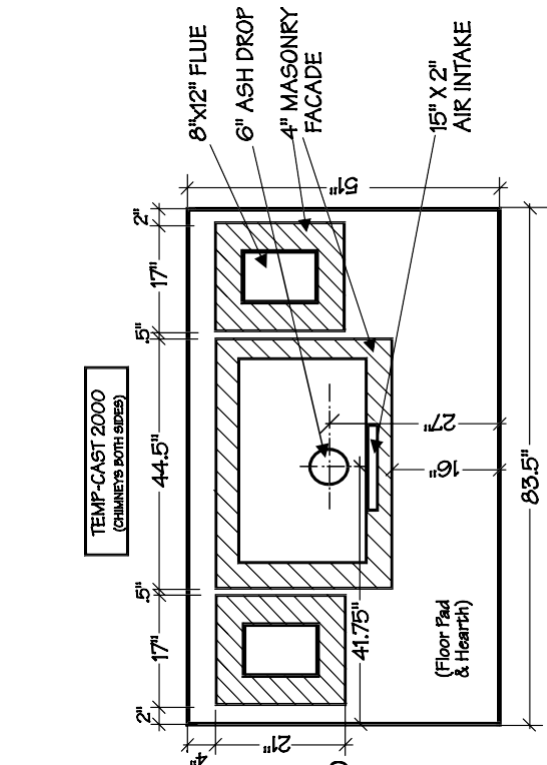

FIREPLACE PLAN

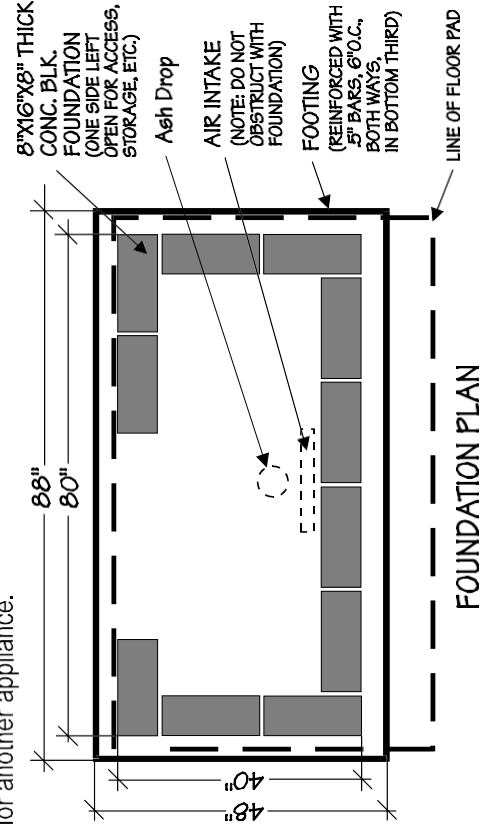

FOUNDATION PLAN

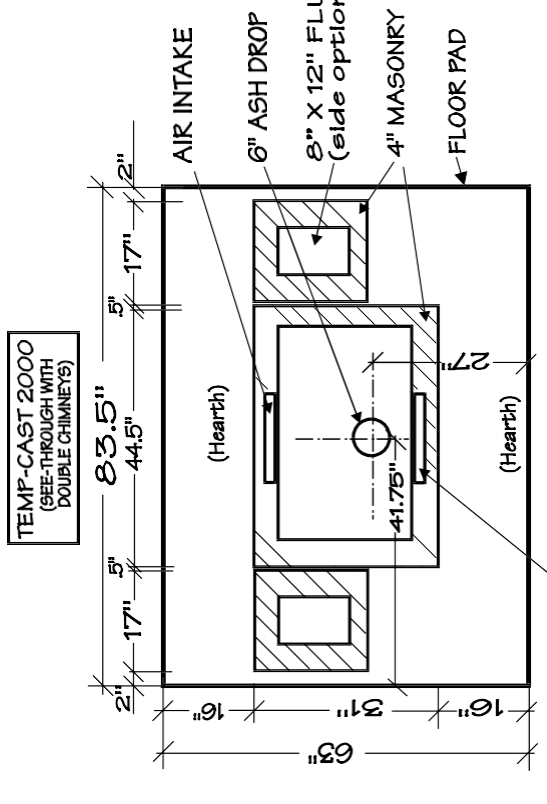

15" X 2" AIR INTAKE FIREPLACE PLAN

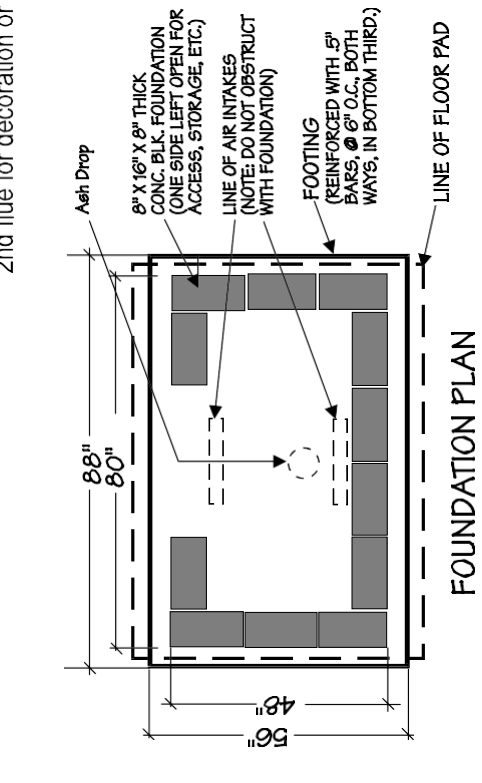

FOUNDATION PLAN

Note: heater requires only 1 chimney flue - 2nd flue for decoration or for another appliance.

NOTE: If back-up block is required around the chimney, (eg. for stone facings), footing, foundation and pad dimensions will require suitable adjustment.

IMPERIAL TO METRIC TABLE (Converted values may be rounded up or down for simplicity)

<u>inches</u>	<u>mm</u>
0.25	6.35
0.5	12.7
2	50.8
4	101.6
4.5	114.3
6	152.4
7	177.8
8	203
10	254
12	304.8
12.25	311.15
13	330.2
14	355.6
15	381
15.5	393.7
16	406.4
17	431.8
17.75	450.8
18.5	469.9
20.5	520.7
21	533.4
21.75	552.4
22.5	571.5
23.5	596.9
25.5	647.7
26	660.4
27	686.8
31	787.4
36	914.4
38	965.2
40	1016
41.75	1060.4
44.5	1130.3
46	1168.4
48	1219.2
48.5	1231.9
51	1295.4
52.5	1333.5
56	1422.4
64	1625.6
66.25	1682.7
66.5	1689.1
68	1727.2
72	1828.8
77	1955.8
80	2032
83.5	2120.9
88	2235.2