

TABLE 100

MULTI-FUNCTIONAL BASE



SCHEDA TECNICA - TECHNICAL SPECIFICATION

BLACK
ACTAVO-100-NER

A	117.5 cm 46.2 in	C	80 cm 31.5 in
B	100 cm 39.4 in	D	89.5 cm 35.2 in

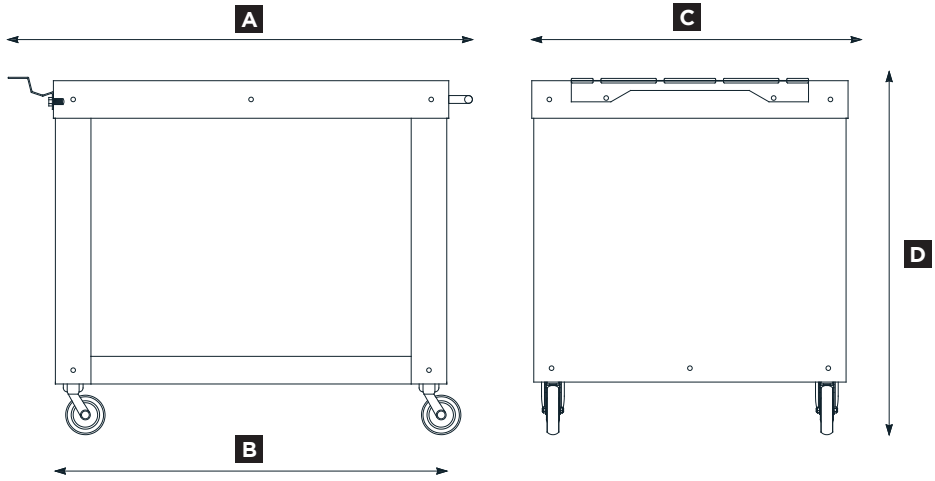

CARATTERISTICHE TECNICHE - TECHNICAL DETAILS

Peso <i>Weight</i>	50 kg 110 lbs	Materiali utilizzati <i>Used material</i>	lamiera ferro, acciaio inox <i>iron sheet, stainless steel</i>
Area piano di Lavoro <i>Working floor area</i>	0.8 m ² 1240 inc ²	Dimensione piano di lavoro <i>Working floor dim.</i>	100x80cm 39.4x31.5 in

PARTI DI RICAMBIO - SPARE PARTS

Descrizione <i>Description</i>		Codice <i>Code</i>
Portapale tavolo <i>Rack tavolo</i>	A	BAS-03-0055
Piano di lavoro <i>Working floor</i>	B	SBAS-01-018
Pannello Laterale <i>Side panel</i>	C	SBAS-03-0101-NE
Ripiano inferiore <i>Lower Shelf</i>	E	SBAS-02-009-NE
Maniglione <i>Handle</i>	F	D14MAN-37821
Ruote girevoli con Freno <i>Wheels with brakes</i>	G	D14RU-125FRGN

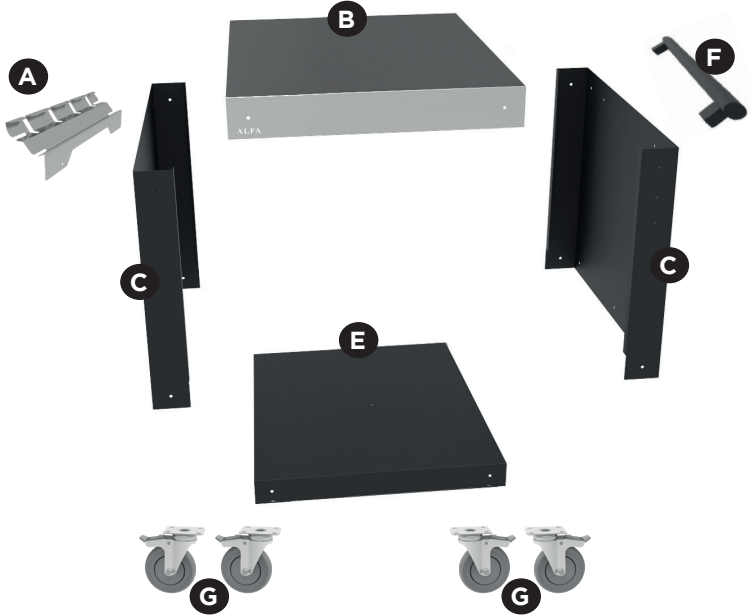

DIMENSIONE IMBALLO PACKAGING			
Larghezza <i>Width</i>	Profondità <i>Depth</i>	Altezza <i>Height</i>	Peso <i>Weight</i>
105 cm 41.3 in	85 cm 33.5 in	28.5 cm 11.2 in	70 Kg 154 lbs



WATCH THE VIDEO, SCAN THE QR CODE

VIMEO.COM/295796645

