

MASATA

Installation Guide

MST7000

BMW G80 G82 S58 | M3, M3 Competition, M4 & M4 Competition

This product has been designed and manufactured to work correctly with installation as described in these instructions.

Failure to follow these instructions could result in damage to property, damage to the product and or potential injury.

It is very important that you read and understand these instructions thoroughly before installing this product.



masata.co.uk



info@masata.co.uk

BMW S58 3 channel tuning module

Included Contents

- Tuning Module
- Wiring Loom
- Fastening Ties
- Installation and User instructions
- Protective Bag For Module - (prevents damage to unit casing)

Before Installation

1. Open the vehicle's bonnet
2. Remove the ignition key
3. Close and lock the doors
4. Wait 5 minutes before removing any electrical plugs

Installation Location

The module should be installed between the vehicle's Rail and Boost Pressure sensors as shown in the diagram.

Locating the Unit

The unit itself should be mounted away from



Sources of Extreme Heat



Sources of Vibration



Sources of Spray Water



Do not open the vehicle doors or unlock the vehicle while installation is in progress

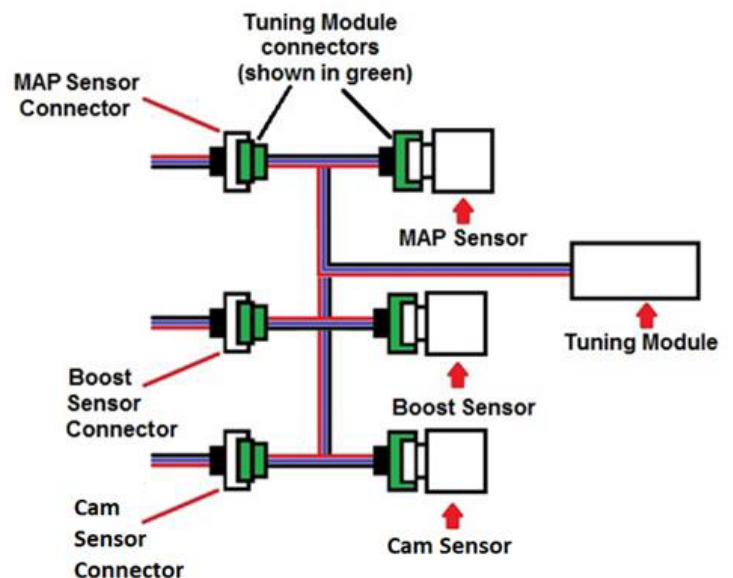

H4m-H3b-H3c-819

MASATA

STEP 1

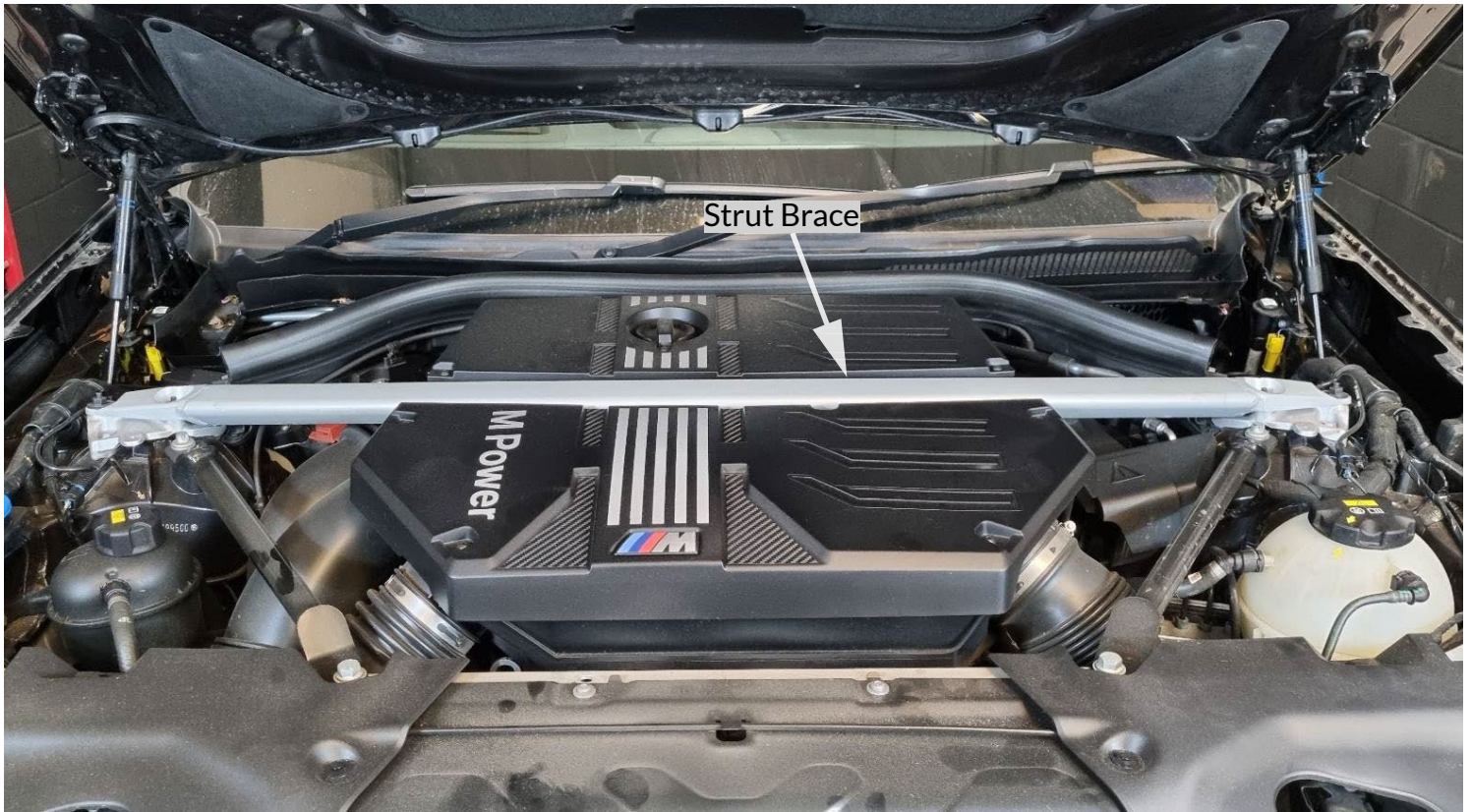

- Ensure that your engine looks similar to the supplied photographs. (minor changes with ancillary components are to be expected, however if the engine looks nothing alike, please contact Support.)
- Make sure that you have a good grasp of the operation of the connector clips and or locking tabs. - If the connectors you are trying to access are in an awkward place, it may be useful to try unplugging (and then re-inserting) a connector on the vehicle which is more easily accessible. Alternatively try plugging together the connectors on the Tuning Module itself.
- Remove the engine strut brace by removing the bolt from both ends.



MASATA

STEP 2

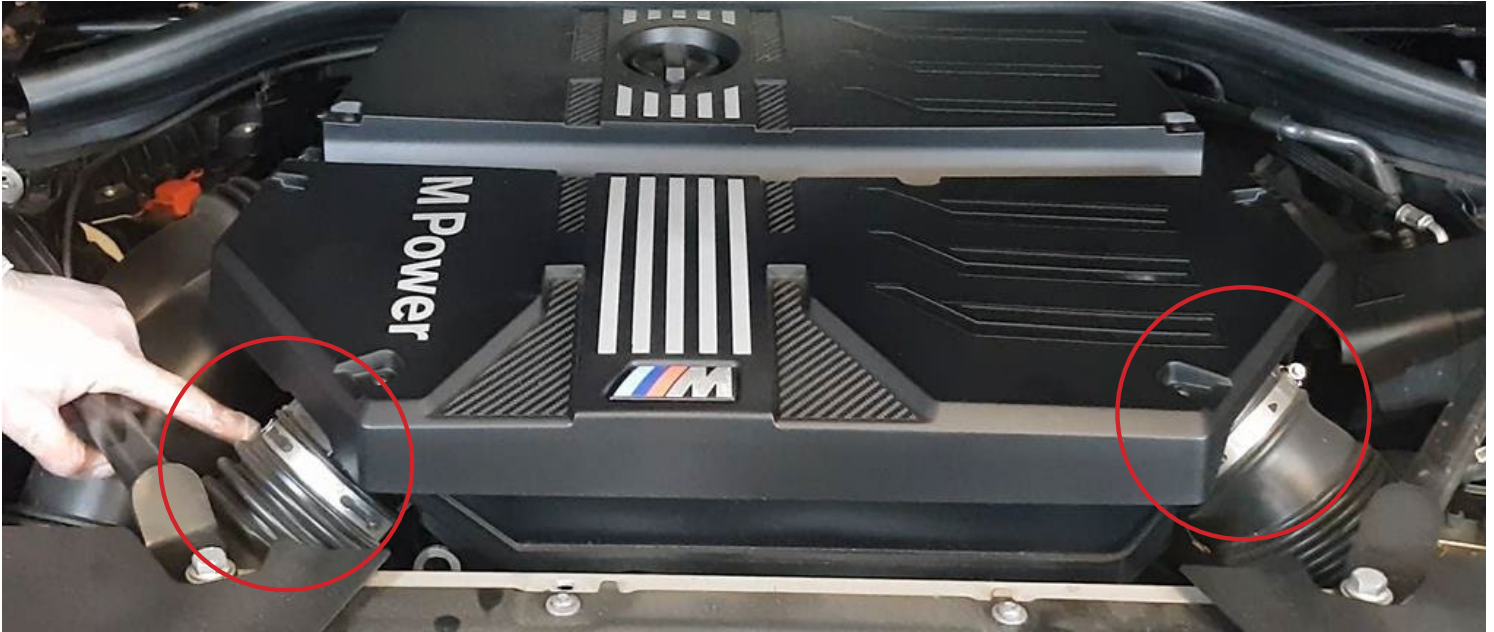

- Remove the airbox by loosening the 4 jubilee clips on the 4 air pipes. You will need a 6mm socket or spanner for this.
- Pull back the pipes from the airbox and give a gentle tug to release the airbox.
- You should be left with an engine that matches the image below.

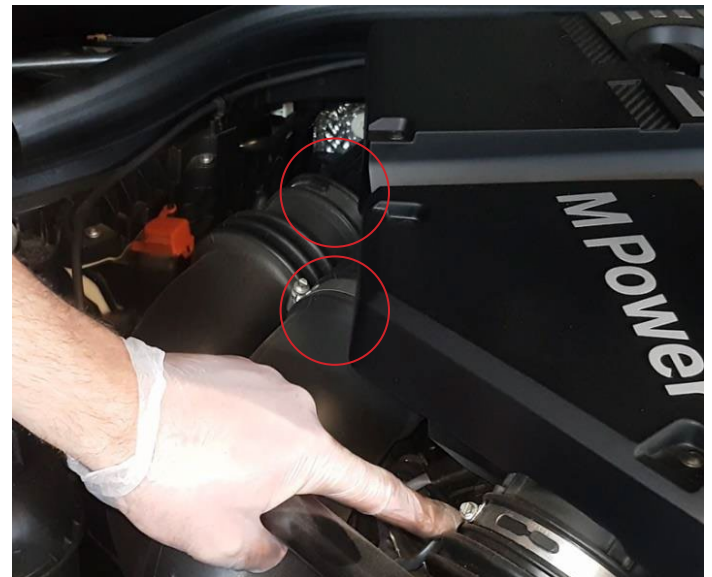

STEP 3a

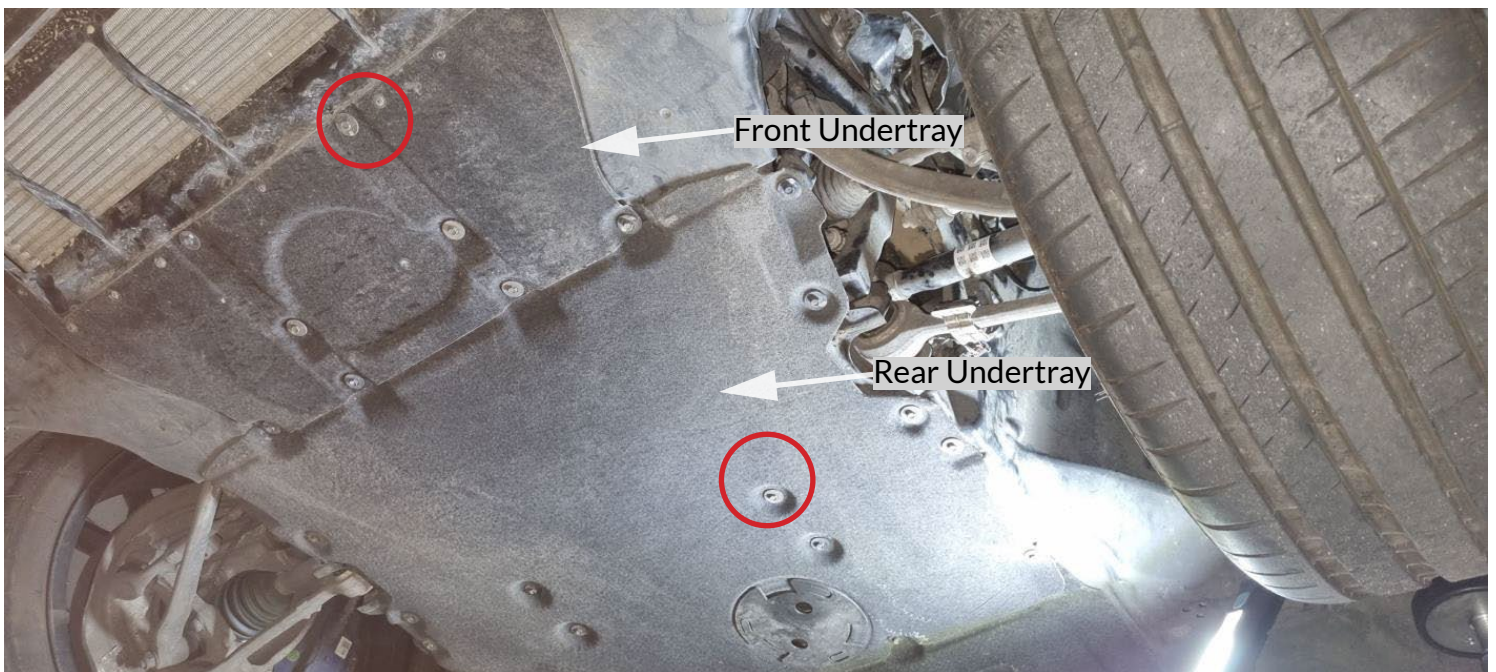

- Lift the vehicle, remove the front undertray by removing the holding bolts using an 8mm socket.
- Remove the front undertray by removing the holding bolts using an 8mm socket.
- With the undertray removed you should be able to see the boost sensor on the boost pipe as pictured.

STEP 3b

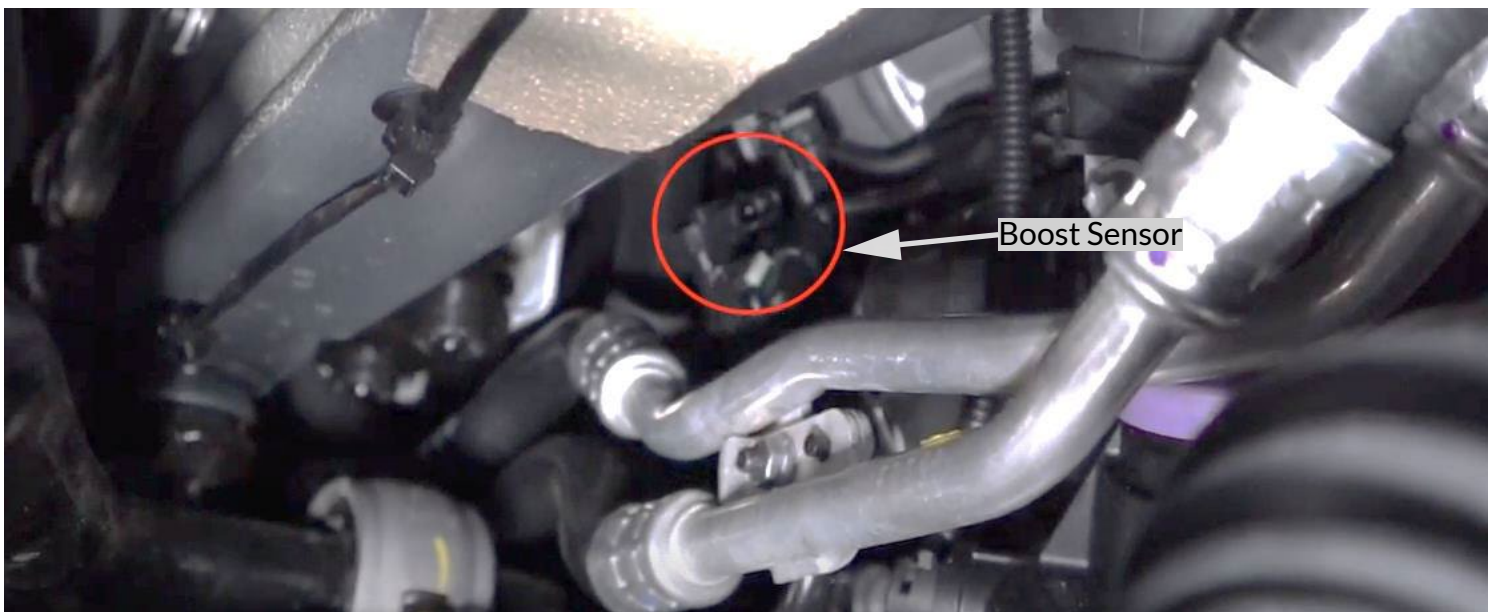

- Unplug the Boost Sensor connector (3 pin) by first pulling back on the locking clip and then pressing down the releasing clip and pulling back on the connector.
- Insert the connector from the Tuning Module's wiring loom into the Boost Sensor.
- Insert the Vehicle's Boost Sensor connector into the corresponding connector on the Tuning Module's wiring loom.

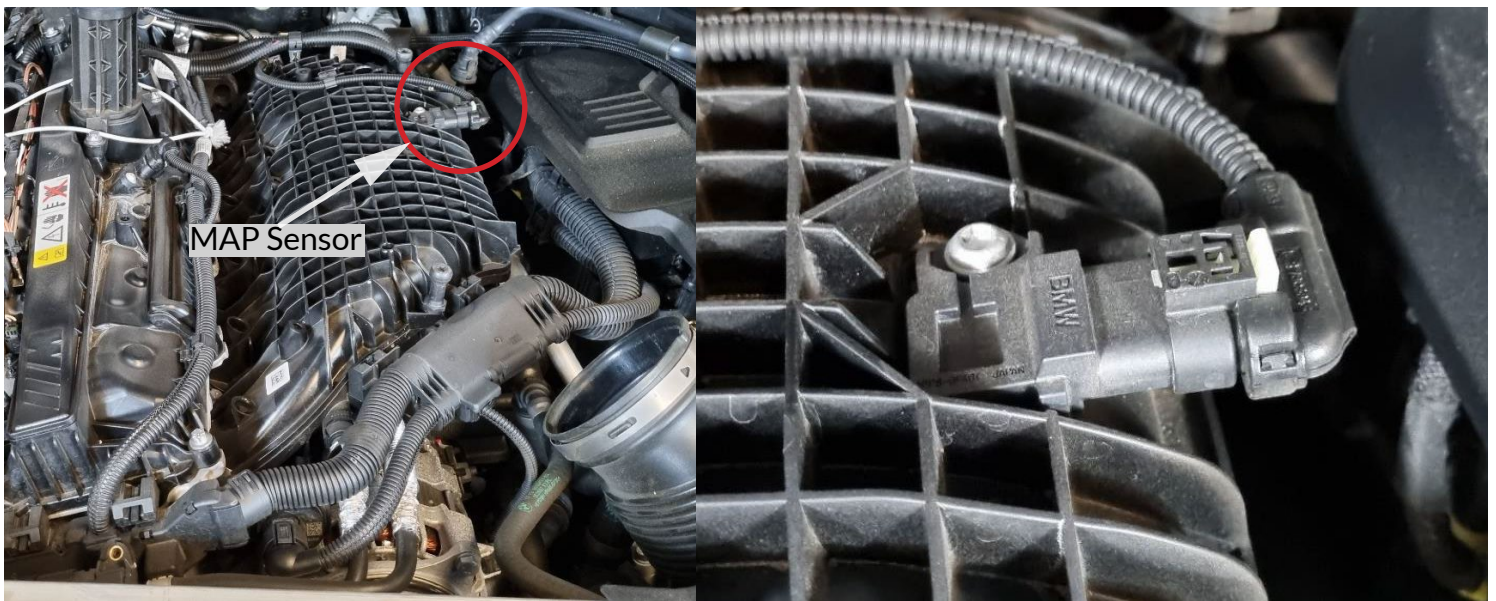

- Unplug the MAP Sensor connector (4 pin) by first pulling back the locking tab and then pressing down the releasing clip and pulling back the connector.
- Insert the connector from the Tuning Module's wiring loom into the MAP Sensor.
- Insert the Vehicle's MAP Sensor connector into the corresponding connector on the Tuning Module's wiring loom.

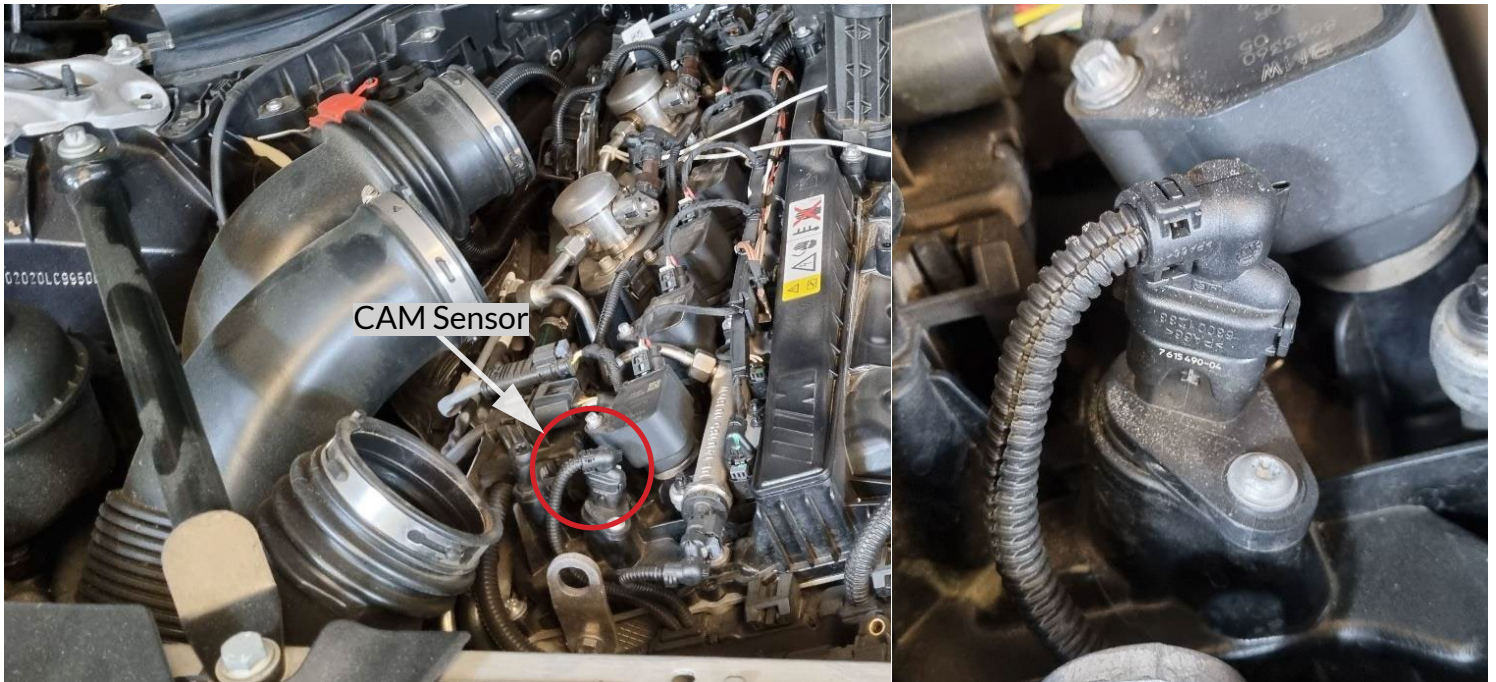

- Unplug the CAM Sensor connector (3 pin) by first pulling back the locking tab and then pressing down the releasing clip and pulling back the connector.
- Insert the connector from the Tuning Module's wiring loom into the CAM Sensor.
- Insert the Vehicle's CAM Sensor connector into the corresponding connector on the Tuning Module's wiring loom.
- Secure the CAM wiring loom using included cable ties.

BMW S58 3 channel tuning module

- With the unit successfully installed please secure the unit and wiring loom within the engine bay, paying attention to the guidelines highlighted on Page 1.



Route the tuning box wiring harness away from sources of heat (exhaust manifolds, EGR pipes, most stainless steel pipes) and also away from any rotating parts such as belts.

- Double check all connections are correct and firmly connected. If this is the case, start the vehicle and ensure there are no engine warning lights or error messages displayed.
- Re-install the undertray and place the engine cover back over the engine making sure it clips in to place.

If everything is as it should be, please feel free to take the vehicle out for a test drive and enjoy the added responsiveness and power added to your vehicle by the Tuning Module.