



Thank you for purchasing our latest compost tumbler. This is a brand-new design and so you are one of the first to try this product. As always but especially with a new item, we would love to hear your feedback about the assembly and the use of this product. Please send your feedback to info@mazeproducts.com.au

The following instructions will detail how to assemble the Maze Compost Tumbler. If you have any problems during the assembly, feel free to contact our office during office hours.













You can visit our website to watch an **instructional video on the assembly** process. Scan QR code or go to: [mazeproducts.com.au/product/180lt-maze-geared-twin-tumbler/](https://www.mazeproducts.com.au/product/180lt-maze-geared-twin-tumbler/) (in the instructions tab)



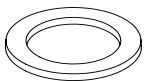

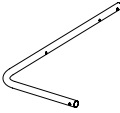
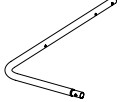
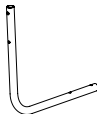
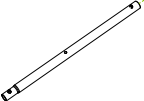

If you encounter **missing or broken parts**, please visit our website and click on the spare parts link (under **Products** heading) to order the parts.

INCLUDED COMPONENTS

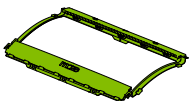
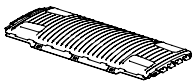
PART	PART NUMBER	QTY	DESCRIPTION
	GAA	4	SNAP FASTENER
	GAB	2	BUTTON HEAD SOCKET SCREW M6x80
	GAC	1	BUTTON HEAD SOCKET SCREW M6x60
	GAF	21 +2	PAN HEAD SCREW M5x16
	GAD	2	WASHER LARGE M6
	GAE	3	NUT NYLOC M6
	GAG	21 +2	NUT FLANGED M5
	GAH	1	BARREL SPACER

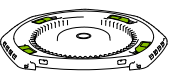
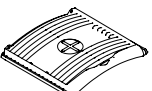
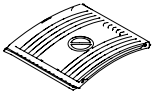
PART	PART NUMBER	QTY	DESCRIPTION
	GG	1	AXLE CHS 25x1.2mm
	GH	1	LEG FEMALE CHS 25x1.2mm
	GI	2	LEG MALE CHS 25x1.2mm
	GJ	1	LEG CORNER CHS 25x1.2mm
	GK	1	LEG SHORT CHS 25x1.2mm
	GL	2	LEG BRACE 5mm ROD
	GM	1	STAND CORNER NO GEAR

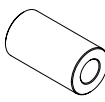
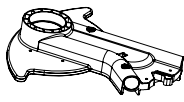
PART	PART NUMBER	QTY	DESCRIPTION
	GA	1	DOOR SURROUND
	GB	6	PANEL
	GC	1	DIVIDER
	GD	2	END CAP 4 VENTS PRE-ASSEMBLED VENT PART GS
	GE	1	DOOR "ADD"
	GF	1	DOOR "DON'T ADD"

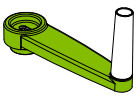
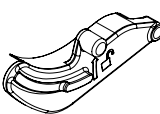
PART	PART NUMBER	QTY	DESCRIPTION
	GN	1	RATCHET BUSH
	GO	1	STAND CORNER GEAR
	GP	1	GEAR
	GQ	1	CRANK ARM HANDLE PRE-ASSEMBLED HANDLE PART GT
	GR	1	RATCHET

TOOLS PROVIDED:

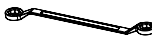
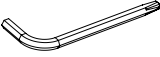
	RING SPANNER 8MM / 10 MM
	4MM ALLEN KEY / PHILIPS SCREWDRIVER

THESE INSTRUCTIONS SUGGEST THE BEST WAY TO POSITION THE PARTS AND BARREL.
PLEASE FOLLOW AS PER THE DIAGRAMS

STEP 1



EACH PANEL HAS A TOOTH EDGE AND A POCKET EDGE

TO CONNECT THE PANELS - OVERLAP THE POCKET
EDGE OF ONE PANEL OVER THE TOOTH EDGE OF THE
OTHER

THEN SLIDE TOOTH EDGE INTO THE POCKET EDGE

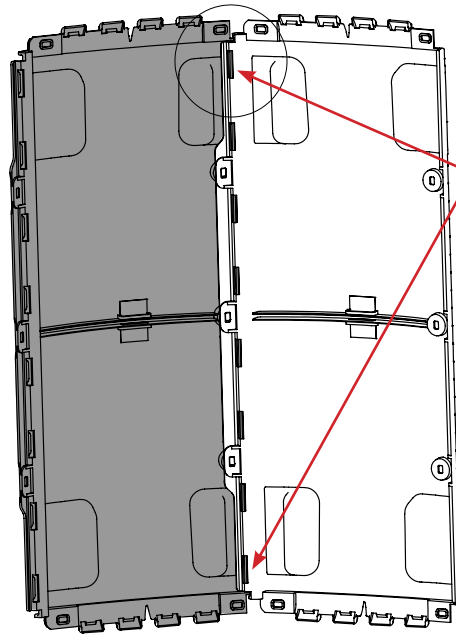
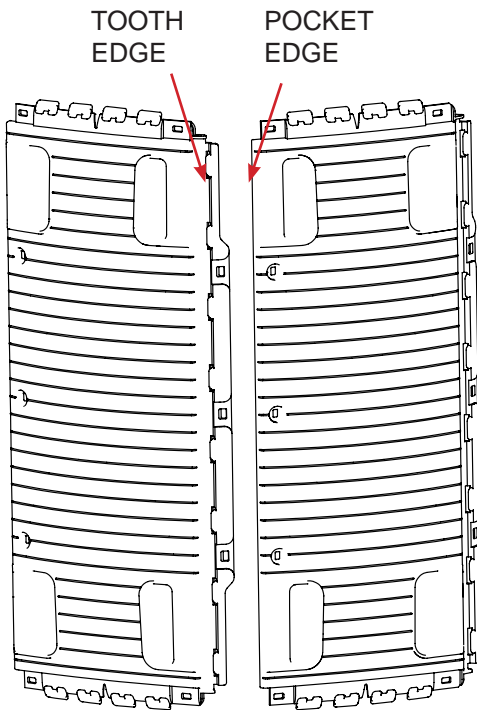
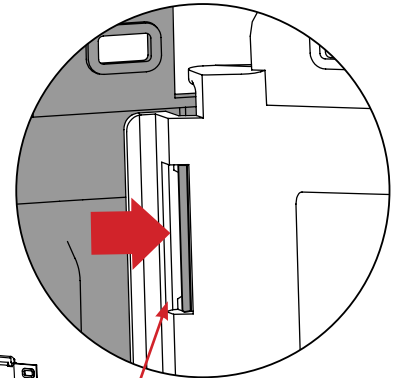

ENSURE EACH TOOTH
ON THE TOOTH EDGE IS
FIT INTO ITS POCKET

YOU SHOULD SEE THIS
IN THE SLOT

STEP 2



PLACE SCREWS THROUGH HOLES
FROM THE OUTSIDE AND TIGHTEN
NUTS ON THE INSIDE.
(USE SCREW DRIVER TOOL AND
SPANNER IF REQUIRED)

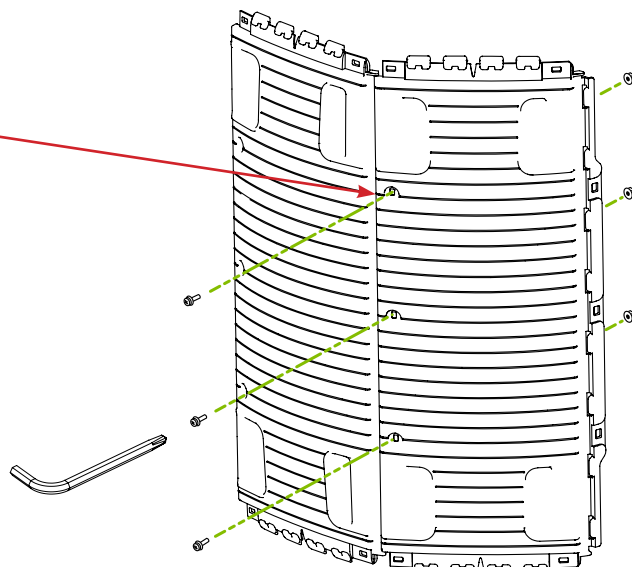
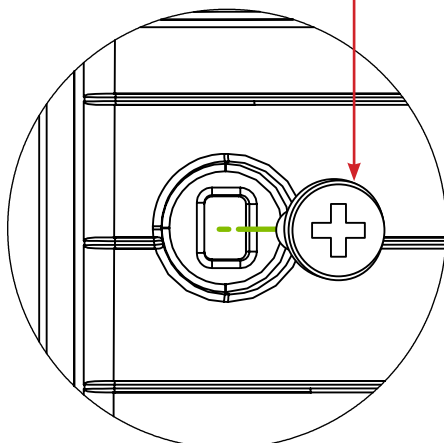

STEP 3

JOIN REMAINING PANELS TOGETHER AS PER STEP 2

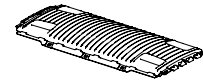

GB x 4

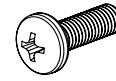

GAF x 12



GAG x 12

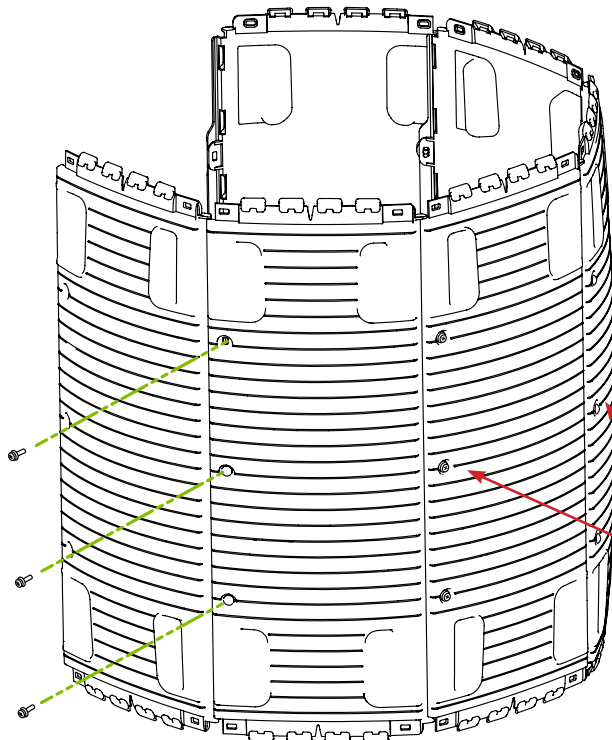

3 x SCREW & NUT PER PANEL JOINT

STEP 4

ATTACH DOOR SURROUND TO ONE SIDE

SECURE WITH 3 X SCREW & NUT

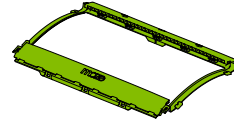

GA x 1

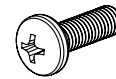

GAF x 3



GAG x 3

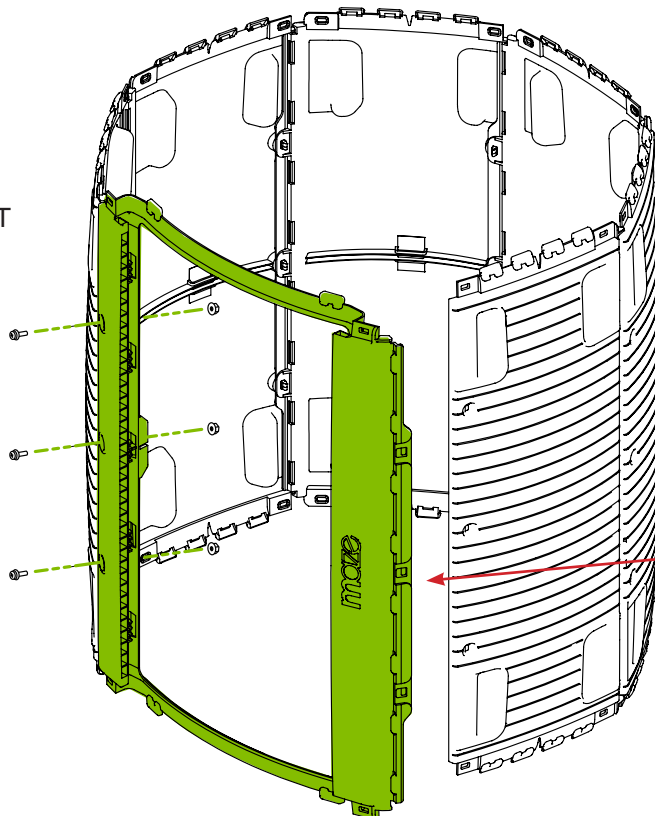

LEAVE A GAP BETWEEN DOOR SURROUND AND LAST PANEL

STEP 5

INSERT DIVIDER INSIDE BARREL



GC x 1

INSERT DIVIDER WITH SMOOTH SIDE FACING DOWN.

THERE IS A CUT SEMI-CIRCLE ON ONE SIDE. THIS SHOULD BE ON THE SIDE YET TO ATTACH.

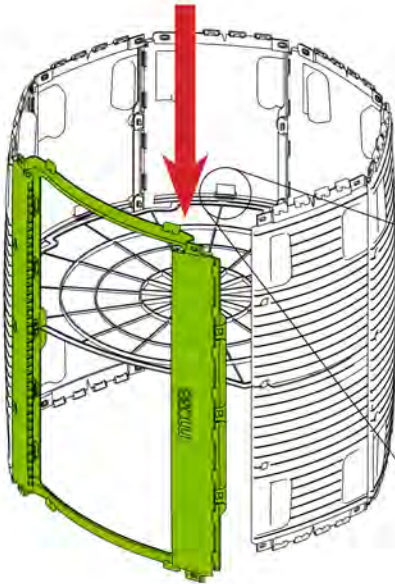

INSERT THE DIVIDER INTO THE GROOVE AT THE CENTER OF EACH PANEL. (x6)



THERE IS A CLIP FEATURE THAT NEEDS TO CLICK INTO THE GAP IN THE PANEL GROOVE (X6 PLACES)

STEP 6

CLIP DOOR SURROUND TO REMAINING PANEL

SECURE WITH 3 X SCREWS & NUTS



GAF x 3



GAG x 3

TIP: FOR MIDDLE SCREW HOLD THE NUT IN THE END OF THE RING SPANNER FOR EASIER ASSEMBLY

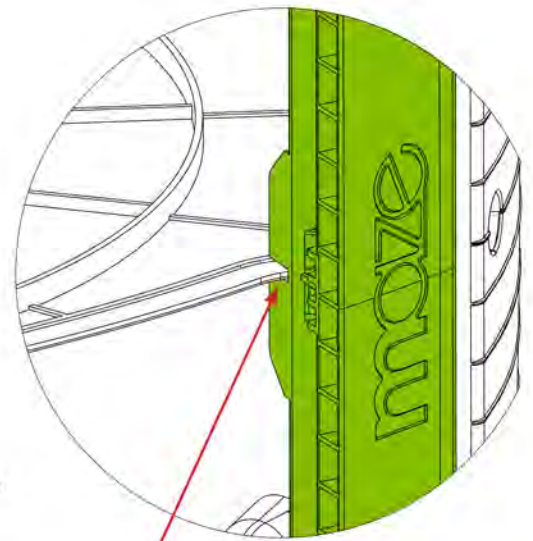
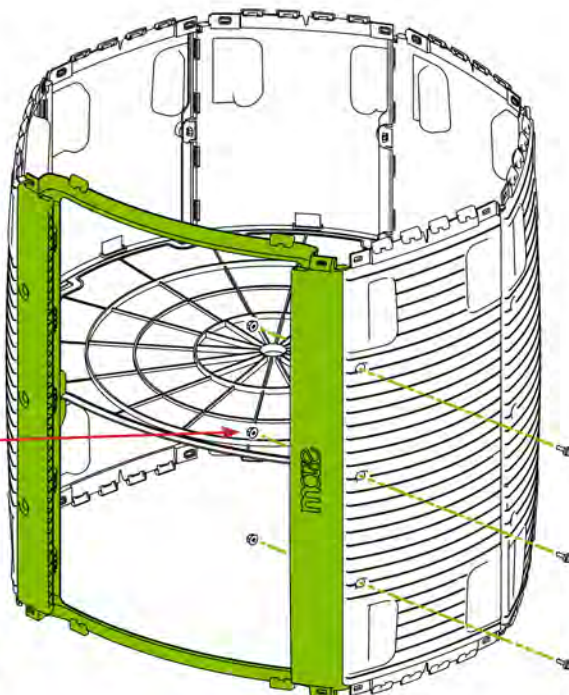

ENSURE DIVIDER IS CLIPPED INTO ALL PANELS INCLUDING BEING BETWEEN THE GUIDES ON THE DOOR SURROUND

STEP 7

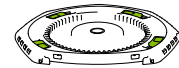

GD x 1

PLACE END CAP ON TOP
AND PUSH DOWN TO CLIP
INTO SIDE PANELS

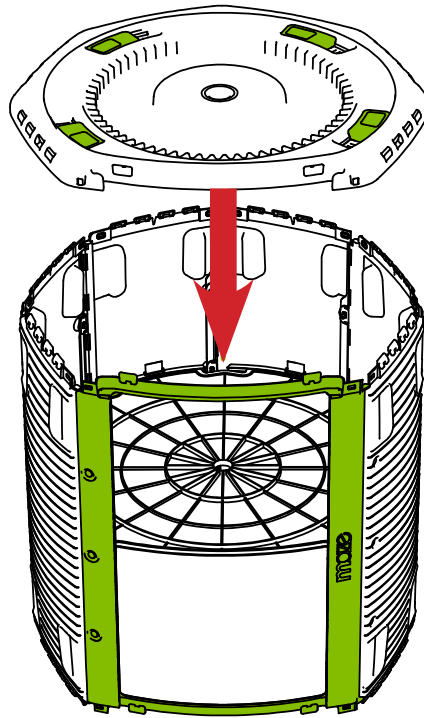

TIP: YOU MAY FIND IT
EASIER IF BARREL IS ON
THE GROUND AND USE
SOME BODY WEIGHT TO
PUSH DOWN

FIRMLY PUSH DOWN ON
EACH EDGE TO ENSURE
PANELS ARE CLIPPED IN

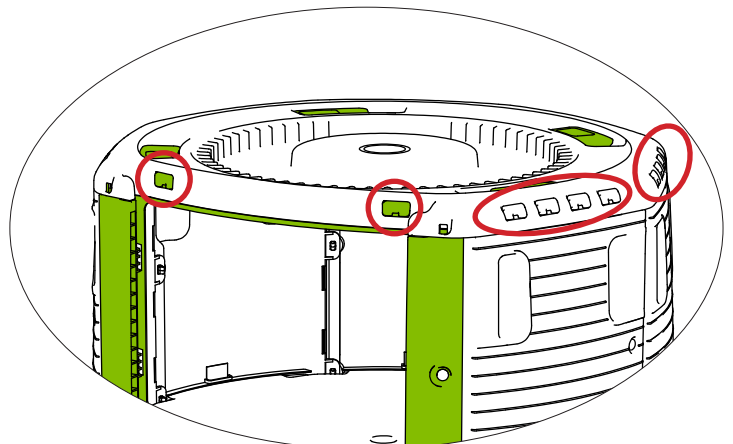
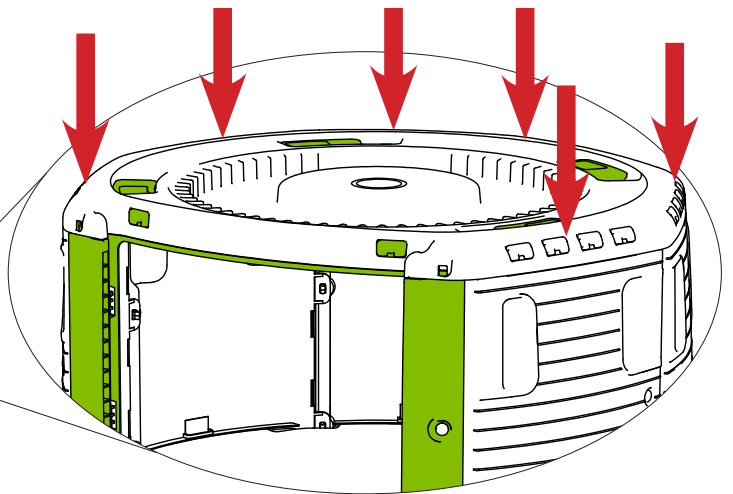
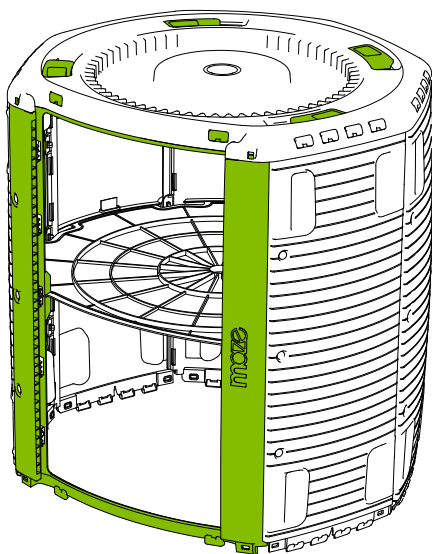

CHECK ALL PANELS ARE SECURELY
ENGAGED WITH THE END CAP.
ALL TABS SHOULD SIT FLUSH INTO THE
HOLES IN THE ENDCAP

STEP 8

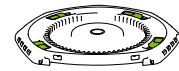

GD x 1

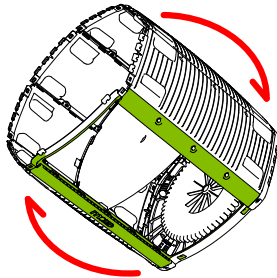

CAREFULLY FLIP BARREL AND REPEAT STEP 7 FOR OTHER END CAP

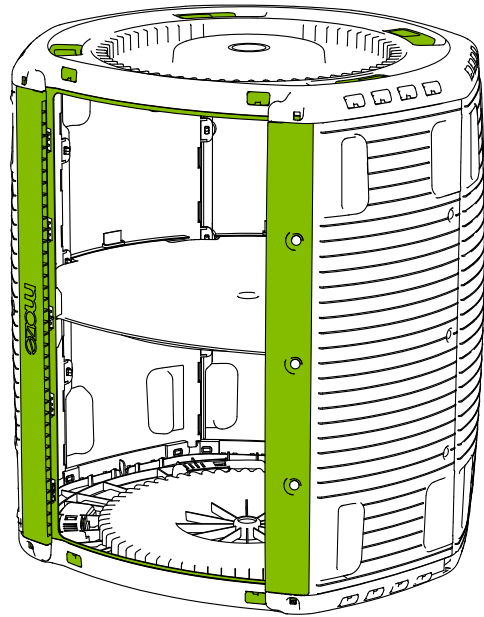
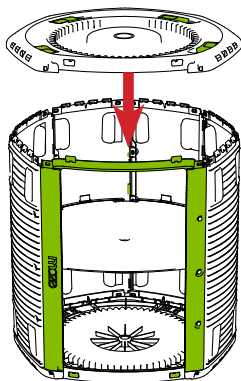

CHECK ALL PANELS ARE SECURELY ENGAGED WITH THE END CAP. ALL TABS SHOULD SIT FLUSH INTO THE HOLES IN THE ENDCAP

STEP 9



GAA x 4

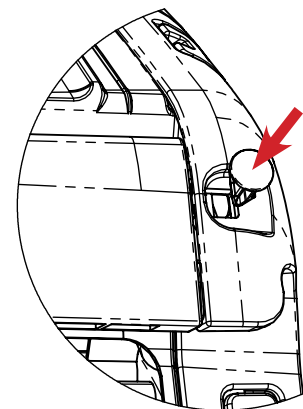
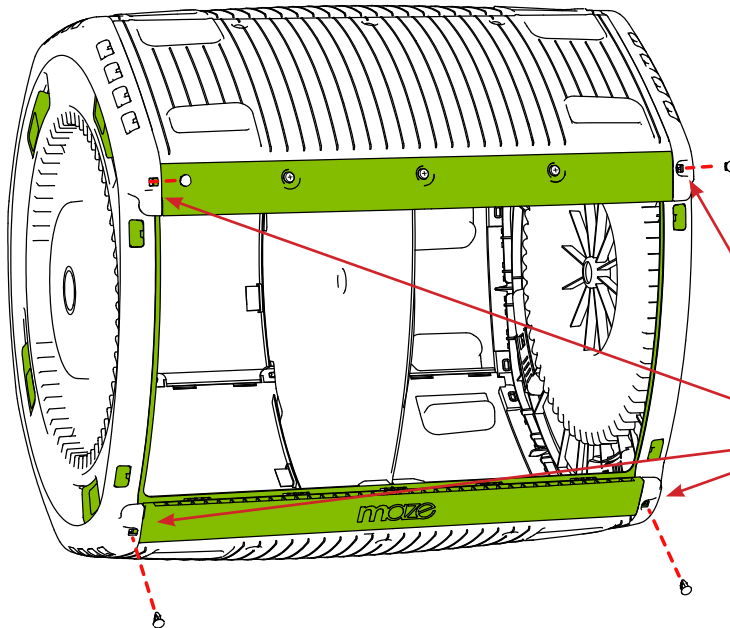

INSERT 4 SNAP CLIP INTO CORNER HOLES AS SHOWN IN DIAGRAM



ENSURE SNAP CLIPS ARE FULLY INSERTED

STEP 10

NOTE:
4MM ALLEN KEY REQUIRED

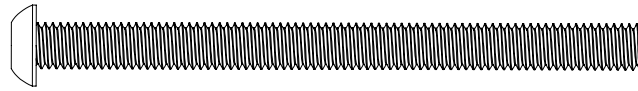

ACTUAL SIZE

GAB x 2

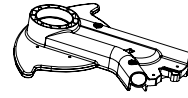

GO x 1



GP x 1



GQ x 1



GAE x 2



THESE NUTS ARE NYLOC AND ARE HARDER TO SCREW THAN REGULAR NUTS (TO ENSURE THEY DO NOT COME LOOSE)

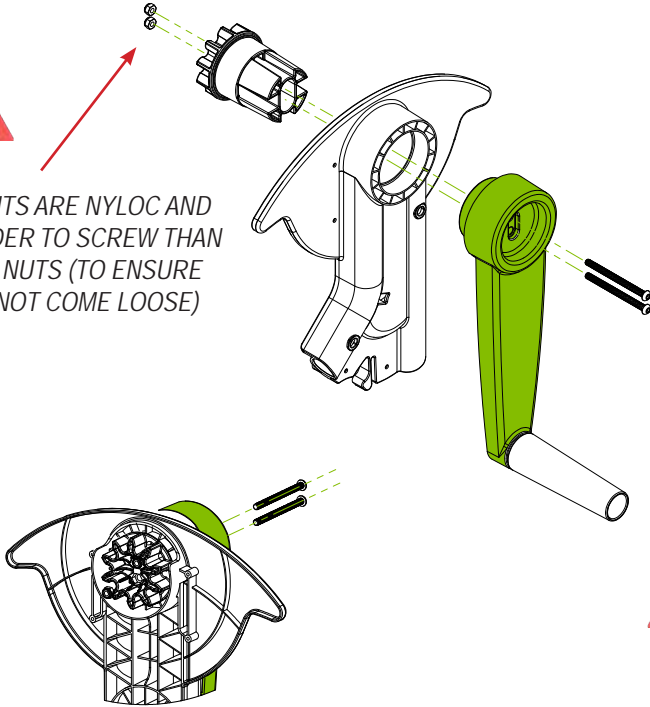

CHECK THAT HANDLE 'GQ' ROTATES FREELY IN THE HOUSING 'GO' BEFORE PROCEEDING

STEP 11

COMPRESS SILVER BUTTON ON 'GK' COMPONENT TO INSERT INTO HANDLE ASSEMBLY

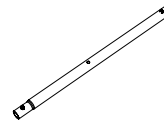

GK x 1

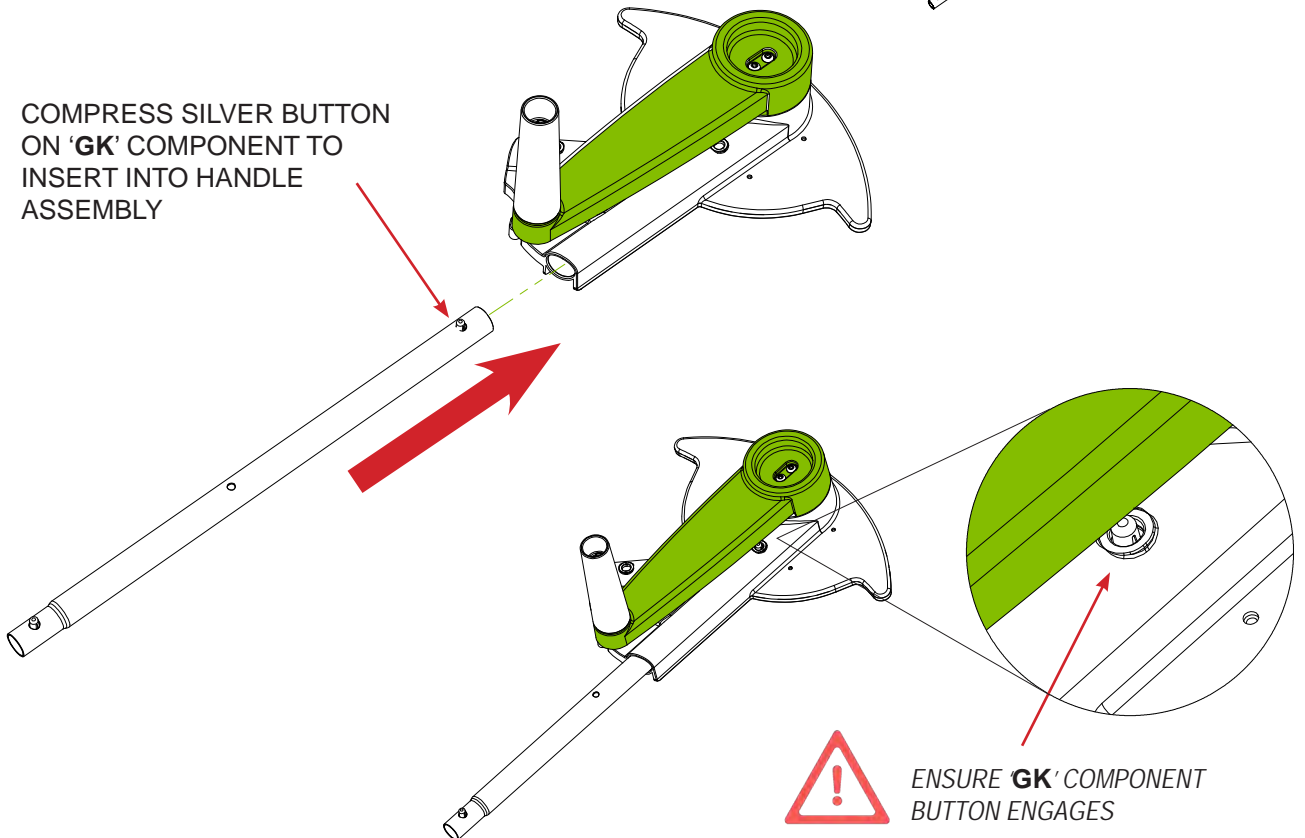

ENSURE 'GK' COMPONENT BUTTON ENGAGES

STEP 12

NOTE:
4MM ALLEN KEY
& 10MM SPANNER
REQUIRED

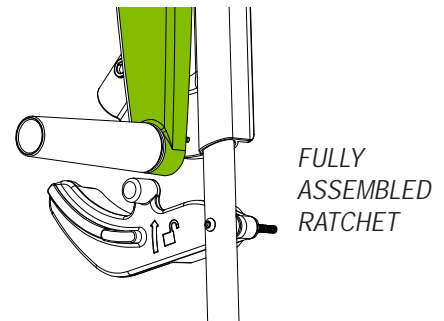
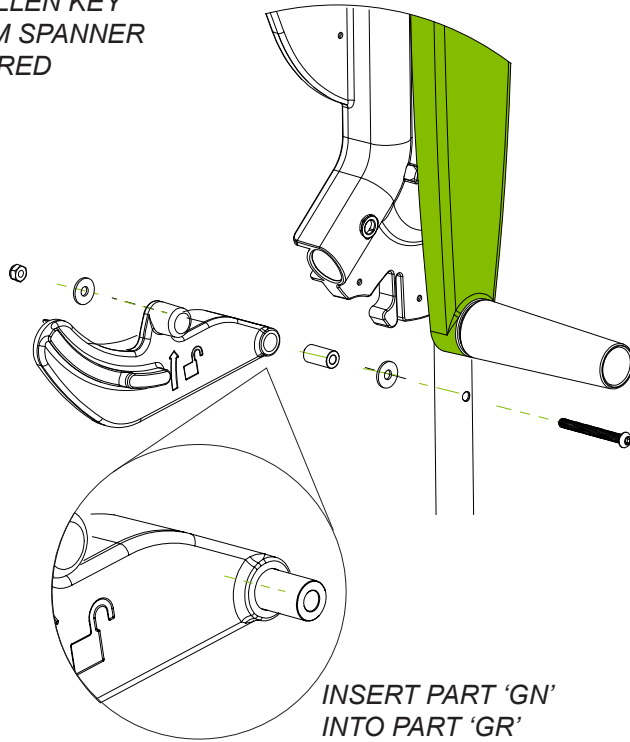
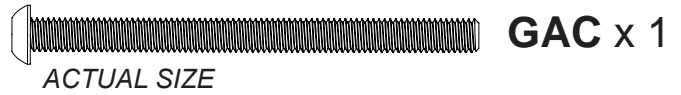

STEP 13

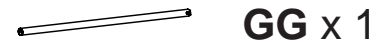

COMPRESS BUTTON ON
AXLE AND INSERT INTO
HANDLE ASSEMBLY

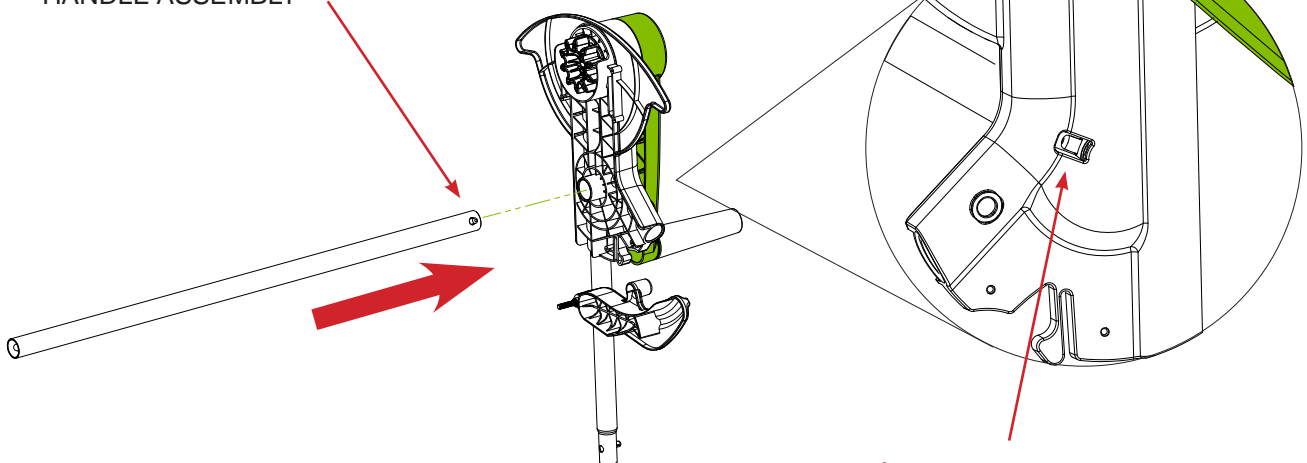

ENSURE SILVER BUTTON ON
AXLE IS ENGAGED INSIDE
THIS HOLE

STEP 14

SLIDE HANDLE ASSEMBLY INTO BARREL ASSEMBLY AS SHOWN.

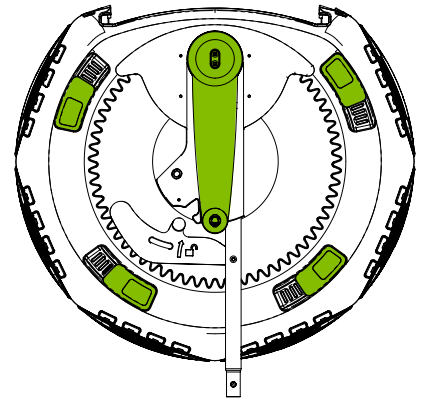
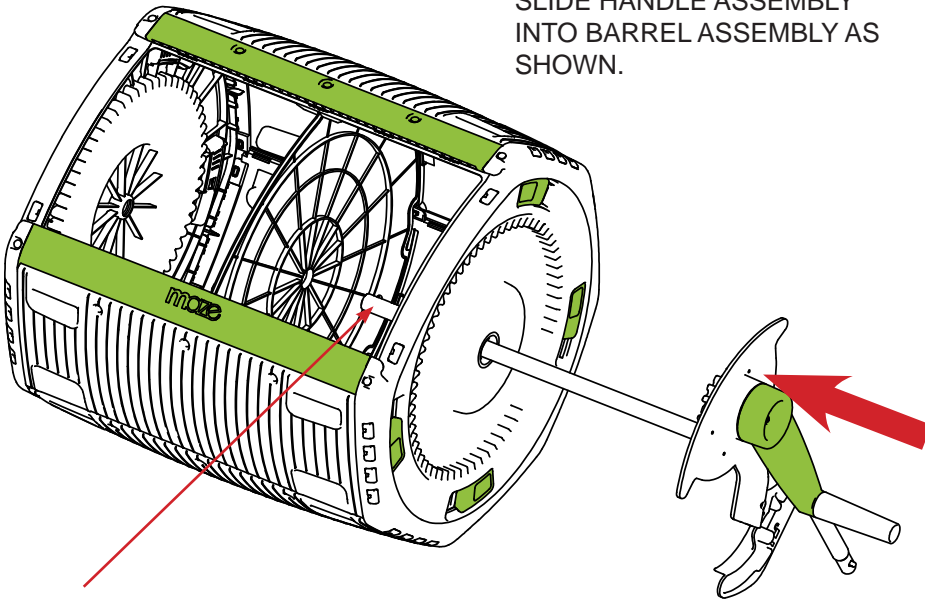

COG "GP" AND RATCHET "GR" SHOULD FIT INTO THE GEAR TEETH ON THE BARREL

TIP: COMPRESS BUTTON AS IT IS PUSHED THROUGH THE HOLE IN EACH PART

STEP 15



GM x 1

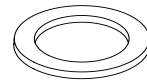

GAH x 1



PLACE **GAH** BARREL SPACER OVER THE CENTRAL TUBE ON PART **GM**

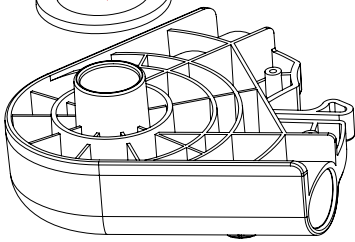

SLIDE COMPONENT "GM" (WITH GAH IN PLACE) OVER THE AXLE ON OPPOSITE SIDE OF BARREL



ENSURE **GAH** BARREL SPACER STAYS IN PLACE

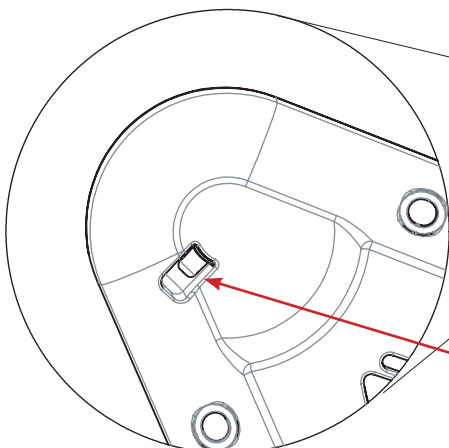

ENSURE AXLE BUTTON ENGAGES

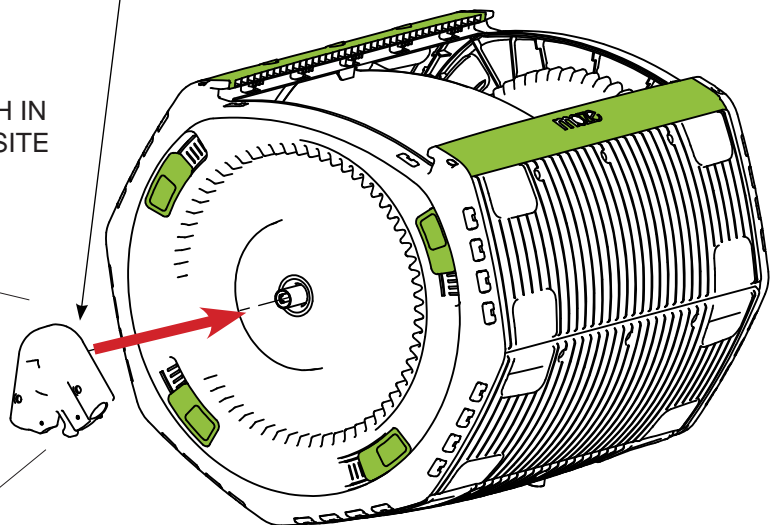

STEP 16

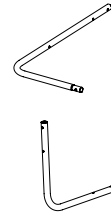
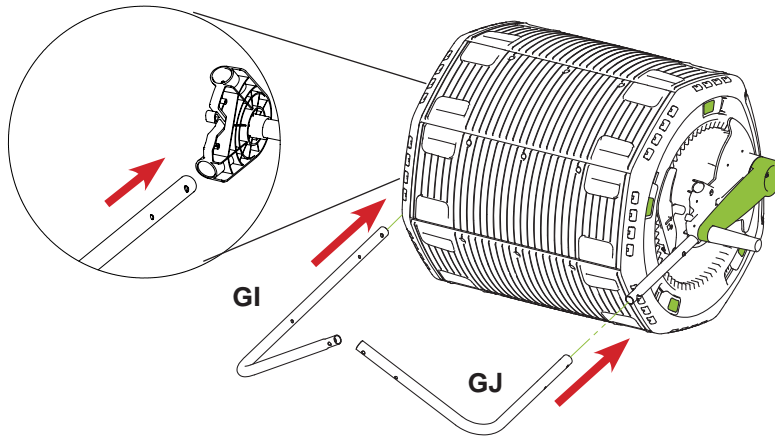

GI x 1

GJ x 1

1. INSERT BOTH LEG COMPONENTS AS SHOWN

2. PUSH AND ROTATE TOGETHER AS SHOWN

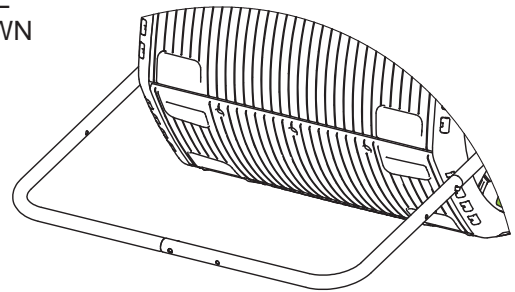
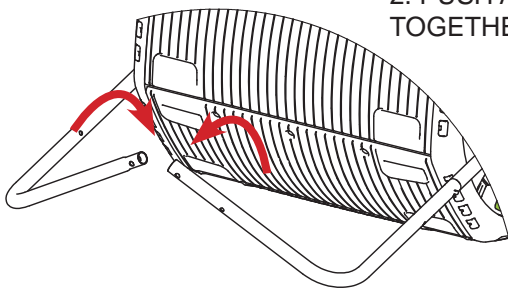

STEP 17

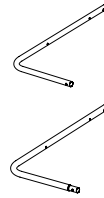
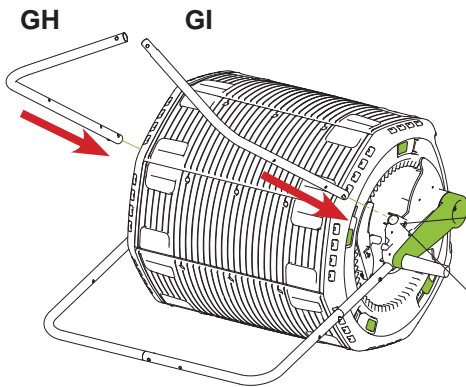

GH x 1

GI x 1

1. INSERT BOTH LEG COMPONENTS AS SHOWN

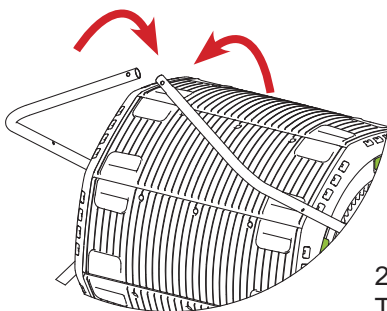

2. PUSH AND ROTATE TOGETHER AS SHOWN

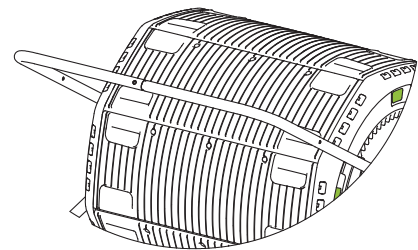

STEP 18

CAREFULLY ROTATE AND STAND COMPOSTER UPRIGHT

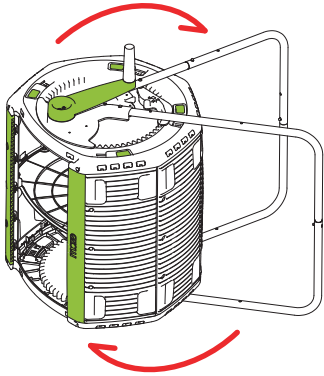

WARNING: WHEN LIFTING THE TUMBLER - BEWARE OF PINCH POINTS - AS THE TUMBLER MAY ROTATE AND CATCH YOUR FINGERS

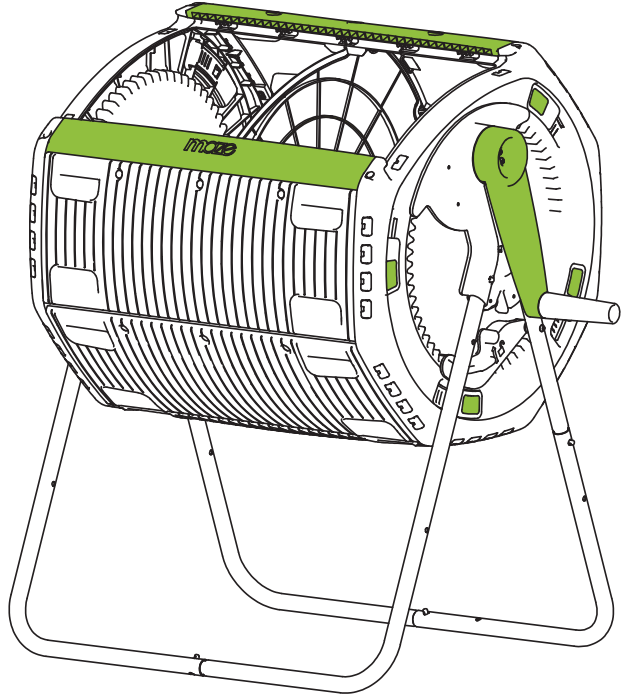

STEP 19

GL x 2

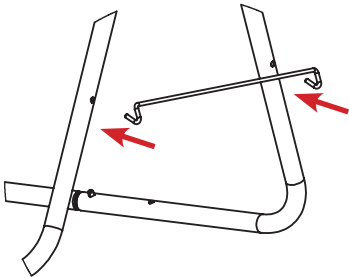

1. INSERT ENDS OF LEG BRACE INTO HOLE IN EACH LEG

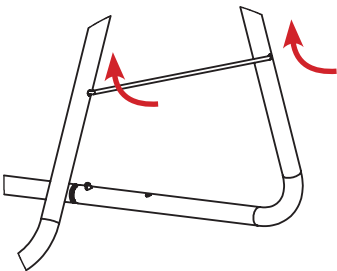

2. ROTATE LEG BRACE UP INTO HOLES SO THAT HORIZONTAL BAR SITS FLUSH AGAINST LEGS

3. REPEAT WITH SECOND BRACE AT OTHER END OF STAND

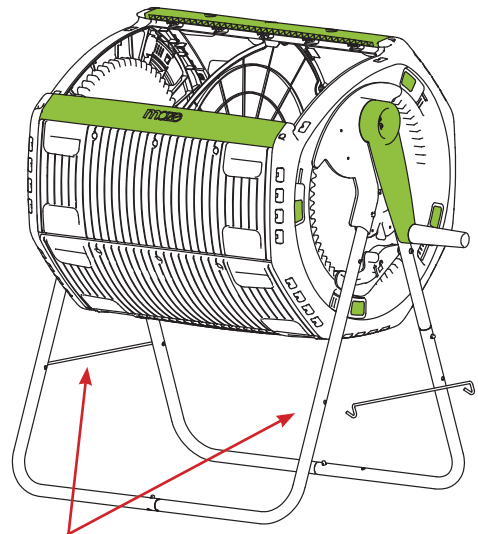

ENSURE BOTH LEG BRACES ARE FULLY INSERTED

STEP 20

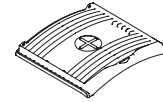

GE x 1

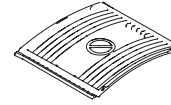

GF x 1

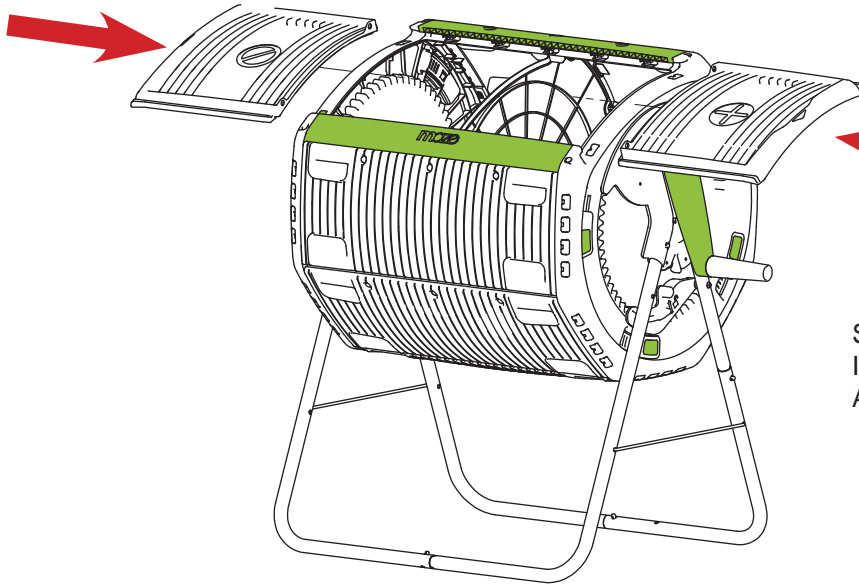

SLIDE DOOR COMPONENTS INTO THE MAIN BARREL ASSEMBLY AS SHOWN

ASSEMBLY IS COMPLETE

FEATURES:



SLIDING DOORS ARE INTERCHANGEABLE



TO KEEP DOOR CLOSED A PEG, CLIP OR PADLOCK CAN BE USED (NOT SUPPLIED)



INTEGRATED AIR VENTS CAN BE OPENED OR CLOSED.



UNLOCKING THE RATCHET ALLOWS THE BARREL TO ROTATE FREELY

TIP: IF MIXTURE IS TOO WET IT IS RECOMMENDED TO OPEN VENTS



WARNING: IT IS RECOMMENDED TO KEEP RATCHET ENGAGED AS OTHERWISE THE BARREL AND HANDLE CAN SPIN BACK AND CAUSE INJURY.

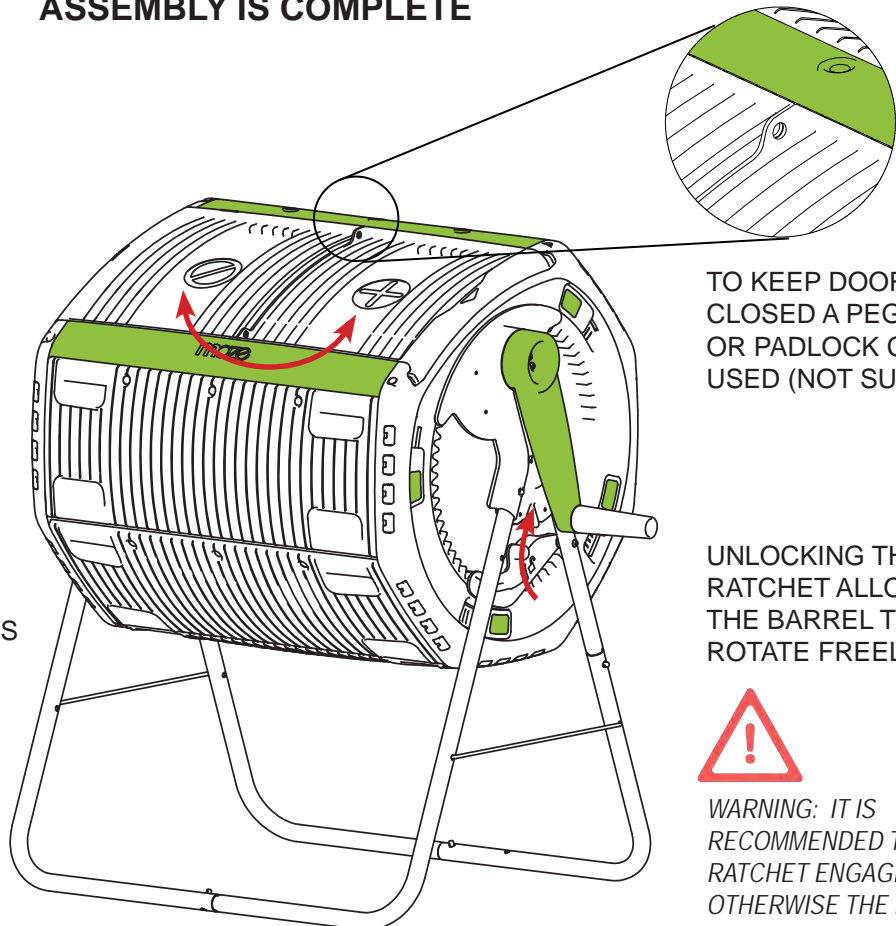

WARNINGS



WARNING:
BEWARE OF CATCHING
FINGERS IN GEARS

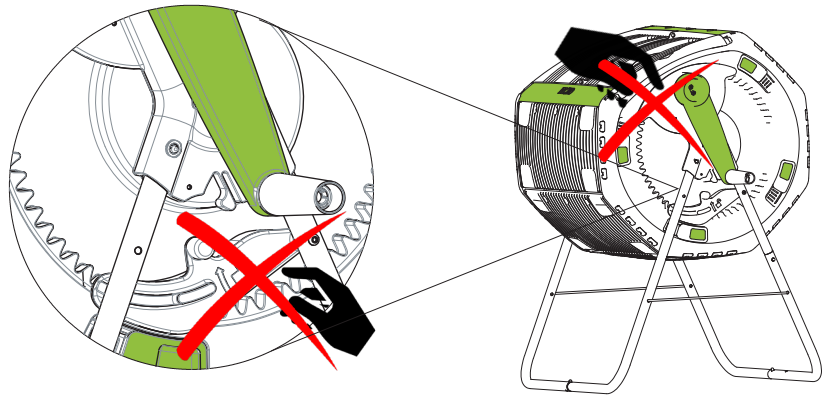

WARNING:
BEWARE OF CATCHING FINGERS IN DOORS

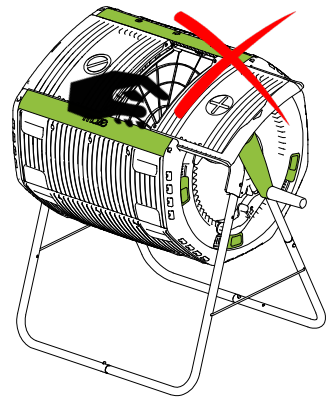

WARNING:
DO NOT ROTATE BARREL WITH DOORS OPEN

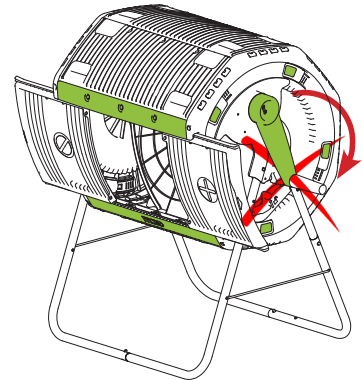

WARNING:
WHEN RATCHET IS UNLOCKED, STAND CLEAR
OF HANDLE AS IT MAY SPIN FAST OR IN THE
REVERSE DIRECTION

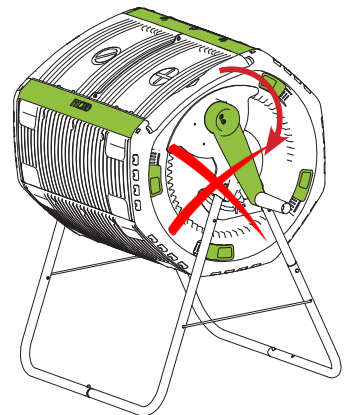

WARNING:
ALWAYS ENSURE COMPOSTER IS ON DRY, LEVEL GROUND

How to compost – Brief guide to get you started

1. Why compost?

Composting is a noble art with a very long history in sustainable food production. More and more, people are motivated by the desire for healthy soil, healthy food and a smaller environmental footprint. If all food waste was composted, food grown in our farms and gardens would be healthy, tasty and good to eat. Read more at mazingredients.com.au/composting

2. How to compost

Making compost is just like making a cake. We need the right ingredients in the correct proportions and mixed properly. We also need to get the moisture content and aeration right. But unlike making a cake, we don't have to be too precise about how we mix things. In simple terms, we are managing a balance between stuff that is easy to break down, and stuff that takes a bit longer. This is most easily understood by calling the easy-to-break-down stuff the 'green', and the harder-to-break-down stuff, the 'brown'. A 50/50 mixture of green to brown is a great place to start for successful composting. The ratio can be adjusted if compost is too wet or too dry.

Simple steps

1. Collect kitchen scraps in a kitchen caddy or indoor composter. It will speed things up if you chop this waste where possible.
2. Add the kitchen scraps to composter with some 'brown' scraps at similar time frames. Try to chop up or shred the brown waste as well if possible. If using the divided option start by adding to one half only. Use the door with the '+' symbol to remind you which side is being filled.
3. Turn the composter at least 2-3 times a week. When adding waste always give it a few turns.
4. Keep adding until full (or too hard to turn) ensuring to keep the consistency right. Once the first side is full, start filling the other compartment. Make sure to swap the doors so now the 'Ø' door is on the side that you just filled and the '+' is on the empty side.
5. You will know when the 'Ø' side is ready when the contents look and smell like soil. Once it is ready, rotate the opening to the bottom, place a bucket or Compost Cart under and then slide the door open to let the compost fall out. You may need to help it come out by using a trowel to scrape it out
6. Once empty swap the doors around again and start filling the empty side and repeat



3. What to compost

Table 1 below gives you an idea of what is green and what is brown. Table two gives you some idea of what else you can / cannot put into a compost. For best results chop or shred greens and browns before adding, and make sure the mix is moist, not wet.

Table 1. Green and Brown Compost Inputs

Green	Notes
Green leaves	Good to use
Grass clippings	Great addition when mixed well; can become smelly if not mixed
Green weeds	Avoid putting in seeds or runners
Fruit or vegetable scraps	Good to use
Cut flowers	Good to use but chop up into 100mm lengths before adding
Cooked food	No chunky meat, cheese or very oily wastes (e.g. fine meat or cheese like leftover spaghetti bolognaise is ok)
Cow, horse, pig, chicken manures (not dog or cat)	Good to use. Dog and cat manures can harbour diseases so best not to use.
Lucerne hay	Good to use
Blood and bone or dynamic lifter	Use only if you have too much 'brown' materials. Sprinkle lightly and make sure everything is kept moist.

Brown	Notes
Brown leaves	Good.
Dead grass or weeds	Good.
Paper and cardboard	Good
Mulch, Sawdust, Hay or Straw	Good to use if you have an imbalance of 'green'.

Table 2. Do's and Don'ts

Do not use:	Cooking oil, dog or cat manures, chunky meat or cheese, bones
OK to use:	Egg shells, wood ash, bread, milk or juice past its 'use by' date

Read more at mazingproducts.com.au/composting

4. How to use compost

This is where you get rewarded for your attention to your compost bin. Composting can take anywhere from 8 weeks to 24 weeks to mature and be ready to be applied to your garden. Compost that you buy from the hardware is usually quite fine because commercial composters screen the material before sale to remove the chunky bits.

You are encouraged to do the same as you will most likely find large particles such as twigs or mango or avocado stones still not broken down. It is a simple process to remove these by hand and put them back into the compost to continue breaking down.

Compost can be surface applied or dug into the soil. If you are applying compost to an established garden or under fruit trees, you really have no choice but to apply it to the surface as you can't easily dig it in. If you are applying compost to your vegetable garden, then you want to dig it in. read more at mazingproducts.com.au/composting

For more info, FAQs and troubleshooting visit mazingproducts.com.au/composting