

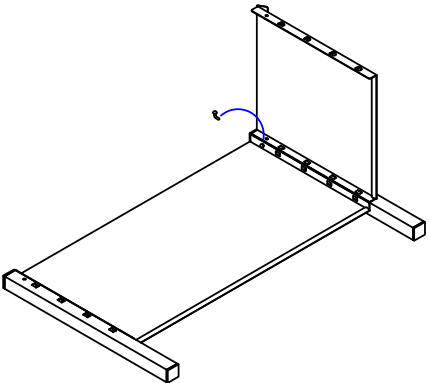

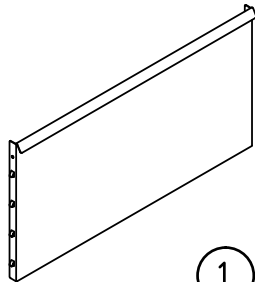
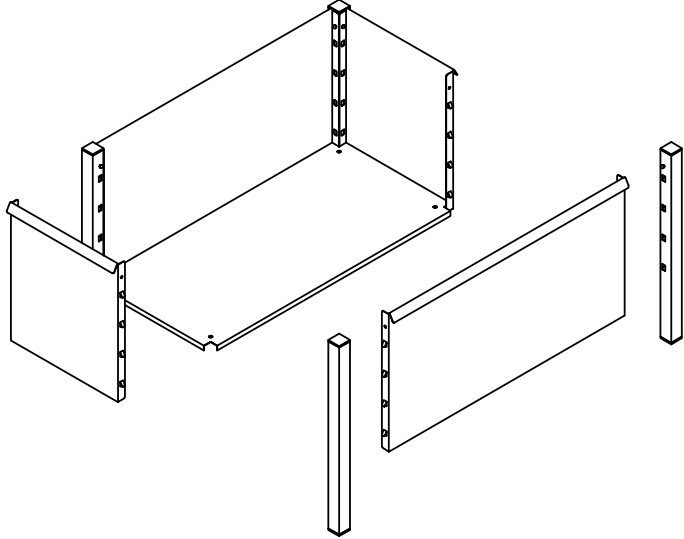
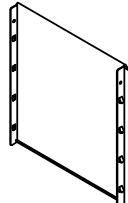
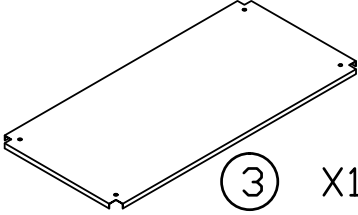
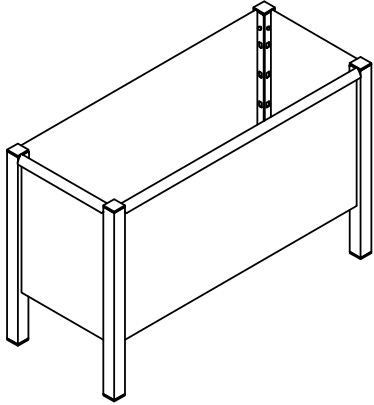

# ASSEMBLY INSTRUCTIONS

## GREENLIFE® SQUARE LEG PLANTER 600x250x380

	 <p>① X2</p>
	 <p>② X2</p>  <p>③ X1</p>
	 <p>④ X4</p>  <p>⑤ X8</p>  <p>⑧ X8</p>

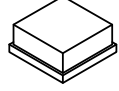
Follow us on Facebook, Twitter and Instagram! Share your garden pictures using the hashtag #GreenlifeAU



/greenlifegardenproducts



/GreenlifeAU



/GreenlifeAU