

Assembly Instructions

RVS40C & RVS70C

Please read instructions **COMPLETELY** prior to assembly

Caution

- Keep small children clear during assembly.
- Handle components with care due to sharp edges

Tools Required

- Rubber Mallet or Hammer

Helpful Hints

- Use a cloth or wooden block to protect the components when hammering.
- Hammer gently to avoid component damage.
- Drive rivets to the bottom of the keyhole by striking the beam near the joint.

Recommendations

- Wear gloves during assembly.
- Two persons assemble the unit.
- Assemble the unit on solid level surface.
- Heaviest items to be loaded on lower shelves.
- Loads to be evenly distributed.

Parts List

RVS70C

Uprights 915mm x 8 (A)

Long Low Profile Beams 915mm x 18 (D)

Short 3 Rivet Beams 305mm x 2 (E)

Long 3 Rivet Beams 910mm x 2 (E)

Long High Profile Beams 910mm x 4 (B)

Short High Profile Beams 300mm x 4 (C)

Melamine Shelves 11 x 16x292x908mm

Melamine Shelf* 1 x 16x292x902mm

Plastic Bins Narrow (100mm) x 40 (120 x Dividers)

Plastic Bins Wide (160mm) x 30 (90 x Dividers)

Plastic Upright End Caps x 8 (F)

*** This shelf is shorter than the rest. It goes in the middle of the unit where the uprights join together.**

RVS40C

Uprights 915mm x 4 (A)

Long Low Profile Beams 915mm x 8 (D)

Long High Profile Beams 910mm x 4 (B)

Short High Profile Beams 300mm x 4 (C)

Melamine Shelves 16mm x 6

Plastic Bins Narrow (100mm) x 40 (120 x Dividers)

Plastic Upright End Caps x 8 (F)

Assembly

Step 1 - Unpack the unit, confirm that you have all the parts listed.

Step 2 - Join two uprights with short high profile beam. Working from the bottom leave one upright keyhole vacant and join using keyholes two & three as shown in Diagram 1. The beam rivets locate in the upright keyholes

NOTE: It is important that you orientate all beams so that the flat part of the shelf ledge is facing up.

Diagram 1

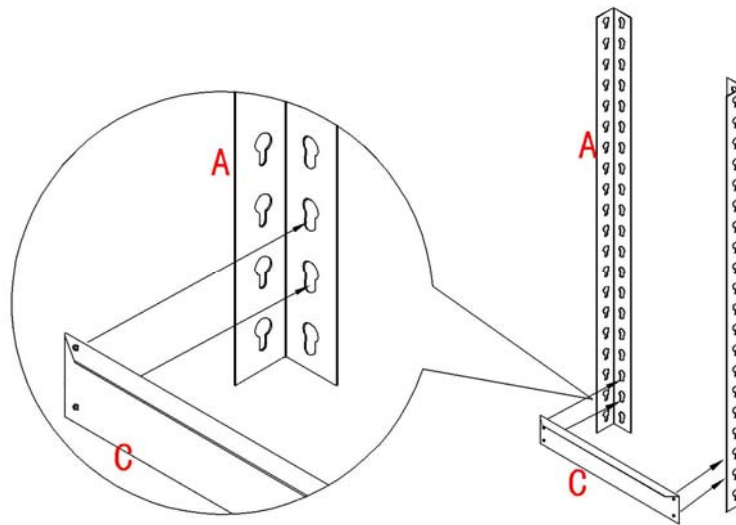

Step 3 - Join third upright with long high profile beam. Working from the bottom leave one upright keyhole vacant and join using keyholes two & three as shown in Diagram 2.

Diagram 2

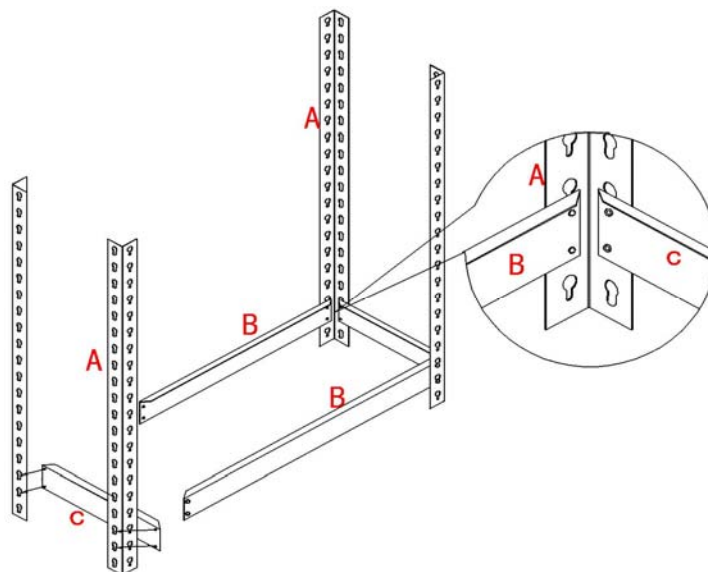

Step 4 - Join remaining fourth upright with long high profile beam and short high profile beam. Working from the bottom leave one upright keyhole vacant and join using keyholes two & three as shown in Diagram 2. **At this stage you can begin putting the melamine shelves in at each level. It is easier to put the shelves in as you build then it is to go back and put them in after.**

Step 5 - Working up, leave 3 keyholes vacant, join 1 x long low profile 2 rivet beam between the uprights as shown in Diagram 3. This is the front of the unit. Remember to orientate the beams so that the flat part of the shelf ledge is facing up.

Diagram 3

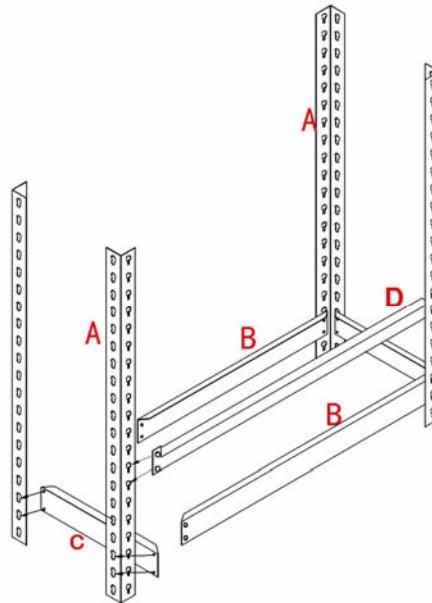

Step 6 - Working up, leave three keyholes vacant, join 1 x long low profile beam between the uprights with 'L Profile' down as shown in Diagram 4. This is the back of the unit.

Diagram 4

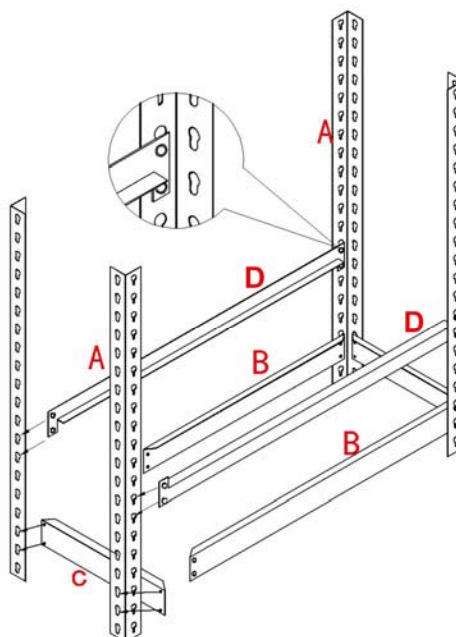

Step 7 - Working up, repeat Steps 5 & 6 (three times) Leave two keyholes vacant between each beam.

FOR RVS40C ONLY

Step 8 - Fit the remaining two short and two long high profile beams in the top upright keyholes as shown in Diagram 5.

Diagram 5

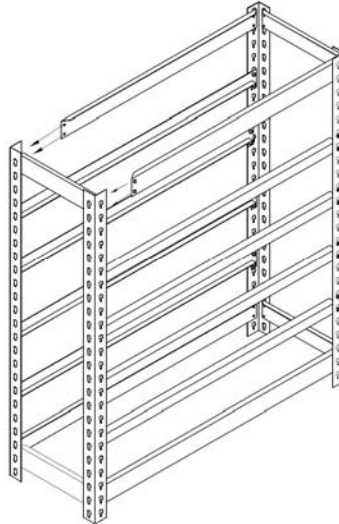

FOR RVS 70C ONLY (steps 9 to 11)

Step 9 - Fit the two short low profile 3 rivet beams and two long low profile 3 rivet beams to join remaining 4 uprights as shown in Diagram 6. The 3 rivet beams should have 1 rivet attached to the top 4 uprights and 2 rivets attached to the bottom 4 uprights.

Diagram 6

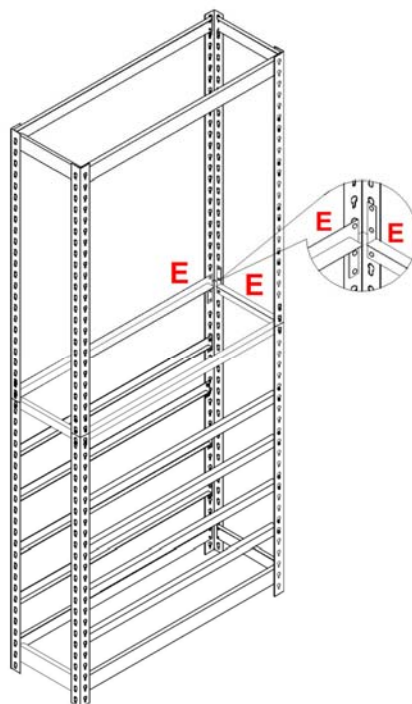

Step 10 – Working up repeat steps 5 & 6 (five times) Leave one keyhole vacant above the 3 rivet beams and then two keyholes vacant between each beam for the remainder.

Step 11 - Fit the remaining two short and two long high profile beams in the top upright keyholes.

Step 12 - Fit the shelves as shown in Diagrams 7 & 8.

NOTE: The middle shelf for the RVS70C is shorter than the rest and will only fit in that particular location.

Diagram 7
RVS40C

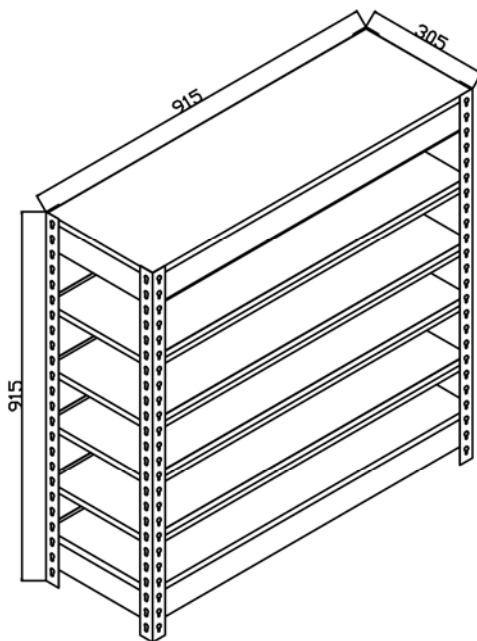

915H*915W*305D

Diagram 8
RVS70C

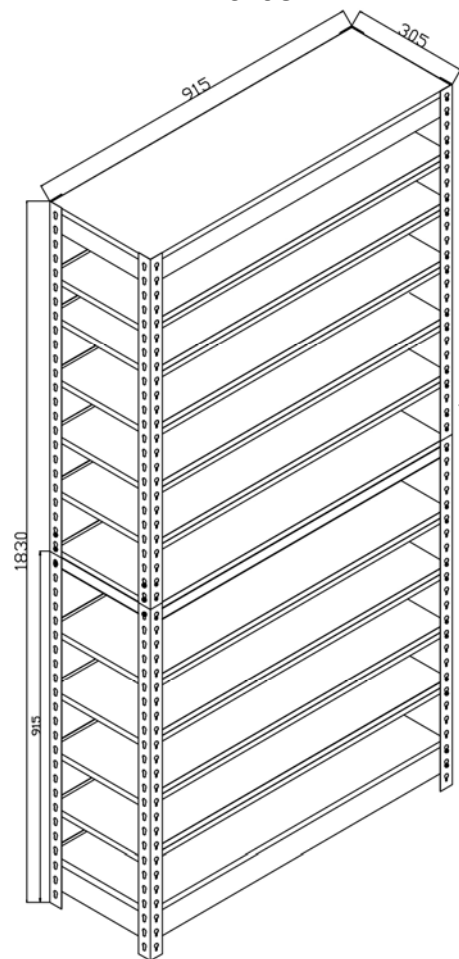

1830H*915W*305D

Step 12 - Fit the 8 x end caps to the uprights as shown in Diagram 9.

Diagram 9

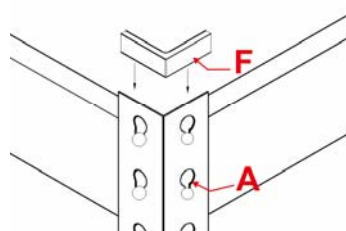

Step 13- Fit dividers to the plastic bins and load plastic boxes onto shelves in the desired locations.