

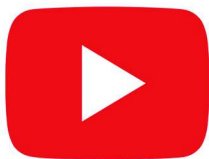

The following instructions will detail how to assemble the Maze Compost Tumbler. It should take around 2-4 hours to put the compost bin together. If you have any problems during the assembly feel free to contact our office during office hours. You can visit our website to watch a instructional video on the assembly process.



Visit our website to see more information including an assembly video <http://www.mazeproducts.com.au/product/maze-compost-tumbler-245lt/> (in VIDEO tab)









If you encounter missing or broken parts please visit our website and click on the spare parts link (in PRODUCTS heading) to order the parts





Share the love:







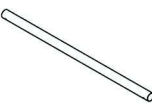
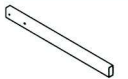
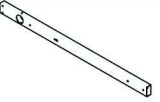
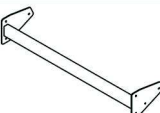
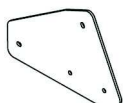

Thank you for buying our product. We would love it if you wrote a quick product review by visiting the product page on our website and leaving your feedback.





Your review will help other customers make more informed decisions about our products before they buy them. - and you'll go in the monthly draw for a \$100 voucher for any item on our Ah-maze-ing website :)

INCLUDED COMPONENTS



PART	PART NUMBER	QTY	DESCRIPTION
	AA	35 +2 SPARE	BUTTONHEAD SOCKET SCREW M5x16
	AB	4	BUTTONHEAD SOCKET SCREW M5x25
	AC	16 +1 SPARE	BUTTONHEAD SOCKET SCREW M5x40
	AD	6	BUTTONHEAD SOCKET SCREW M5x55
	AE	2	BUTTONHEAD SOCKET SCREW M5x70
	AF	1	OVERSIZED M5 WASHER
	AG	30 +2 SPARE	SELF CLINCHING NUT M5
	AH	13 +1 SPARE	NYLOC NUT M5
	AI	20	BARREL NUT M5x20

PART	PART NUMBER	QTY	DESCRIPTION
	G	1	SLIDING DOOR -TIME
	H	1	SLIDING DOOR -PLUS
	I	1	AXLE
	J	2	LEG BOTTOM
	K	2	LEG VERTICAL
	L	1	STAND BASE
	M	2	STAND BRACKET
	N	2	BARREL SPACER

PART	PART NUMBER	QTY	DESCRIPTION
	AJ	1	END CAP CHS 38mm
	AK	5	END CAP RHS 25x50mm
	AL	1	NYLON SPACER
	A	1	DOOR PANEL
	B	4	PANEL
	C	1	CAP -NO HOLES
	D	1	CAP -HOLES
	E	2	DIVIDER
	F	4	INTERNAL GEAR

PART	PART NUMBER	QTY	DESCRIPTION
	O	1	INNER GEAR COG
	P	1	CRANK COVER
	Q	1	CRANK ARM
	R	1	CRANK HANDLE
	S	1	CRANK RACHET

TOOLS PROVIDED:

	8MM SPANNER
	3MM ALLEN KEY

TOOLS REQUIRED:

	FLATHEAD SCREWDRIVER
---	----------------------

STEP 1

TIP: IN THESE INSTRUCTIONS WE HAVE SUGGESTED THE BEST WAY TO POSITION THE PARTS AND THE BARREL. PLEASE TRY TO FOLLOW AS PER THE DIAGRAMS.

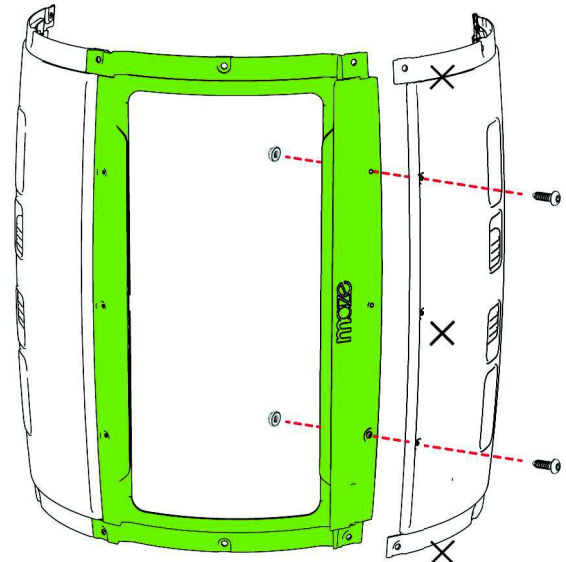
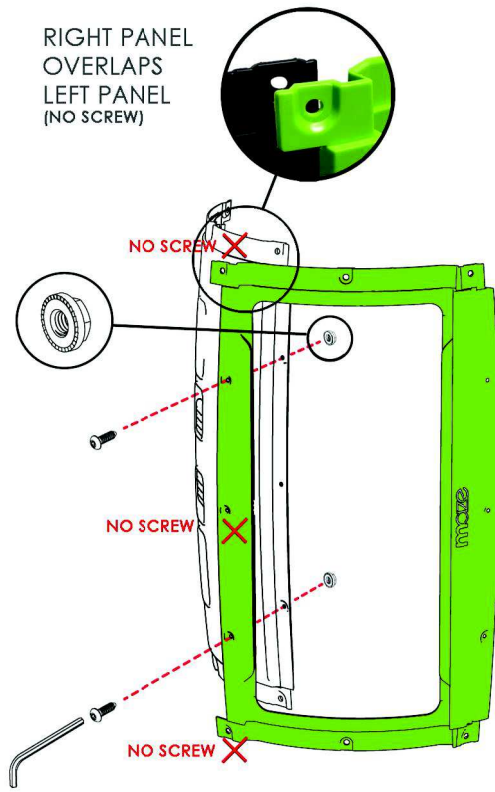
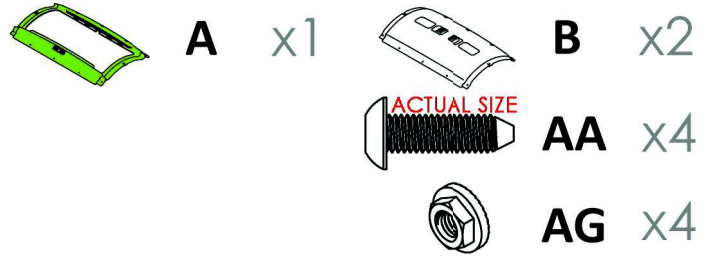

USE ALLEN KEY TO TIGHTEN SCREWS IN PLACE

STEP 2

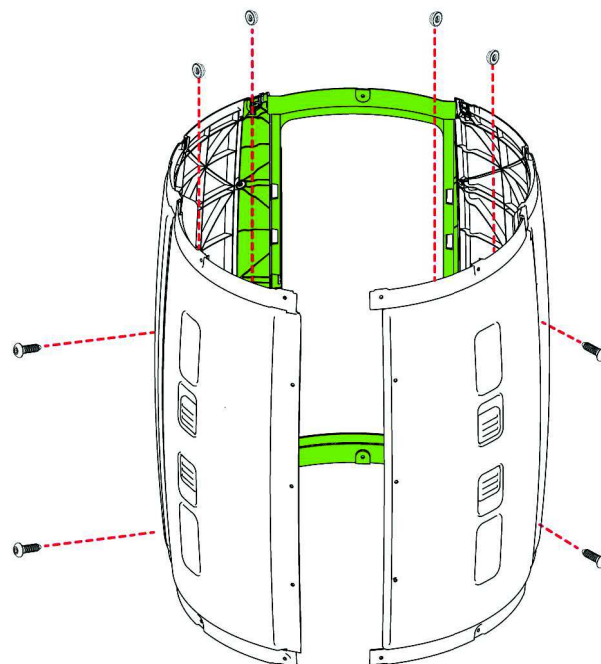
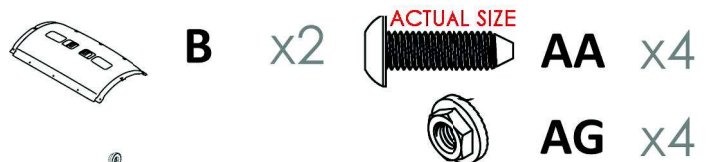

ENSURE TO LEAVE THE BACK PANELS OPEN

STEP 3



E x2



AA x4



AG x4

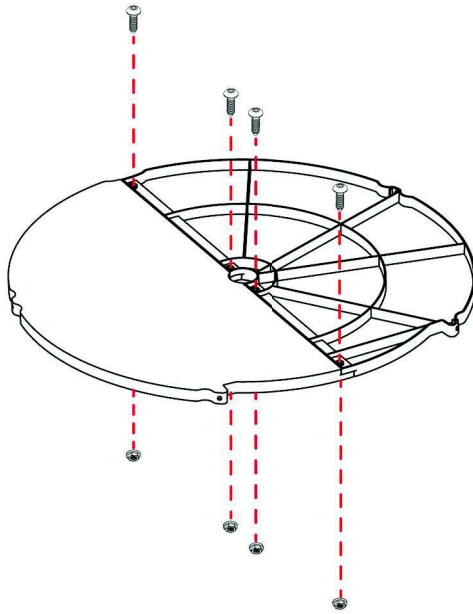

STEP 4



AB x2



AG x2

TIP: THE SLOT FOR THE NUT IS DESIGNED TO HOLD IT IN PLACE TIGHTLY. IF IT DOESN'T SLIDE IN, TURN IT SLIGHTLY.

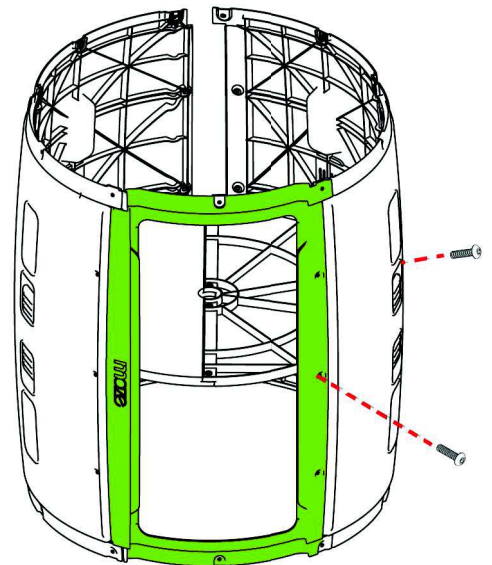
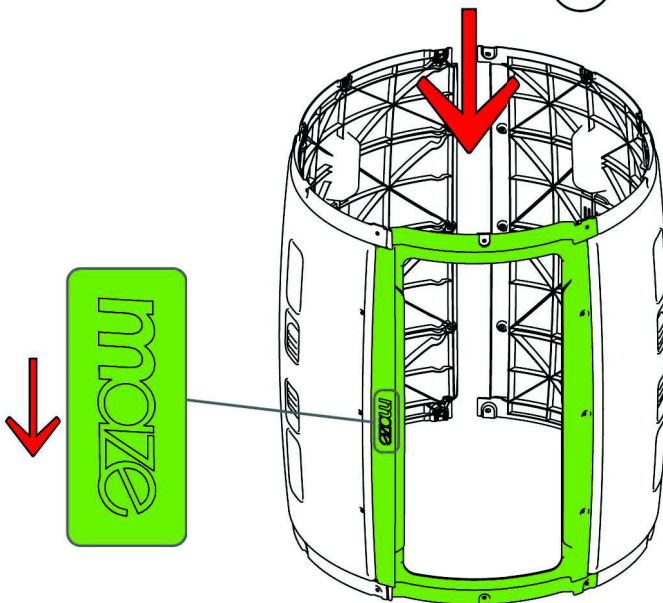
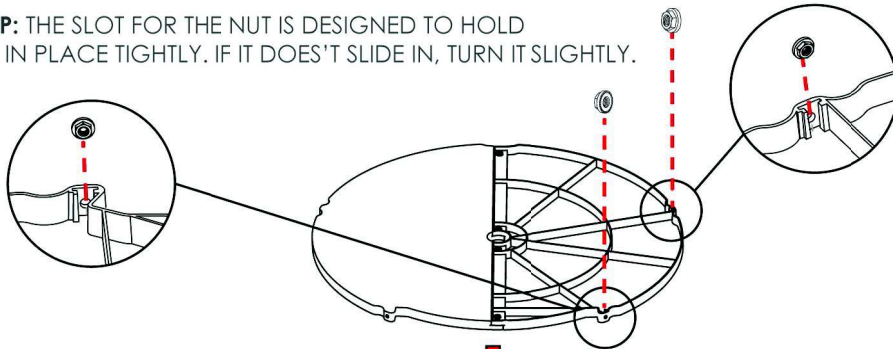

TIP: WHILE INSERTING THE SCREWS YOU MAY FIND IT EASIER TO HOLD THE DIVIDER (PART E) IN PLACE FROM THE HOLE IN THE MIDDLE OF THE DIVIDER.

STEP 5

ENSURE NUTS DROP STRAIGHT INTO SLOTS

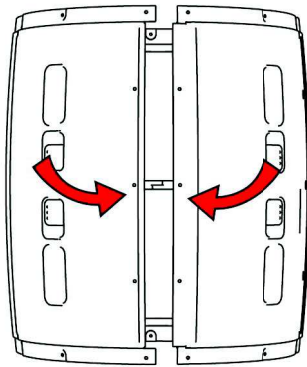
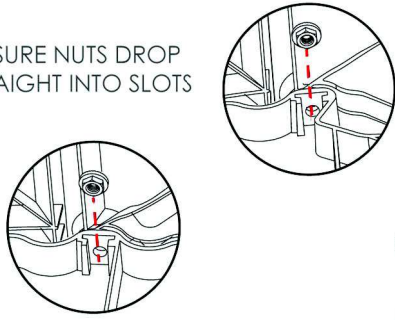
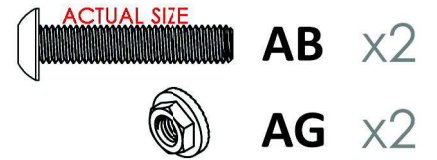

SQUEEZE PANELS TOGETHER

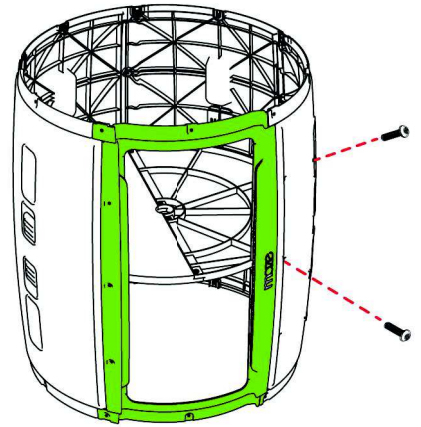

FLIP BARRELL OVER CAREFULLY

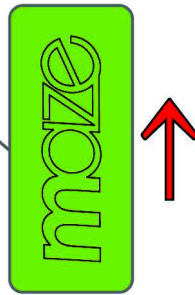

STEP 6

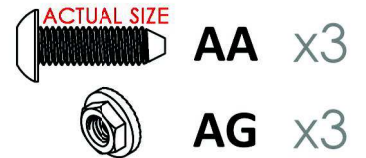

FLIP BARRELL OVER CAREFULLY

TIP: YOU MAY FIND IT EASER TO PLACE THE NUT IN THE SPANNER HOLE AND MOVE IT INTO POSITION **OR** PUSH THE DIVIDER DOWN SLIGHTLY TO HOLD THE NUT WITH YOUR HAND

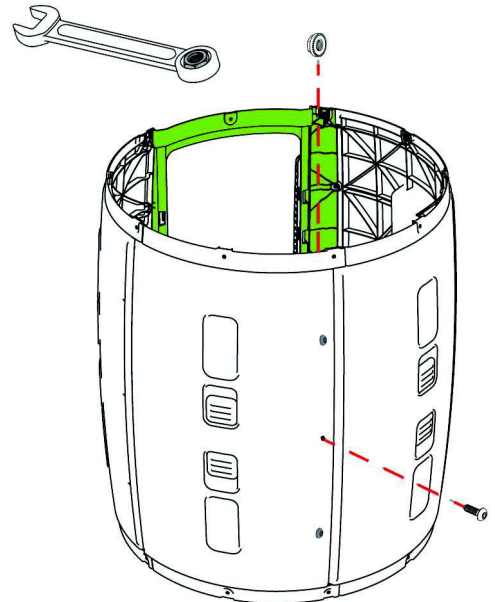
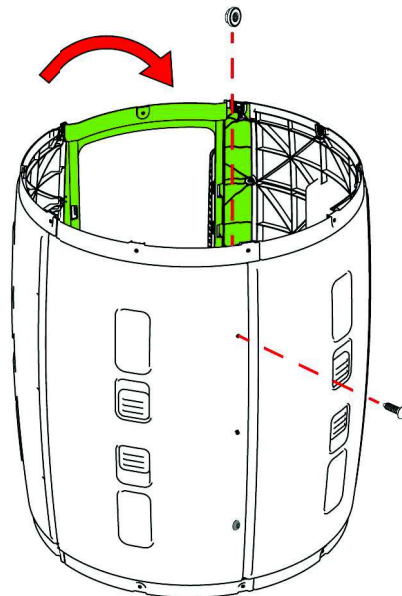
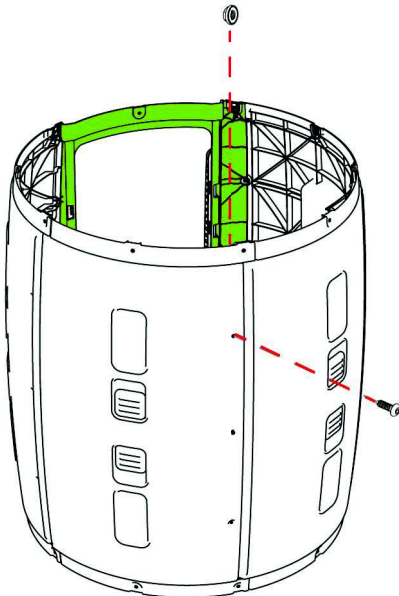

STEP 7

SELECT THE PART WITH THE EXTRA HOLES AS BELOW (NOT PART C)

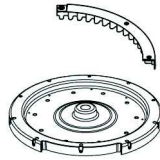

F x4

D x1



AC x8



AG x8

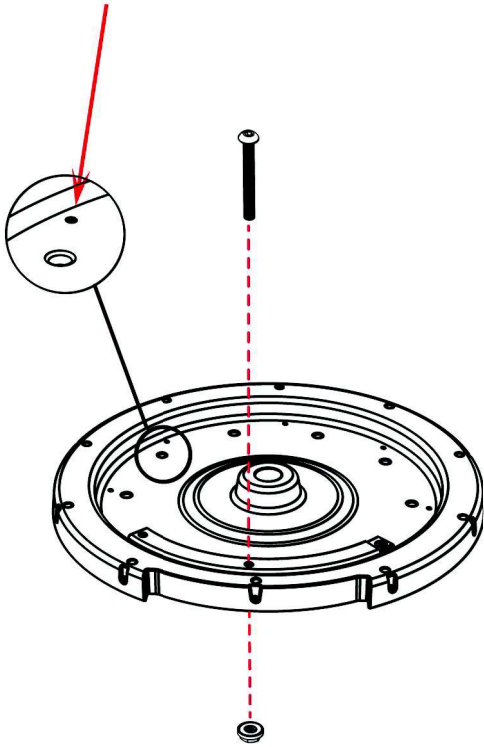

LOCATE PART F AS SHOWN, ASSEMBLE MIDDLE BOLT FIRST

ATTACH BOLTS AT JOINTS BETWEEN GEARS FIRST THEN REMAINING 3 BOLTS

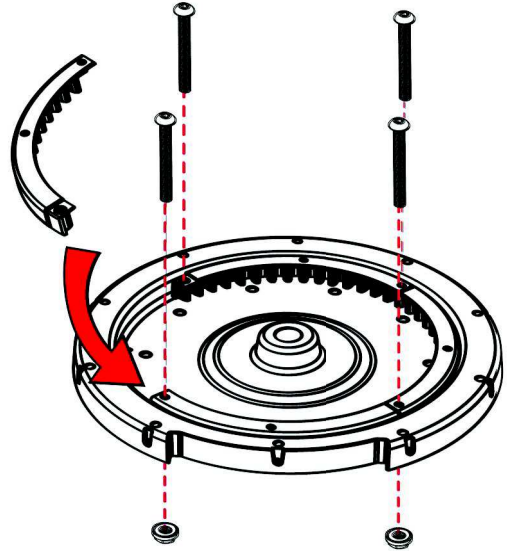

STEP 8

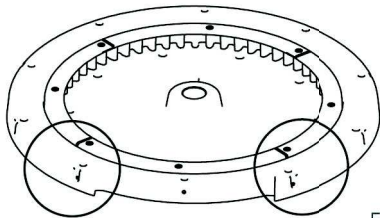

FASTEN PART D TO BARREL IN THESE TWO LOCATIONS FIRST (AS CIRCLED)



AA x10



AI x10

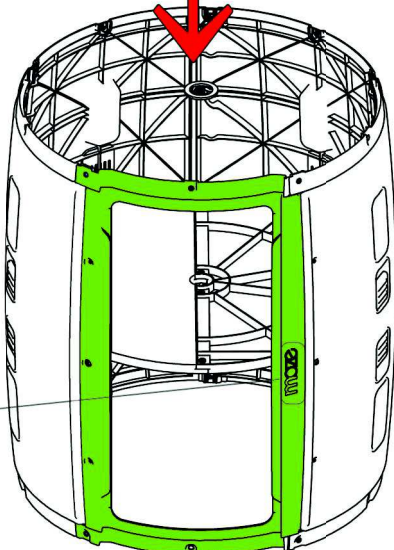
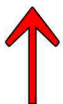

TIP: INSERT THE BARREL NUT SO INDENTED LINE IS FACING UP. THEN USE A SCREWDRIVER TO ALIGN THE DIRECTION OF THE THREADED HOLE.

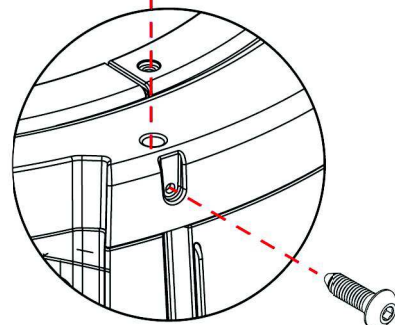

STEP 9

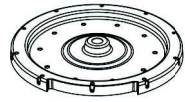

C x1



ACTUAL SIZE

AA x10



AI x10

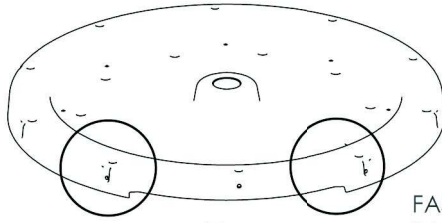

FASTEN PART C TO BARREL
IN THESE TWO LOCATIONS
FIRST (AS CIRCLED)



TIP: INSERT THE BARREL NUT SO
INDENTED LINE IS FACING UP.
THEN USE A SCREWDRIVER TO
ALIGN THE DIRECTION OF
THE THREADED HOLE.

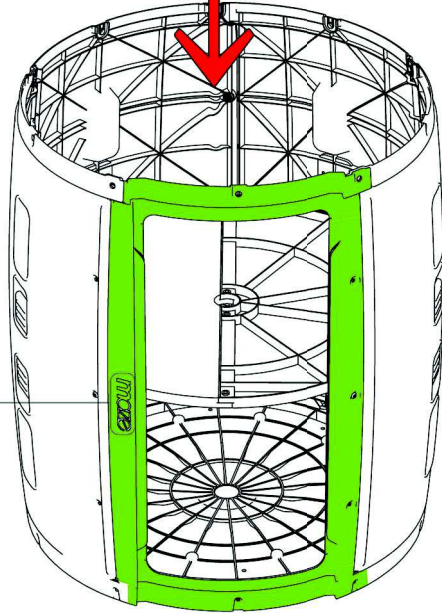
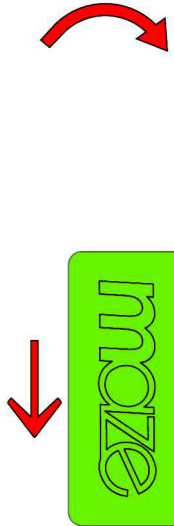

FLIP BARRELL OVER **CAREFULLY**

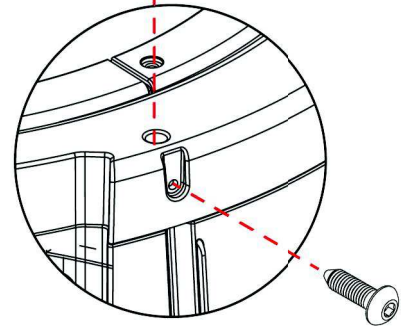

STEP 10



ACTUAL SIZE

AE x2



AH x2



O x1



P x1



Q x1



R x1

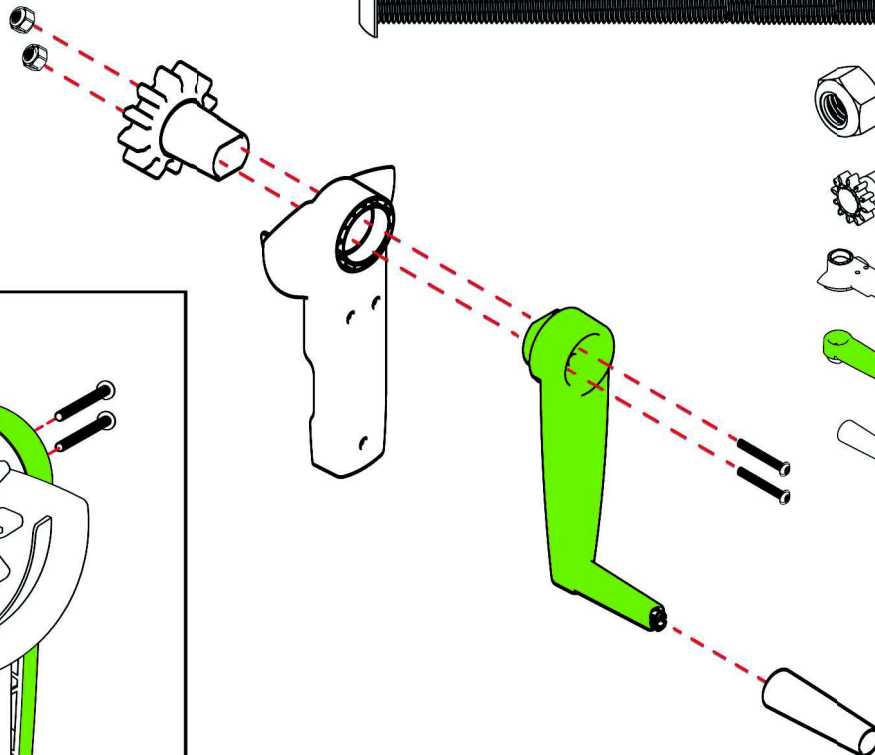
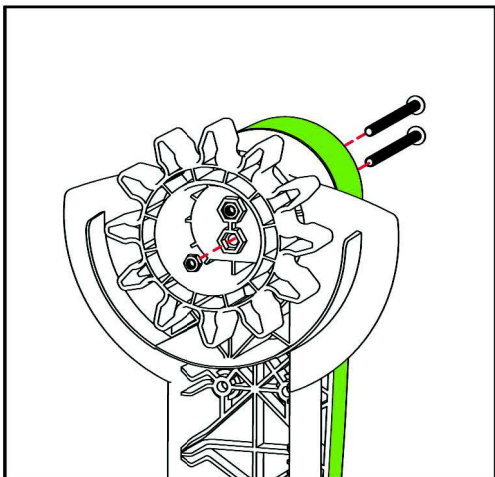

STEP 11

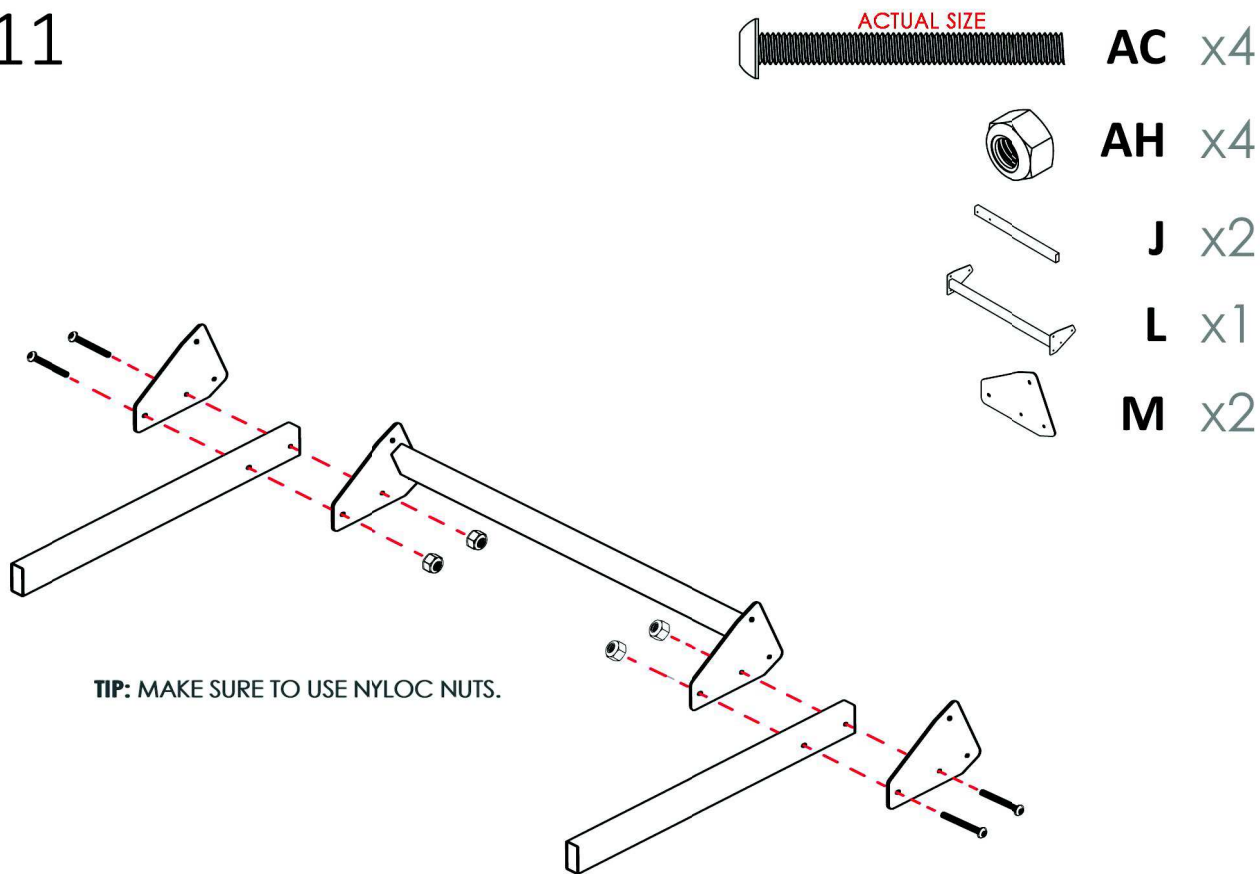

STEP 12

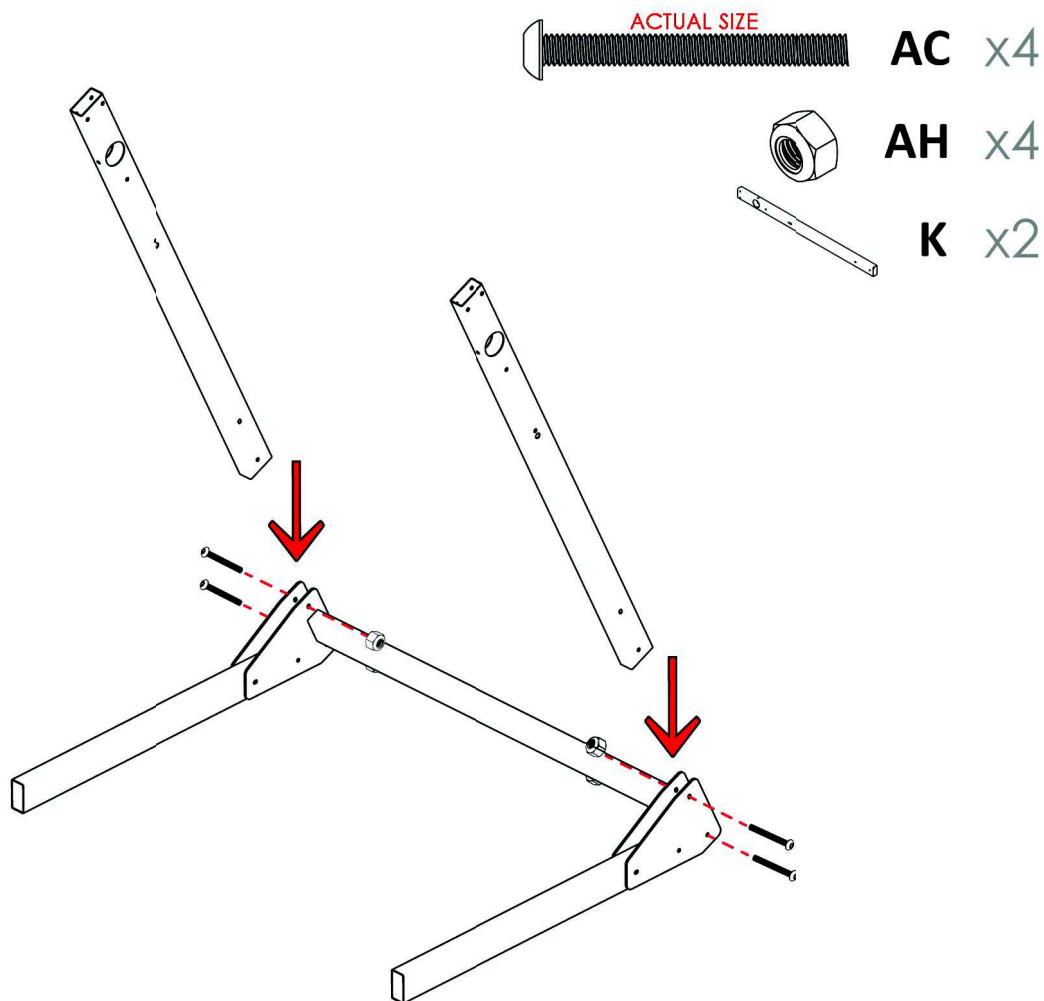

STEP 13

 **AK** x4

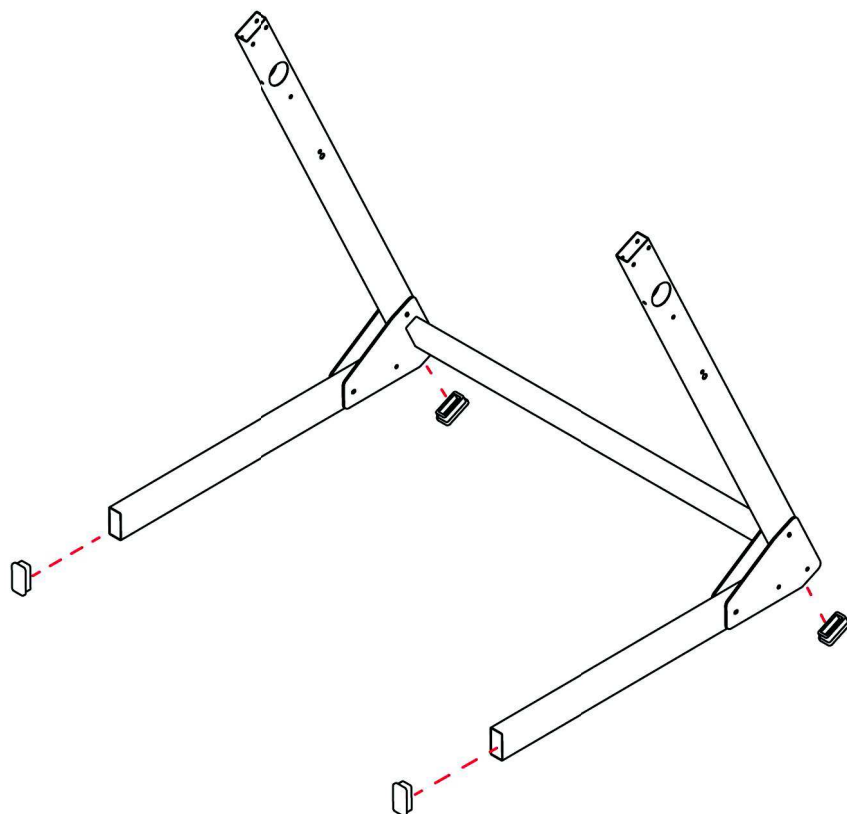

STEP 14

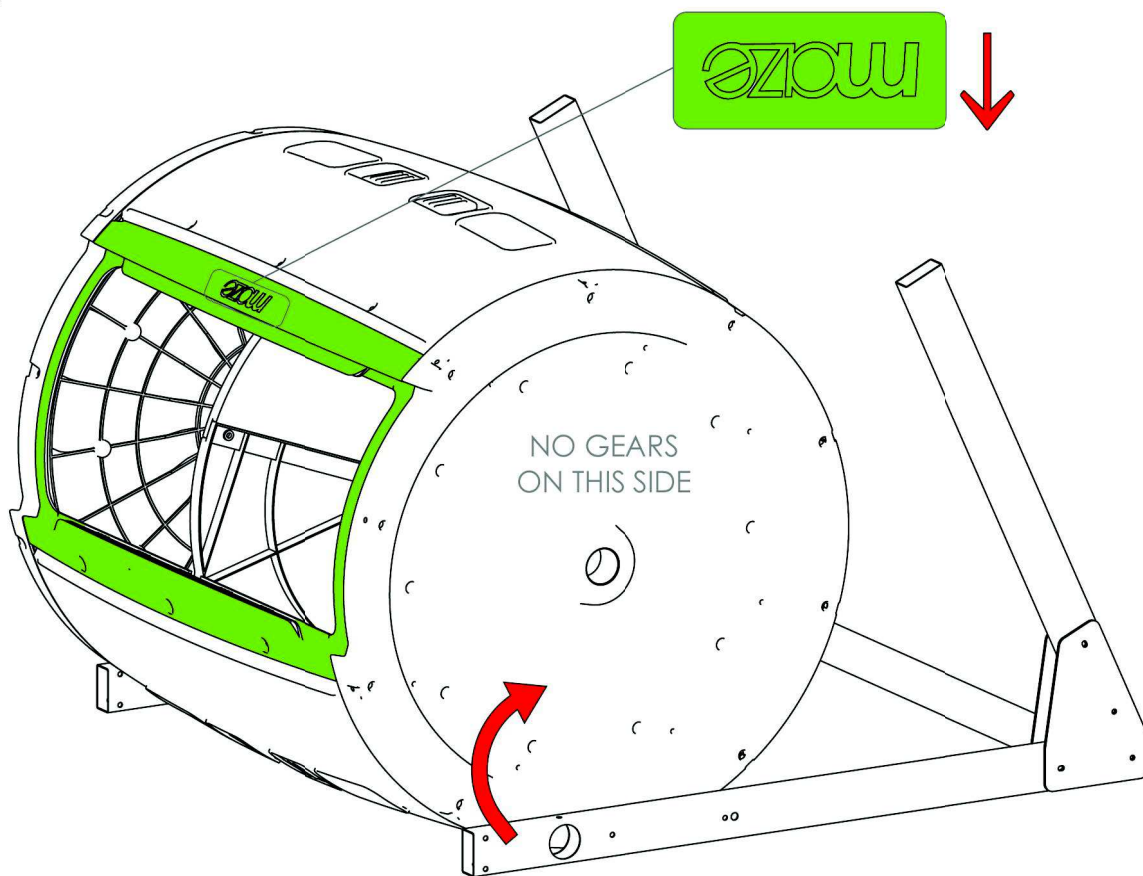

STEP 15

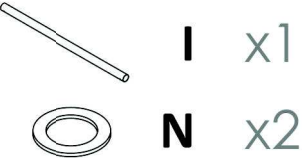

THREAD BARREL SPACERS (PART N) ONTO AXLE (PART I)
BARREL SPACERS SHOULD SIT BETWEEN THE BARREL
AND STAND ON BOTH SIDES.

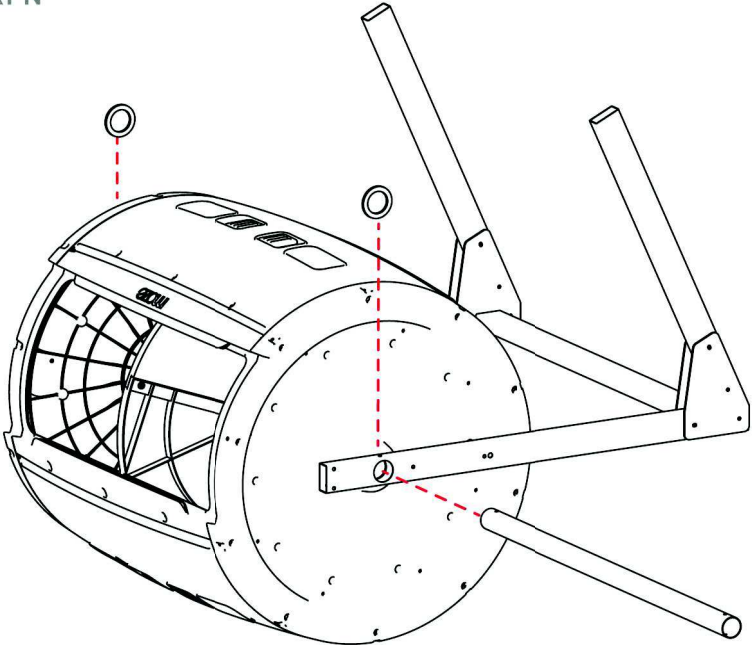
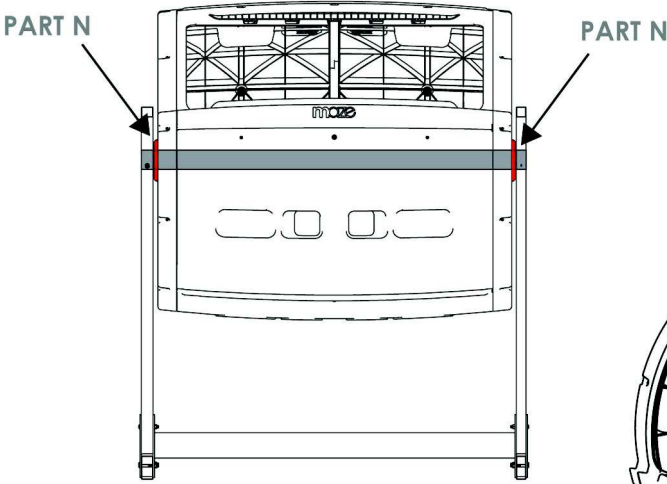

STEP 16

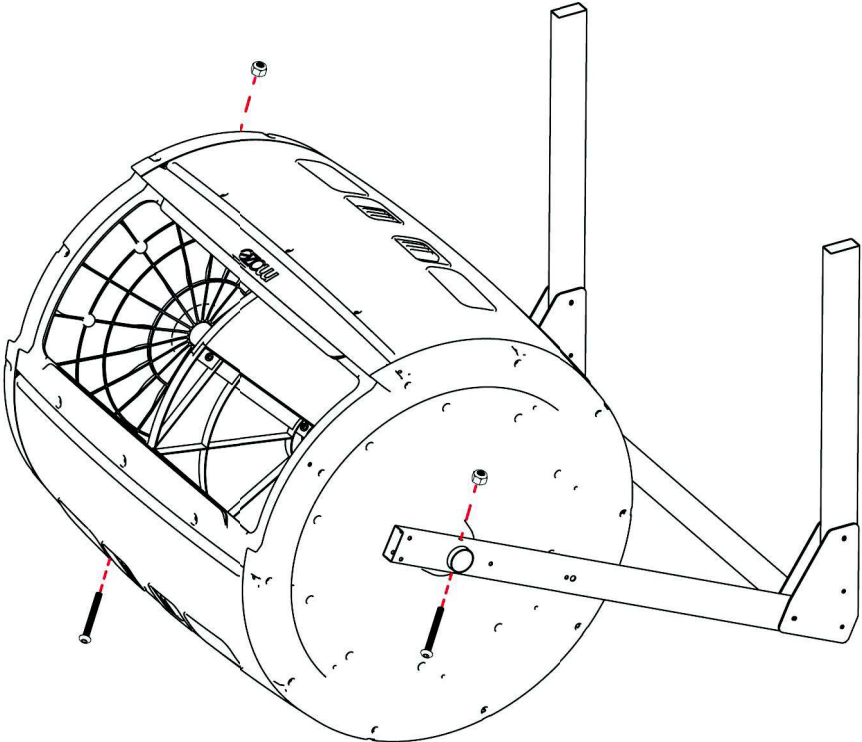

STEP 17

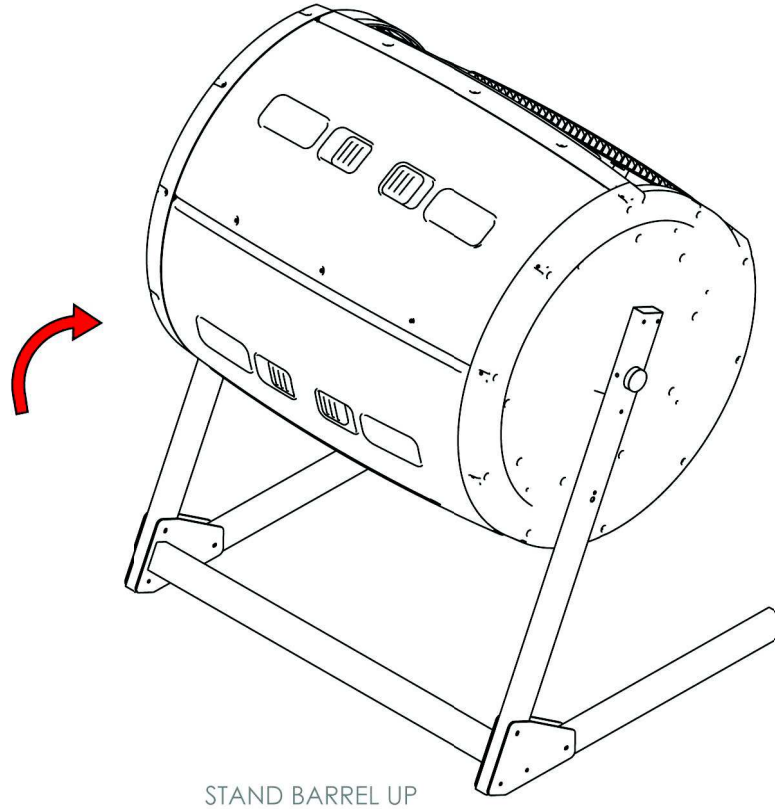

STAND BARREL UP

STEP 18

TIP: ALIGN THE DOOR OPENING WITH THE ANGLE OF THE STAND, AS IN THE BELOW DRAWING. THIS WILL ENSURE THE HANDLE IS NOT IN THE WAY OF THE DOOR OPENING.

AS ASSEMBLED IN STEP 10



x1

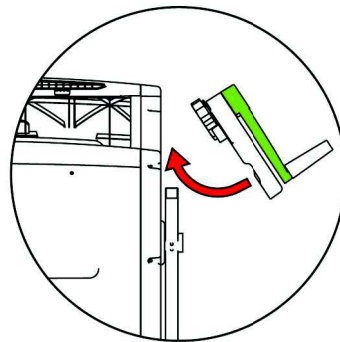
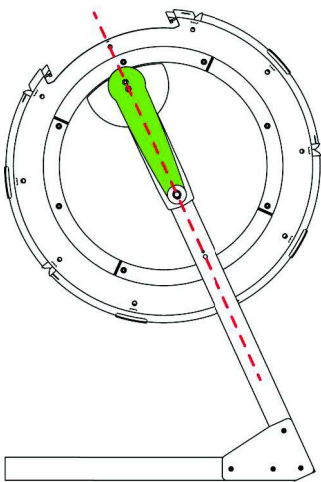

ARM ASSEMBLY MUST BE INSERTED ON AN ANGLE

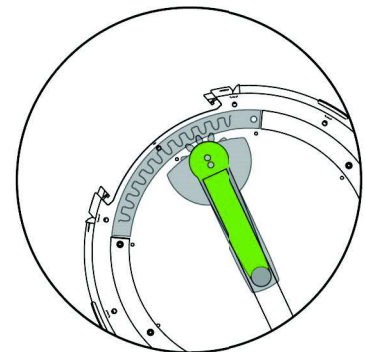
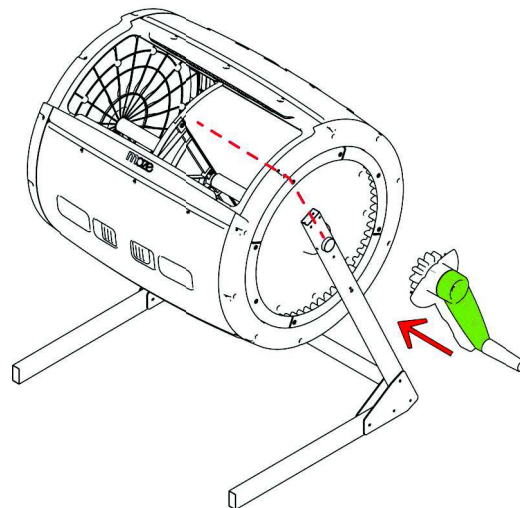

GEAR TEETH IN ARM SHOULD FIT INTO GEAR TEETH ON BARREL

THE PLASTIC COVER WILL FIT OVER THE STAND

STEP 19

TIP: YOU SHOULD BE ABLE TO REACH THE NUTS (DIFFERENT ONES TO THE LAST STEPS) AND HOLD THEM IN POSITION UNTIL THEY REACH THE STAND AND WILL SELF TIGHTEN



TIP: MAKE SURE TO USE THE SELF CLINCHING NUTS

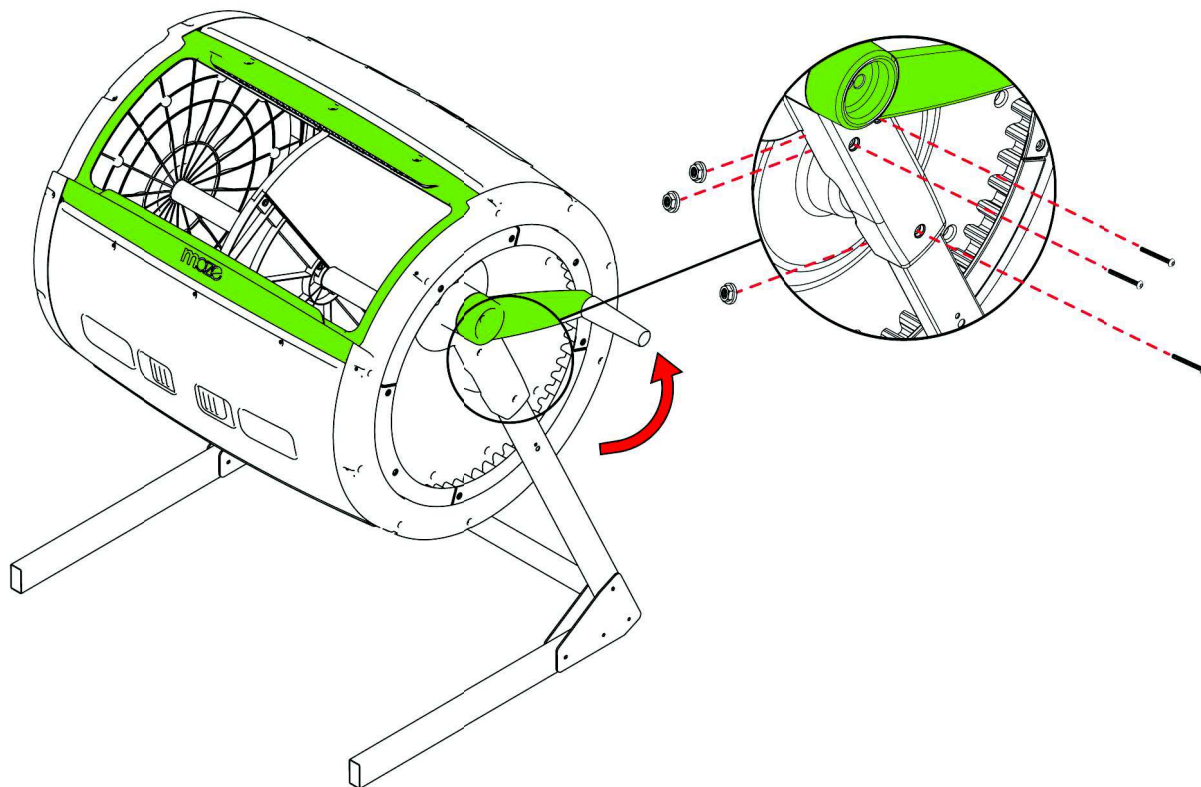

STEP 20

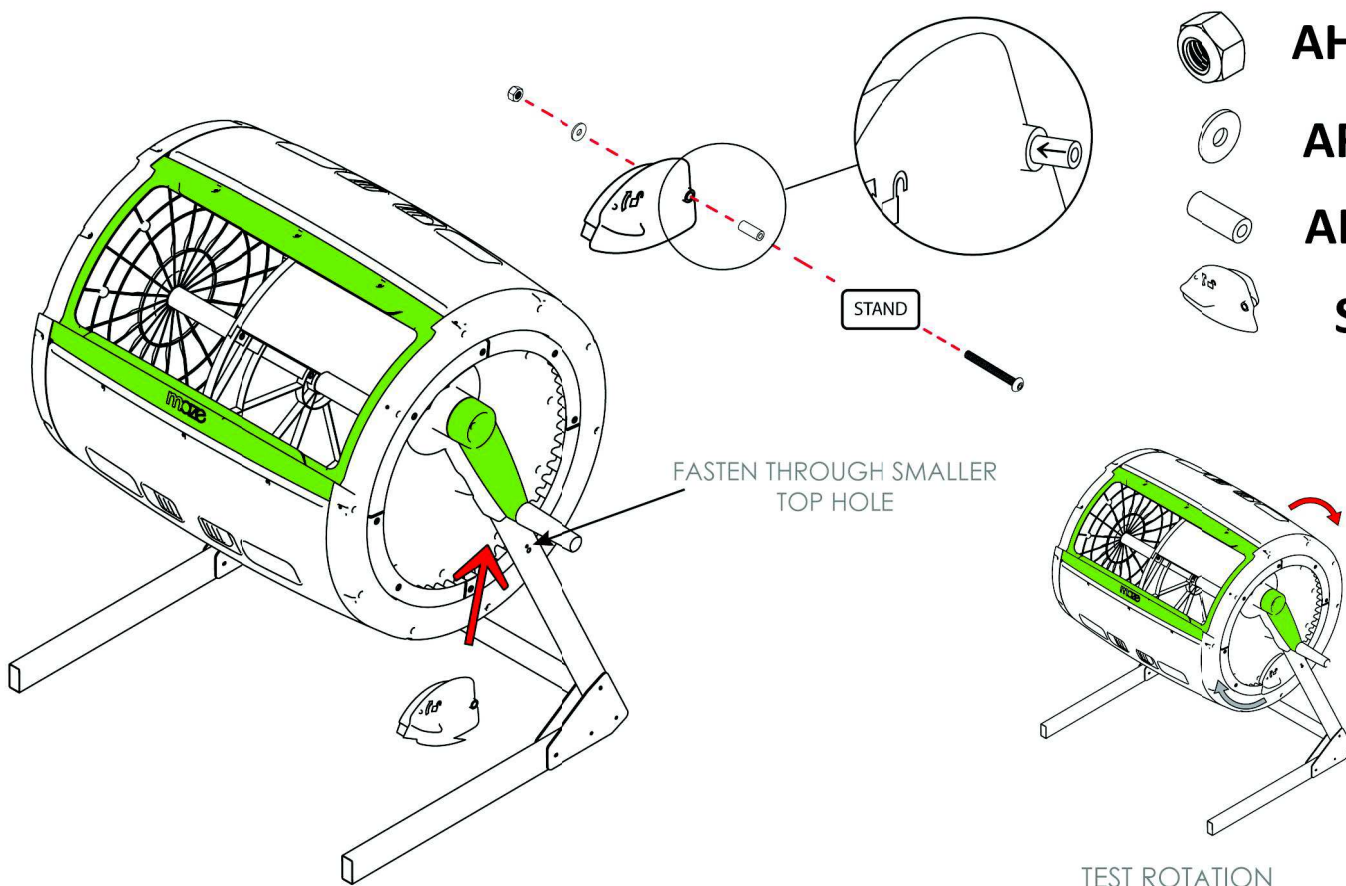
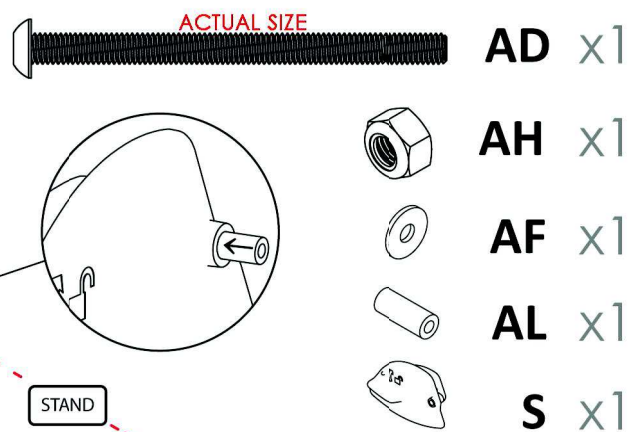

STEP 21

 **G** x1

 **H** x1

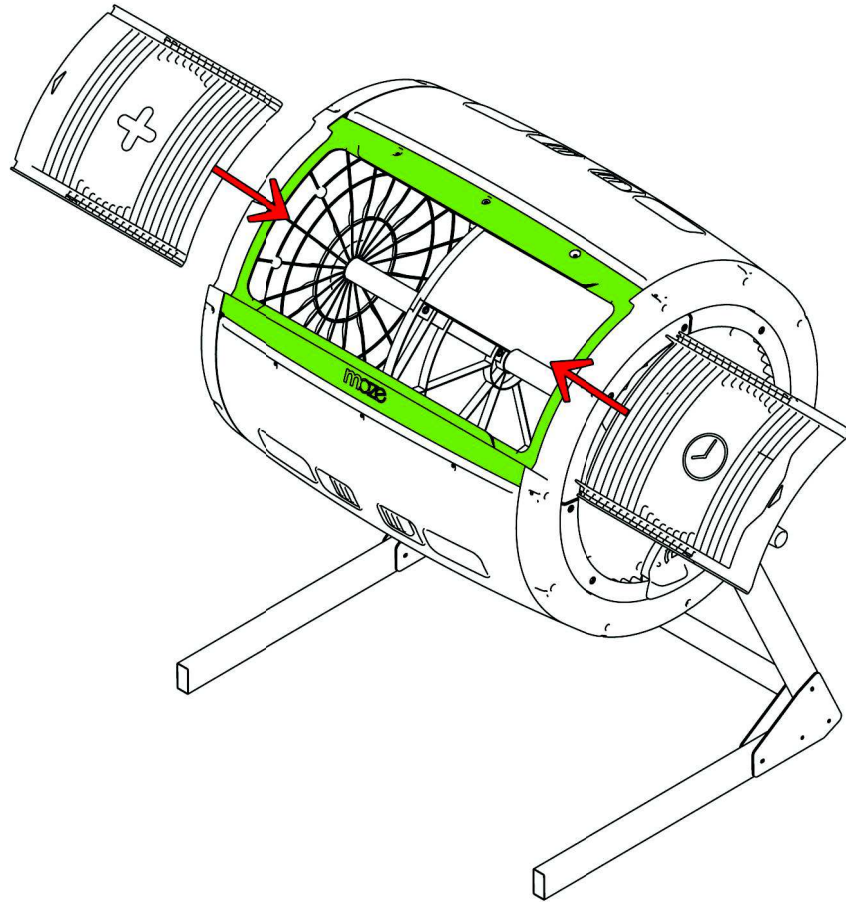

STEP 22

 **AK** x1

 **AJ** x1

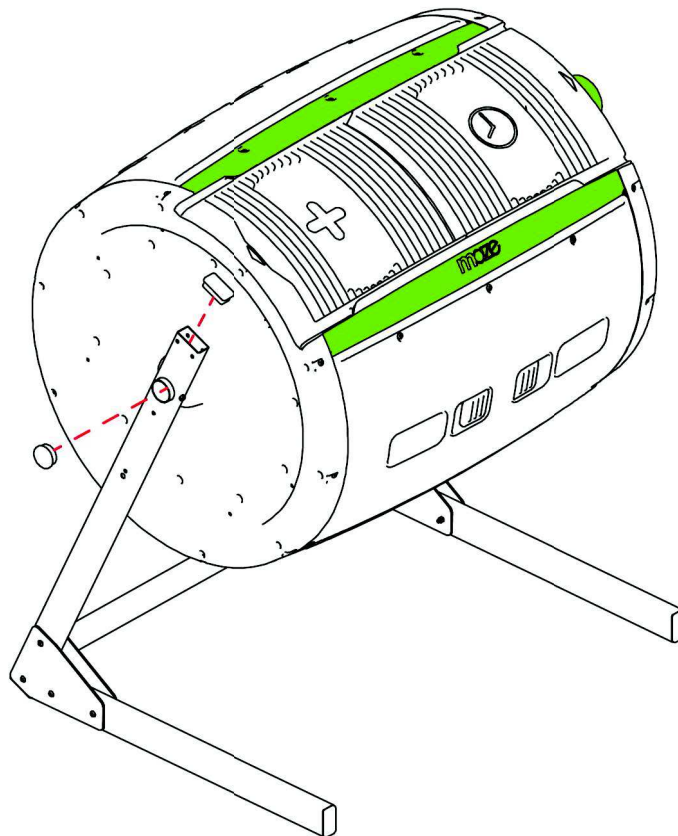

FEATURES:

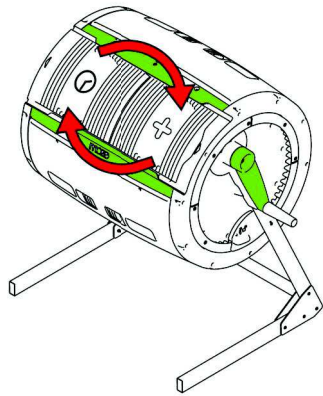

SLIDING DOORS ARE INTERCHANGABLE ON EITHER SIDE OF BARREL

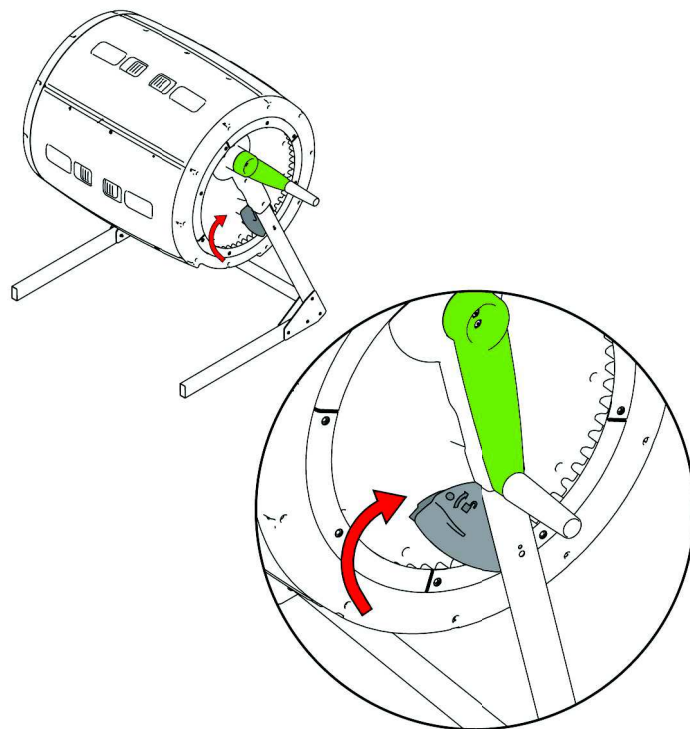

PULL AND ROTATE RATCHET UP, SO THAT BUMP ON RATCHET SNAPS IN PLACE BEHIND CRANK COVER

LOCKING THE RATCHET IN THIS POSITION WILL ALLOW THE BARREL TO ROTATE FREELY

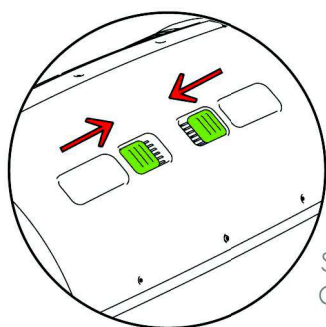

SLIDE OPEN OR CLOSE AIR VENTS

WARNINGS:

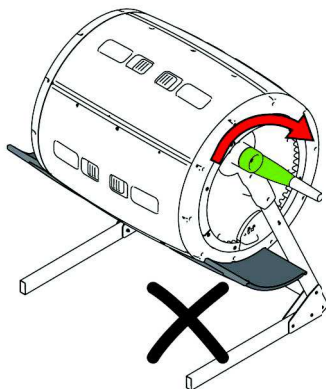

DO NOT ROTATE BARREL WITH DOORS OPEN

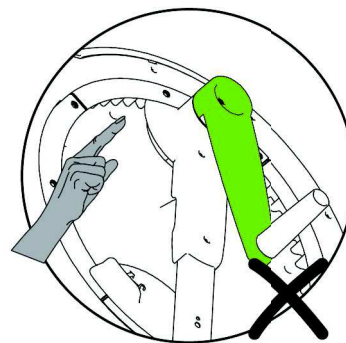

BEWARE OF CATCHING FINGERS IN GEARS

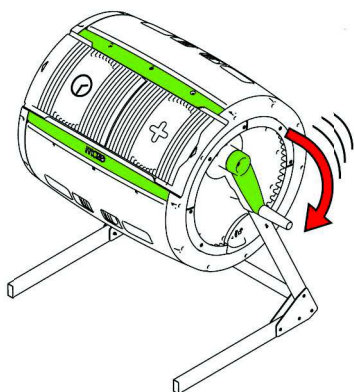

STAND CLEAR OF HANDLE AS IT MAY SPIN FAST

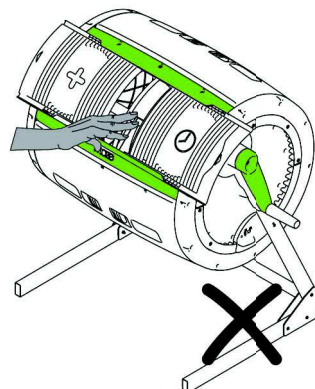

BEWARE OF CATCHING FINGERS IN DOOR

How to compost – Brief guide to get you started

1. Why compost?

Composting is a noble art with a very long history in sustainable food production. More and more, people are motivated by the desire for healthy soil, healthy food and a smaller environmental footprint. If all food waste was composted, food grown in our farms and gardens would be healthy, tasty and good to eat. *Read more at mazingredients.com.au/composting*

2. How to compost

Making compost is just like making a cake. We need the right ingredients in the correct proportions and mixed properly. We also need to get the moisture content and aeration right. But unlike making a cake, we don't have to be too precise about how we mix things.

In simple terms, we are managing a balance between stuff that is easy to break down, and stuff that takes a bit longer. This is most easily understood by calling the easy-to-break-down stuff the 'green', and the harder-to-break-down stuff, the 'brown'. A 50/50 mixture of green to brown is a great place to start for successful composting.

Simple steps

1. Collect kitchen scraps in a kitchen caddy or indoor composter. It will speed things up if you chop this waste where possible.
2. Add the kitchen scraps to composter with some 'brown' scraps at similar timeframes. Try to chop up or shred the brown waste as well if possible.

If using the divided option start by adding to one half only. Use the door with the '+' symbol to remind you which side is being filled.
3. Turn the composter at least 2-3 times a week. When adding waste always give it a few turns.
4. Keep adding until full (or too hard to turn) ensuring to keep the consistency right. Once the first side is full, start filling the other compartment. Make sure to swap the doors so now the '🕒' door is on the side that you just filled and the '+' is on the empty side.
5. You will know when the '🕒' side is ready when the contents look and smell like soil. Once it is ready, rotate the opening to the bottom, place a bucket or Compost Cart under and then slide the door open to let the compost fall out. You may need to help it come out by using a trowel to scrape it out
6. Once empty swap the doors around again and start filling the empty side and repeat

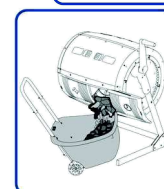
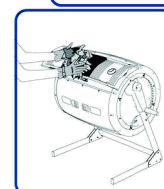
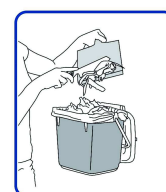

3. What to compost

Table 1 below gives you an idea of what is green and what is brown. Table two gives you some idea of what else you can / cannot put into a compost. For best results chop or shred greens and browns before adding, and make sure the mix is moist, not wet. Remember, we want to blend green and brown 50 / 50 by weight, not by volume.

Table 1. Green and Brown Compost Inputs

Green	Notes
Green leaves	Good to use
Grass clippings	Great addition when mixed well; can become smelly if not mixed
Green weeds	Avoid putting in seeds or runners
Fruit or vegetable scraps	Good to use
Cut flowers	Good to use but chop up into 100mm lengths before adding
Cooked food	No chunky meat, cheese or very oily wastes (e.g. fine meat or cheese like leftover spaghetti bolognese is ok)
Cow, horse, pig, chicken manures (not dog or cat)	Good to use. Dog and cat manures can harbour diseases so best not to use.
Lucerne hay	Good to use
Blood and bone or dynamic lifter	Use only if you have too much 'brown' materials. Sprinkle lightly and make sure everything is kept moist.

Brown	Notes
Brown leaves	Good.
Dead grass or weeds	Good.
Paper and cardboard	Good
Mulch, Sawdust, Hay or Straw	Good to use if you have an imbalance of 'green'.

Table 2. Do's and Don't's

Do not use:	Cooking oil, dog or cat manures, chunky meat or cheese, bones
OK to use:	Egg shells, wood ash, bread, milk or juice past its 'use by' date

Read more at mazingproducts.com.au/composting

4. How to use compost

This is where you get rewarded for your attention to your compost bin. Composting can take anywhere from 8 weeks to 24 weeks to mature and be ready to be applied to your garden. Compost that you buy from the hardware is usually quite fine because commercial composters screen the material before sale to remove the chunky bits.

You are encouraged to do the same as you will most likely find large particles such as twigs or mango or avocado stones still not broken down. It is a simple process to remove these by hand and put them back into the compost to continue breaking down.

Compost can be surface applied or dug into the soil. If you are applying compost to an established garden or under fruit trees, you really have no choice but to apply it to the surface as you can't easily dig it in. If you are applying compost to your vegetable garden, then you want to dig it in. *read more ... at mazingproducts.com.au/composting*

For more info, FAQs and troubleshooting visit mazingproducts.com.au/composting