

CONSUMER WARRANTY & SERVICE INFORMATION

Distributors **ONLY** warrant products with an active
Warranty Registration

ALWAYS ACTIVATE YOUR WARRANTY IMMEDIATELY ON
<https://nauticaseascooters.com/pages/warranty>

Distributors in the United States and Canada provide a Standard Limited Warranty for 6 months from the date of purchase for new products. If you're not located in the United States or Canada, please contact your Local Distributor for warranty arrangements in your territory. Please visit www.seascooter.net for Distributor / Service Center details. Distributors **ONLY** warrant NAUTICA Seascooter products purchased from an authorized dealer and with an original purchase receipt. All warranties are limited to a single original owner on the purchase of new and current product from an authorized reseller. Closeouts, Discontinued and Secondary sales of any kind including "like new" or out of box are not eligible for warranty consideration.

This warranty gives the consumer specific legal rights, and those rights may vary from place to place. Ask your Local Distributor for the warranty period in your region by calling their Service Center. Any part of the product supplied by the Distributor and found in the reasonable judgment of the Distributor to be defective in material or workmanship will be repaired or replaced then returned by the Distributor without charging for parts and repair costs. The product including any defective part must be sent to the Distributor within the warranty period. The customer will pay for the expense of delivering the product to the Distributor.

This warranty does not cover any product that has been subject to misuse negligence or accident, or that has been operated in any way contrary to the operating instructions as specified in the User Manual. Any flood, loss or damage, for any reason, that is caused by accidental release and sinking of the unit, or from flooding an o-ring sealed or water tight area will not be covered under warranty. This warranty does not apply to theft, loss, abuse or tampering, lack of maintenance, improper storage, exposure to excessive temperature, extended sunlight, material interactions, deteriorating chemicals or fumes, any damage to the product that is the result of improper maintenance or parts replacement performed by someone other than the official Distributor Service Center or to any product that has been altered or modified so as to change its intended use. This warranty does not extend to repairs made necessary by normal wear or by the use of parts or accessories which are either incompatible with the product or adversely affects its operation, performance or durability.

LICENSED PRODUCT

NAUTICA
MARINE200 MARINE250
MARINE280 MARINE300

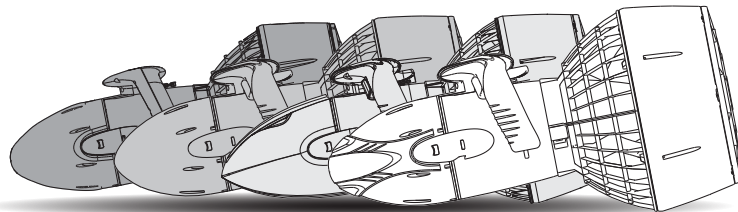

User Manual
English Version

BC



CAUTION

ELECTRICALLY OPERATED PRODUCT

Not for children under 16 years of age. As with all electrical products, precautions should be observed during handling to reduce the risk of electric shock.



SEE NEXT PAGE

FCC Statement

(For USA Regulation Only)

This device complies with Part 15 of the FCC Rules. Operation is subject to the following two conditions:

- (1) This device may not cause harmful interference, and
- (2) This device must accept any interference received, including interference that may cause undesired operation.

Warning: Changes or modifications to this unit not expressly approved by the party responsible for compliance could void the user's authority to operate the equipment.

NOTE: This equipment has been tested and found to comply with the limits for a Class B digital device, pursuant to Part 15 of the FCC Rules. These limits are designed to provide reasonable protection against harmful interference in a residential installation. This equipment generates, uses and can radiate radio frequency energy, if not installed and used in accordance with the instructions, may cause harmful interference to radio communications.

However, there is no guarantee that interference will not occur in a particular installation. If this equipment does cause harmful interference to radio or television reception, which can be determined by turning the equipment off and on, the user is encouraged to try to correct the interference by one or more of the following measures:

- Reorient or relocate the receiving antenna.
- Increase the separation between the equipment and receiver.
- Connect the equipment into an outlet on a circuit different from that to which the receiver is connected.
- Consult the dealer or an experienced radio/TV technician for help.

Contents

Introduction	1
Parts Diagram	2
Warnings	4
Getting Started	7
Battery Use	12
Charging the Battery	16
Camera Assembly	22
Care & Maintenance	23
Trouble Shooting	24
Technical Specifications	29



Discarded electrical appliances are recyclable and should not be discarded in the domestic waste! Please actively support us in conserving resources and protecting the environment by returning this appliance to the collection centers (if available).



User manual is also available in PDF format, contact your local distributor to a copy if needed.

Introduction

Thank you for having chosen the SEASCOOTER™ MARINE 200 / MARINE 250 / MARINE 280 / MARINE 300 - with the SEASCOOTER™ swimming, snorkeling and diving is effortless and fun. (Only use the Seascooter for scuba diving if you are a qualified diver)

Use appropriate equipment such as wetsuit, buoyancy control device, fins, mask & snorkel, surface signaling device, regulator(s) approved life jacket etc. when operating the Seascooter.

Only operate the Seascooter in water.

- SEASCOOTER™ MARINE 200 -

- Speed up to 2.0 mph / 3.2 km/h
- Runs up to 1 hour with normal use
- Rated to 65 ft / 20 m
- Weighs only 13.9 lb / 6.3 kg including battery

- SEASCOOTER™ MARINE 250 -

- Speed up to 2.5 mph / 4 km/h
- Runs up to 2 hours with normal use
- Rated to 100 ft / 30 m
- Weighs only 17.8 lb / 8.1 kg including battery

- SEASCOOTER™ MARINE 280 -

- Speed up to 2.8 mph / 4.5 km/h
- Runs up to 1.5 hours with normal use
- Rated to 100 ft / 30 m
- Weighs only 18 lb / 8.2 kg including battery

- SEASCOOTER™ MARINE 300 -

- Speed up to 3 mph / 4.8 km/h
- Runs up to 1.5 hours with normal use
- Rated to 100 ft / 30 m
- Weighs only 18 lb / 8.2 kg including battery

There are many features incorporated in this sophisticated design, please take time to study the manual to learn about them all to get the most out of your SEASCOOTER™.



The Seascooter is designed for use in seawater. It will have less buoyancy in fresh water, lake or pool and may sink in such waters.

Parts Diagram -SEASCOOTER MARINE 200-

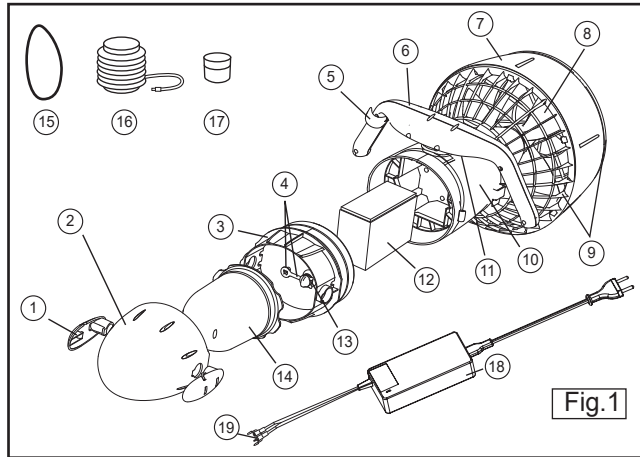

- | | |
|----------------------|------------------------------|
| 1 Latch | 11 Master Switch |
| 2 Nose Cone | 12 Battery |
| 3 Inner Nose Cone | 13 Vent Hole |
| 4 Vent Plug | 14 Buoyancy Control Chamber |
| 5 Trigger | 15 Silicone Ring |
| 6 Handle | 16 Pump |
| 7 Nozzle | 17 Silicone Grease (8 grams) |
| 8 Propeller | 18 Charger |
| 9 Protective Grilles | 19 Charger Jack |
| 10 Battery Housing | |

2

Parts Diagram -SEASCOOTER MARINE 250 / MARINE 280 / MARINE 300-

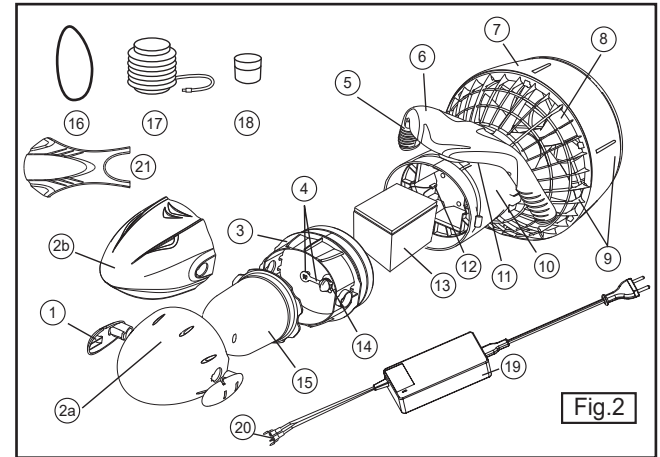

- | | |
|---|---|
| 1 Latch | 12 Battery Leads |
| 2a Nose Cone
(MARINE 250 & MARINE 280) | 13 Battery |
| 2b Nose Cone (MARINE 300) | 14 Vent Hole |
| 3 Inner Nose Cone | 15 Buoyancy Control Chamber |
| 4 Vent Plug | 16 Silicone Ring |
| 5 Trigger | 17 Pump |
| 6 Handle | 18 Silicone Grease (8 grams) |
| 7 Nozzle | 19 Charger |
| 8 Propeller | 20 Charger Jack |
| 9 Protective Grilles | 21 Nose Cone Protector
(For MARINE 280 only) |
| 10 Battery Housing | |
| 11 Master Switch | |

3



WARNING



- A child under 16 years old should never operate this product.
- The Seascooter is designed for 1 person use.



- This is not a life saving device. DO NOT use it as a buoyancy aid.



- Read the User Manual carefully before using the product.



- Always ensure sufficient charge remains in the battery to return to the shore surface before using the Seascooter.



- Do not use alcohol or mind-altering drugs prior to and during use of this product.



- ALWAYS inspect the swimming area to ensure it is free of hazards or obstacles such as boats or swimmers before using the Seascooter.



- Be aware of appropriate water levels, tidal changes, dangerous currents, weather change and strong offshore winds. ALWAYS scout unfamiliar water before venturing out.



- Crushing / Cutting Hazard



- Do not attach your body, clothing, other equipment to the seascooter in any way.



- ALWAYS wear a life vest (personal floatation device - PFD) approved by your local authorities for Snorkeling (U.S. Coast Guard Type III vest in the US or Canadian Coast Guard approved life vest in Canada or SAI Approval PFD in Australia or CE Approved PFD in Europe).



- Never place body parts, clothing or other objects in the vicinity of the propeller. Do not wear loose or flowing clothing or equipment that could be drawn into the propeller.



- Particular care should be exercised when using the Seascooter near anybody with long hair. Users with long hair should tie it up or wear a swimming cap when using the Seascooter.



- Be careful when you are transporting the Seascooter and setting it down to avoid crushing hazard on hands, foot or toes.



CAUTION

- Never remove the grilles except for maintenance.
- Always charge battery to its maximum before using the SEASCOOTER™. After charging is complete the battery will continue to emit gas. Wait at least 30 minutes after charging before removing the battery from the charger or placing the battery into the battery housing. Failure to do so could result in an explosion.
- The Seascooter™ is not a personal floatation device - always wear a Approved Personal Flotation Device / Approved Life-Preserver when using the Seascooter™ for snorkeling.
- ALWAYS keep the SEASCOOTER™ out of direct sunlight when not in use. HEAT KILLS BATTERIES AND IT MAY EXPLODE OR LEAK.
- When using the SEASCOOTER™ for SCUBA-DIVING, ascents and descents should be made in accordance with recognized diving practices.
- The SEASCOOTER™ should only be used for SCUBA-DIVING by qualified divers.
- Never open the Cover of the SEASCOOTER™ in the water.
- When not in use, always turn the Master Switch to the off position.
- Do not use the SEASCOOTER™ MARINE 200 below the recommended maximum depth of 20m/65ft.
- Do not use the SEASCOOTER™ MARINE 250 / MARINE 280 / MARINE 300 below the recommended maximum depth of 30m/100ft.
- ALWAYS remove the battery from the unit when not in use.
- DO NOT store the battery in the unit
- In different waters (seawater, lake, pool) and conditions such as currents, temperature and pressure can affect the buoyancy of the unit which may cause the unit to sink if accidentally released.
- DO NOT release or leave the Seascooter in the water. Always take the unit out of water when not in use.
- The Seascooter shall not be used in reverse direction.
- Adequate lighting shall be used when using the Seascooter in dark waters and during night diving.
- Do not use the unit if it is damaged in any way.
- When using the Seascooter for scuba diving, ascents and descents should be made in accordance with recognized diving practices.
- Due to safety considerations those who have not obtained a C-Card (attesting to completion of training) from an entity providing diving instruction must not under any circumstances use this product for diving.
- Keep the manual since it contains important information.



CRUSHING HAZARD:

The following action during assembly, disassembly, and transportation of the Seascooter may incur crushing hazards to your fingers or toes:

- Closing the nose cone latches
- Putting on the nose cone housing
- Placing the battery into the Seascooter
- Accidental dropping of the Seascooter or battery

When you buy the SEASCOOTER™ the battery is disconnected and needs to be charged. Follow the Battery Instruction on pages 12 to 15 and charging instructions on pages 16 to 19.

Using the SEASCOOTER™ for swimming and snorkeling.

When swimming or snorkeling the SEASCOOTER™ should be kept positively buoyant - this is done by simply making sure the Buoyancy Chamber is empty and fitted inside the Nose Cone.

To use the SEASCOOTER™ for swimming or snorkeling follow these instructions.

1. Charge the battery and install just before use.
2. Make sure that Vent Plug is closed.
3. Replace the Buoyancy Control Chamber.
4. Place the SEASCOOTER™ into the water so the Handle, Outer Nose Cone and Nozzle fill with water.

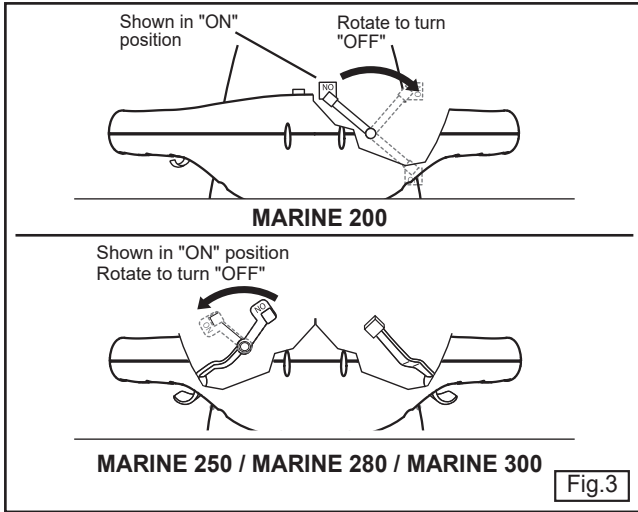

5. When ready to set off, turn the Master Switch to the On position shown in figure 3.
6. **For US version:** Pull and hold the Trigger(s) to start the Propeller.
For EU version (MARINE 250 / MARINE 280 / MARINE 300 Only):
Pull and hold both Triggers to start the Propeller.
(There is a short delay before the Propeller begins to rotate).
7. To stop the Propeller, simply release the Triggers.
8. Always turn the Master Switch off when out of the water.
9. Proper posture when using the SEASCOOTER™ is important to achieve the maximum speed - see figure 4 for the correct position of the SEASCOOTER™ when using it.

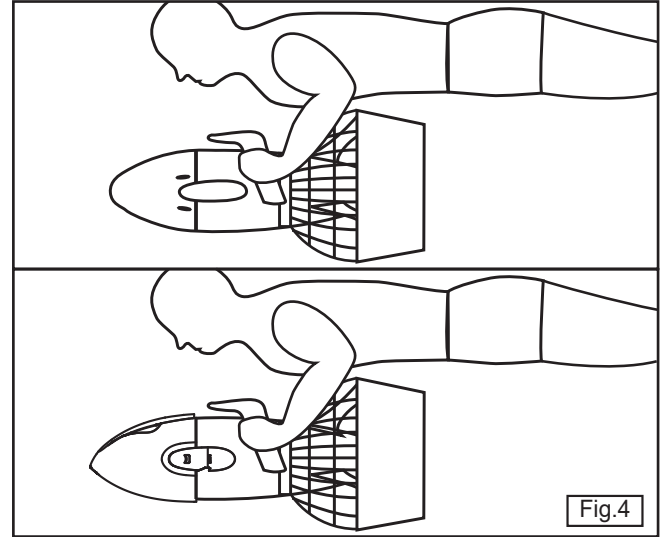

CAUTION

Do not dive deeper than you would normally when snorkeling, to ensure you can get back to the surface safely.

Important Notice: This machine is not to use to mix or to work with sand, concrete and material with similar physical characteristics. This machine is only to use for swimming and diving in water.

**Use of Variable Speed
(For US MARINE 300 ONLY)**

Your Seascooter MARINE 300 features two speeds - for normal speed, pull the right trigger only. For the higher speed, pull both triggers together.

Using the SEASCOOTER™ for diving - adjusting the buoyancy.

Your SEASCOOTER™ MARINE 200 can be used for diving up to 20m/65ft but will need to be adjusted for neutral buoyancy.

Your SEASCOOTER™ MARINE 250 / MARINE 280 / MARINE 300 can be used for diving up to 30 m / 100 ft but will need to be adjusted for neutral buoyancy.

The SEASCOOTER™ must never be adjusted for negative buoyancy to avoid it sinking if accidentally released.

To adjust for neutral buoyancy follow these instructions

1. Make sure the SEASCOOTER™ is in the Off position.

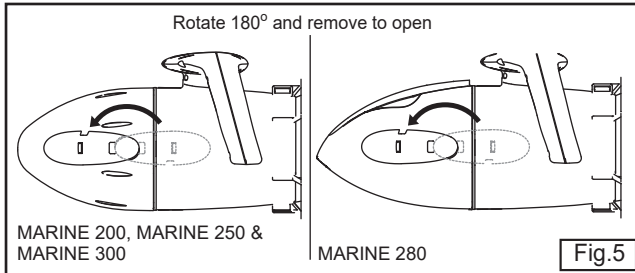

2. Remove the SEASCOOTER™ from the water, give a half turn to the Latches, remove them (see figure 5) and remove the Buoyancy Control Chamber.

3. Open the Buoyancy Chamber and add a small amount of rocks or a lead weight (see figure 6).

4. Cover the Buoyancy Chamber with the Nose Cone then secure the latches and place the SEASCOOTER™ in the water. If the SEASCOOTER™ is neutrally buoyant it will neither float nor sink.

5. If the SEASCOOTER™ sinks, remove the weight until it is neutrally buoyant.

If the SEASCOOTER™ is still positively buoyant repeat step 3, until it is neutrally buoyant.

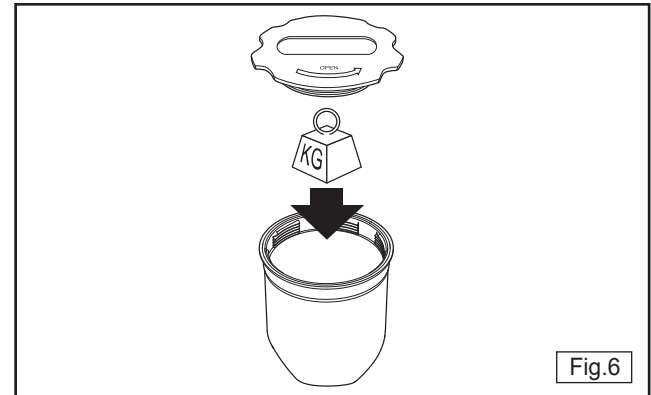

CAUTION

If the SEASCOOTER™ is later used for swimming or snorkeling be sure to remove the weight from the Buoyancy Chamber so the SEASCOOTER™ has positive buoyancy.



WARNING BATTERY SAFETY

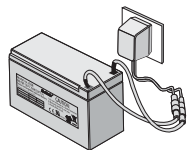

RE-CHARGE THE BATTERY
AT LEAST
**3 EVERY
MONTHS**

- Must remove and store the battery separately from the unit when not in use!
 - Must re-charge the battery after use **WITHIN 24 HOURS**.
- Must re-charge the battery at least **EVERY THREE MONTHS** when not in use.

User Manual must be read and understood before use.

Please read and follow the **Battery Safety Instruction**.

Incorrect battery maintenance may reduce the battery life and influence its function.



CAUTION BATTERY SAFETY

- **Our lead-acid battery is designed specifically for each Seascooter. For your own safety, NEVER REPLACE THE ORIGINAL SEASCOOTER BATTERY WITH AN AFTERMARKET BATTERY.**
- Only Seascooter with original battery will be warranted by our service center.
- Always contact official dealer/service center to service the Seascooter. Any changes made by consumer/unauthorized parties will void the warranty of the Seascooter.
- Visit our website to purchase replacement battery for Seascooter.
- Visit our website to find an original equipment battery distributor in your region.

www.seascooter.net



CAUTION

- Your SEASCOOTER™ is supplied with a battery that needs to be treated carefully as it will release potentially explosive gases during its normal cycle of use (off-gassing). Failure to do so can result in an explosion occurring. Please read the entire manual thoroughly and follow all instructions.
- Always remove the battery from your SEASCOOTER™ when it is not in use. Store separately in a well ventilated area where it is out of the reach of children and away from heat and ignition sources.
- Do not attach the battery in your SEASCOOTER™ until prior to using it.
- Before disconnecting/connecting any cables, open the nose cone and allow two minutes for any explosive gases to dissipate.
- Do not use/store/charge the battery in temperatures above 40°C (104°F) as excessive off-gassing may occur. Keep the battery and SEASCOOTER™ in the shade when not in use.
- Always ensure the unit is dried thoroughly before opening the Nose Cone.
- Only use the charger supplied with the SEASCOOTER™.



CAUTION

- The battery supplied with your SEASCOOTER™ releases a potentially explosive gas during charging. Charging should only take place in a well ventilated area, away from children and open flames or other ignition sources (cigarettes, sparks). Never charge the battery while still in the SEASCOOTER™.
- Charge the battery as soon as possible after use within 24 hours.
- Always charge the battery to the fullest before using the SEASCOOTER™.
- Always remove the battery from the battery housing before charging.
- Always connect charger jack to the battery first and then plug charger into the electrical socket/plug.
- After charging, disconnect from the electrical socket/plug first and then disconnect the battery from the charger.
- After charging is complete the battery will continue to emit gas. Wait at least 30 minutes after charging before removing the battery from the charger or placing the battery into the battery housing. Failure to do so could result in an explosion.
- Remove battery from charger once fully charged.



CAUTION

- Never charge the battery in sealed container.
- Never charge the battery near water.
- Never short circuit the battery or battery connectors.
- Always ensure the charger is dry before use.
- The charger gets quite warm in use - this is normal.
- If in doubt of the state of the battery, recharge it until the indicator on the battery charger indicates a full charge.
- If the battery is not to be used for an extended period, store it in a well ventilated area away from children, heat, and ignition sources. Recharge it every three months to maintain charge and avoid excess off-gassing. DO NOT store the battery inside the SEASCOOTER™.
- If the battery appears damaged or will not fully charge, the battery must be replaced. If battery life is noticeably reduced, the battery should be replaced.
- The battery supplied with your SEASCOOTER™ should last about 200 cycles or two years before it should be replaced. Please contact your local customer service center/distributors. Using a battery in excess of these recommendations can result in excessive off-gassing of explosive gases.
- Always keep the battery terminals clean.
- To prevent short-circuiting or fire, keep the battery away from other metal objects when carrying or storing.
- To prevent short-circuiting or fire, always ensure the charging area is safety during charging.

Charging the Battery



WARNING

- The instructions concerning persons (including children) with reduced physical, sensory or mental capabilities, or lack of experience and knowledge and children playing with the appliance are not applicable.
- The connector must be removed before the appliance is cleaned and that the appliance inlet must be dried before the appliance is used again.
- Detachable power supply part shall be provided with the part of class III construction of the appliance.
- The transformers or battery chargers used with the product are to be regularly examined for damage to the cord, plug, enclosure and other parts, and in the event of such damage, they must not be used until the damage has been repaired.

Replace the battery immediately if it is damaged.

For battery charging follow these instructions.

1. Always ensure that the Master Switch is Off - see figure 3.
2. Always ensure that the SEASCOOTER™ is out of the water, dry and placed in a dry area.
3. Give a half turn to the Latches and remove them from the Nose Cone as shown in figure 5.
4. Remove the Outer Nose Cone and Buoyancy Control Chamber.
5. Open the Vent by unscrewing the Vent Plug.
6. Remove the Inner Nose Cone. To do this, first feed the Silicone Ring (provided with this manual) through the latch holes in the Inner Nose Cone and pull over the hooks on the Battery Housing (see figure 7). Then screw the Pump Nozzle onto the Vent Hole and pump air into the Battery Chamber until the Inner Nose Cone pops off and then remove the Silicone Ring.
7. Allow two minutes for any gases to dissipate.
8. Disconnect the battery cable from the housing cable (if not already disconnected - the cable will be disconnected when you buy your SEASCOOTER™) by pressing the locking feature, as shown in figure 8.
9. Remove the battery and place on a level surface.
10. Connect the battery cable to the charger cable.
11. Plug charger into mains, and turn on the supply.

Important Notice: Keep the Silicone Ring permanently (Refer to Page 2 and 3, Parts Diagram). Removing the inner nose cone without the Silicone Ring is dangerous.

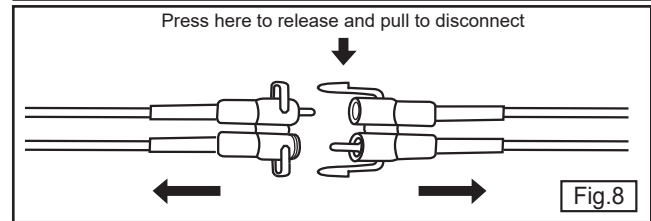
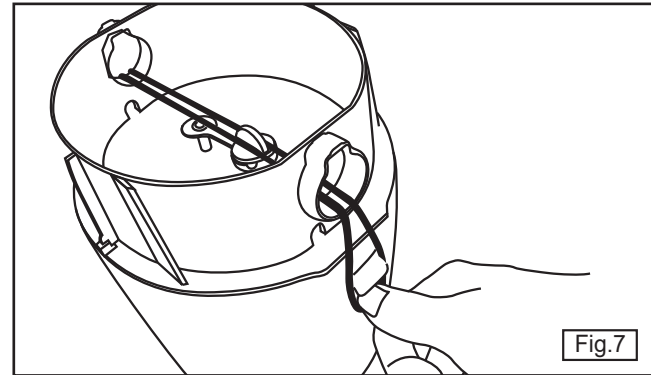

12. **SEASCOOTER MARINE 200** - Charging will take 3 - 4 hours for a fully discharged battery.

SEASCOOTER MARINE 250 / MARINE 280 / MARINE 300 - Charging will take 5 - 7 hours for a fully discharged battery.

When the battery is charging the red LED is lit, when the battery is charged the green LED is lit.

13. Disconnect the charger from the electrical plug/socket.
14. Allow battery to stand for 30 minutes before using it.

15. Unplug the battery cable from the Charger cable.
16. When ready for use, install the battery and reconnect to the housing cable.

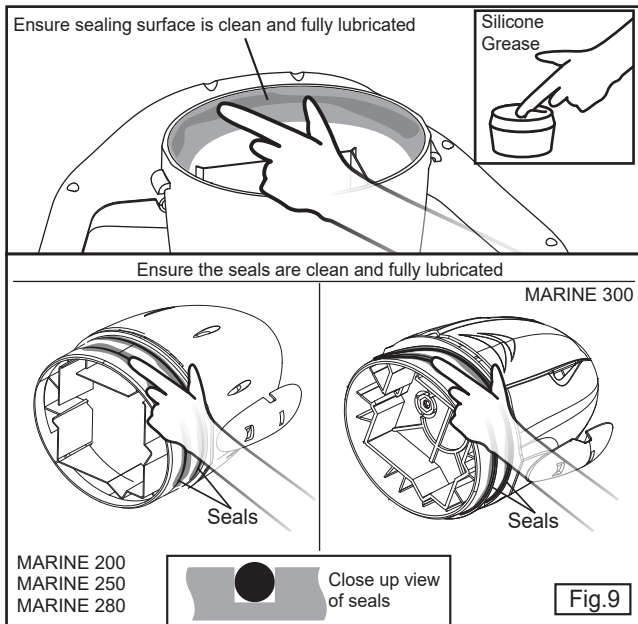

17. Make sure the seals and sealing surfaces are clean and fully lubricated with the supplied grease EVERYTIME (you can also buy this at your local hardware store) before replacing the Inner Nose Cone. See fig. 9.
18. Replace the Inner Nose Cone making sure the key is aligned correctly. See fig. 10.
19. Ensure the Vent O Ring is fitted correctly and fully lubricated with the supplied grease EVERYTIME (you can also buy this at your local hardware store). See fig. 11.
20. Screw in the Vent Plug to seal the vent.

21. Replace the Buoyancy Control Chamber.
22. Replace the Outer Nose Cone making sure the key is aligned correctly and insert the Latches and lock the Nose Cone by giving them a half turn. See fig.12.

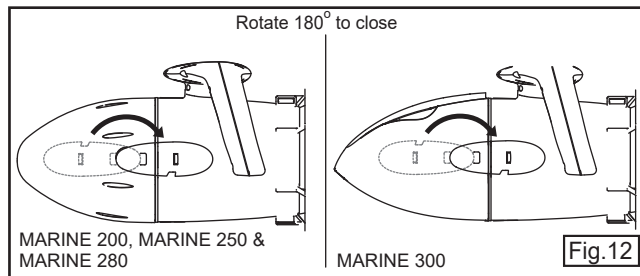
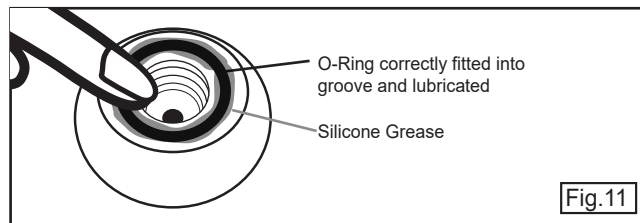
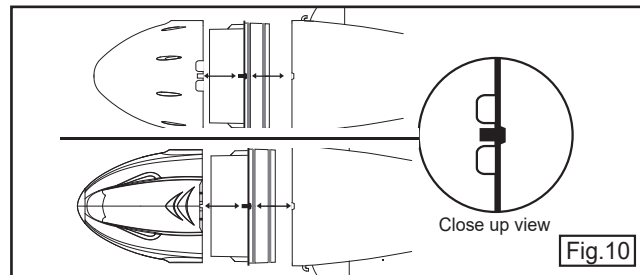

To replace a flat battery with a fully charged battery.

1. Follow the steps 1 to 7 on page 16, to open the SEASCOOTER™.
2. Unplug the battery at the socket by pressing the locking feature shown in figure 8.
3. Remove the flat battery.
4. Install and connect the charged battery in the correct position - the leads of the battery must be oriented, see figure 13.

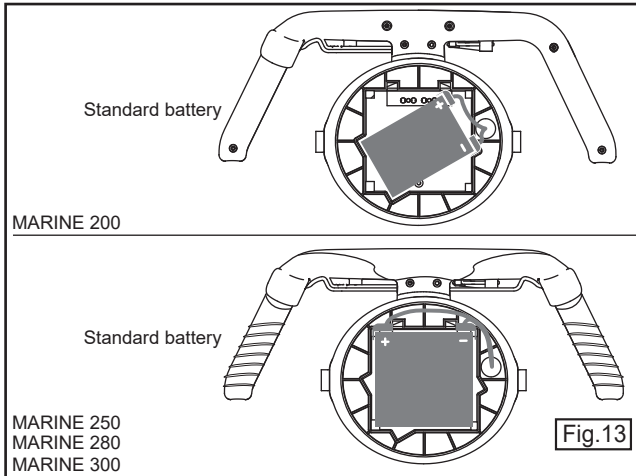

5. Follow steps 17 to 22 on page 18 and 19, to close the SEASCOOTER™.

**-SEASCOOTER MARINE 200-
Using the Optional Extended Life Battery.**

An optional extended life battery is available through your local customer service center/distributor. This battery fits into the Battery Housing in a slightly different position to the normal battery, the leads of the battery must be oriented, see figure 14.

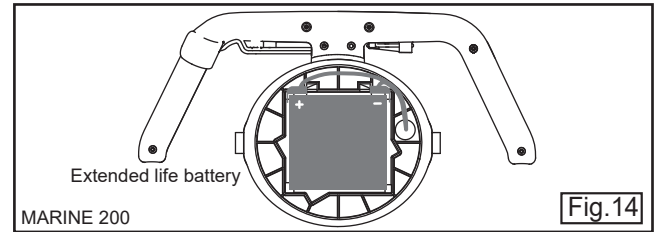

The extended battery can be charged in the same way as a standard battery.



CAUTION

Because this battery is heavier than a standard battery the Buoyancy Chamber must be added and empty to ensure the SEASCOOTER™ floats.

Buying batteries

Additional standard or extended batteries can be purchased separately. Contact your local customer service center/distributor to purchase them.

ATTACHING YOUR CAMERA TO SEASCOOTER MOUNTS (Can be used with GoPro® HERO [3, 3+, 4, 5, 6 or 7] cameras, or other camera with using the same mount system)

To attach your camera to Seascooter, you will need a thumb screw or hardware depending on the mount you are using.

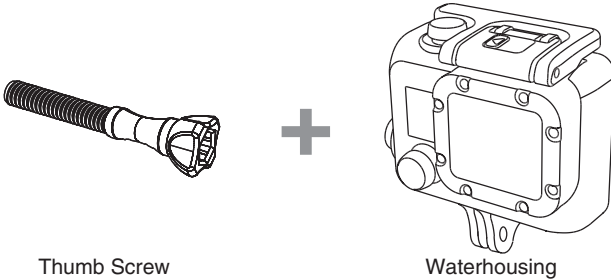

Thumb Screw

Waterhousing

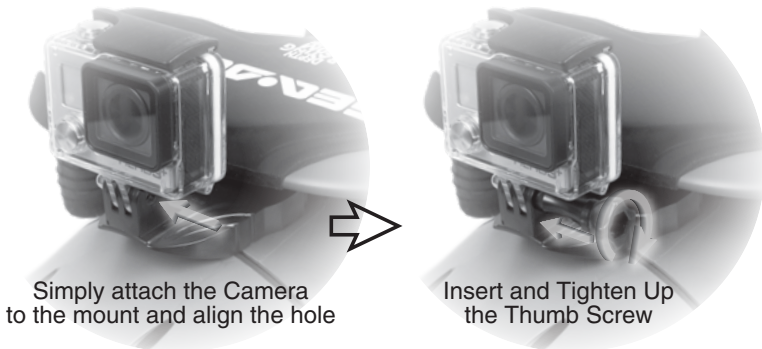

Simply attach the Camera
to the mount and align the hole

Insert and Tighten Up
the Thumb Screw

*Camera and Screw are not included

Battery Care

- Please read and understand important Battery Use safety information on pages 12 to 15.
- The battery supplied with your SEASCOOTER™ should last about 200 cycles or two years before it should be replaced. Please contact your local customer service centre/distributor. Using a battery in excess of these recommendations can result in excessive **off-gassing** of hazardous **gases**.
- ALWAYS remove the battery from the SEASCOOTER™ immediately after use.
- **DO NOT STORE BATTERY IN SEASCOOTER™**

Care after using the SEASCOOTER™

- DO NOT leave the Seascooter in the water. Always take the unit out of water when not in use.
- Always rinse the SEASCOOTER™ in fresh water and allow it to dry before storage immediately after use.
- To clean the SEASCOOTER™ do not use detergents, only use a damp cloth to wipe the unit clean.
- The Battery Housing interior should be kept dry at all times.
- If the Battery Housing interior ever gets wet, see page 28, Accidental Flooding for procedure.
- When storing the SEASCOOTER™ for extended periods of time, open the Vent Plug in the Inner Nose Cone.
- ALWAYS store your SEASCOOTER™ vertically when not in use to prevent deformation of the Propeller Nozzle.

Trouble Shooting

Unit does not function

If the motor does not start when both triggers are pressed, make sure

1. The battery is properly connected.
2. The battery is fully charged.
(see page 16, charging the battery)
3. The master switch is in the "On" position.
(see fig 3, page 8)
4. There is no water in the battery compartment.
(see page 28, accidental flooding)

Blocked Propeller

If the Propeller becomes blocked first try and remove the obstruction by removing the front grille. If this is not possible the back grille and Propeller can be removed.

Under normal use the grilles must not be removed.

Removing the front grille to remove an obstruction.

1. Remove the SEASCOOTER™ from the water.
2. Make sure the master switch is in the Off position.
3. Insert a screw driver as shown in figure 15 (page 25) to remove the two grille pins.
4. Unclip grille as shown in figure 16 (page 25) .
5. Remove obstruction.
6. Reassemble grille and insert clips.

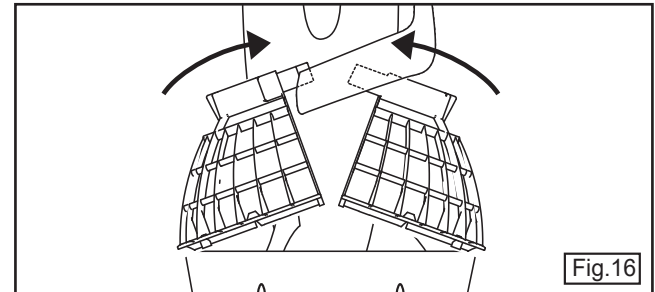
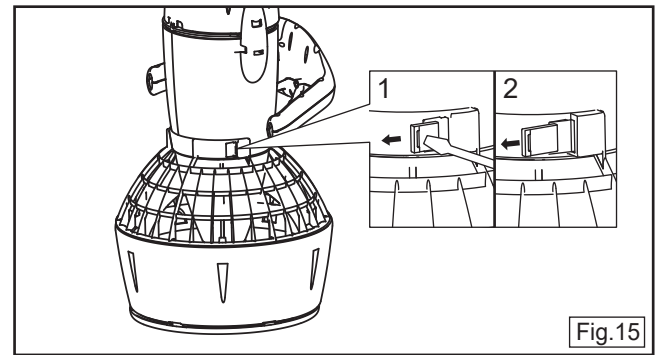

Removing rear grille and Propeller to remove obstruction



WARNING

Crushing / Cutting Hazard

Before opening the grille for maintenance purpose, make sure the master switch is in off position, and the battery is disconnected.

1. Remove the SEASCOOTER™ from the water.
2. Make sure the master switch is off.
3. Remove the battery - see page 16, step 1-9.

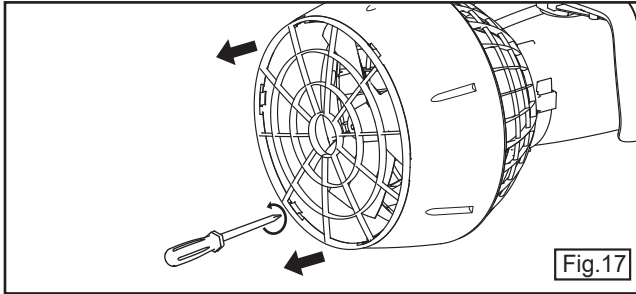

4. Unscrew the six rear grille screws as shown in figure 17.
5. While holding the Propeller, use an M6 socket to remove the nut from the Propeller shaft (See figure 18).

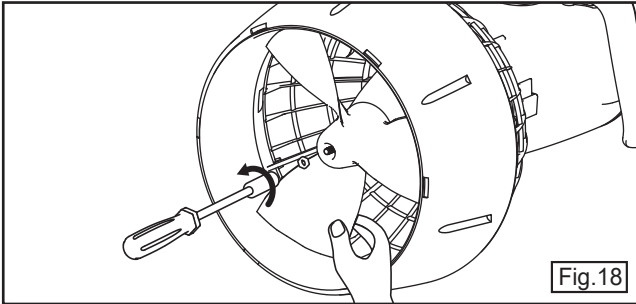

6. Slide the Propeller off the shaft, taking care not to loose the drive pin or washers.
7. Remove the blockage from the Propeller.
8. Replace the drive pin (if removed), see figure 19, and Propeller. Turn the Propeller slowly until you locate the pin and push the Propeller fully on.

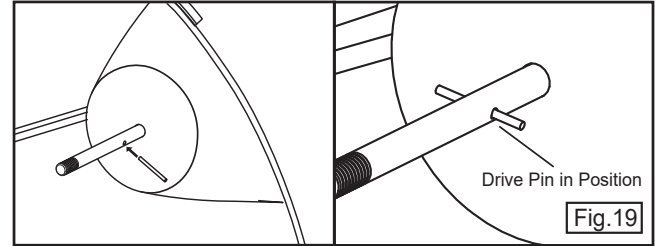

9. Replace the washer(s) and nut and tighten with the socket while holding the Propeller making sure it is securely fastened (See figure 20).
10. Replace the grille.
11. Replace the battery.

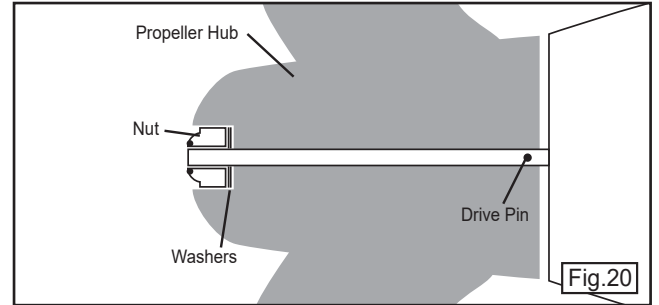

Sand or Grit on Seals

Ensure that sand/grit does not get on the seals as correct maintenance and care is essential. To remove sand or grit from the seals, rinse the seals in fresh water and apply fresh lubricant. If there is sand inside the Battery Housing, gently brush the sand from the unit taking care not to scratch the sealing surfaces.

SEASCOOTER™ cuts out

To protect the electronic circuit of your SEASCOOTER™ from damage a safety mechanism has been built in that cuts the power if a wall or rock or other immovable object is hit. If this occurs simply wait for a short period to allow the SEASCOOTER™ to reset itself and resume use.

Accidental Flooding

It is important that the seal is kept sand and grit free to ensure they keep water out and to close the vent plug after accessing the battery chamber. However, should the seals not be clean or the vent plug left open and water enters the battery chamber, your Seascooter will not be damaged as it is designed for protection against accidental flooding.

If water enters the battery chamber:

1. Remove the SEASCOOTER™ from the water if it is safe to do so. Always observe safe diving practice.
2. Remove nose cone and tip out excess water.
3. Wait two minutes for any gases to dissipate, then remove the battery.
4. If salt water has entered, rinse battery and battery housing with fresh water.
5. Dry housing and battery thoroughly.

-MARINE 200-

Unit Dimensions	24 inches x 15.2 inches x 12.3 inches (612 x 385 x 312 mm)
Unit Weight	13.9 lb (6.3 kg) (with rechargeable battery)
Battery Type	1 x 12V / 7.5 Ah rechargeable battery
Battery Life / Fully Charged	*Runs up to 1 hour with normal use ^Continuous use up to 40 minutes
Depth rating	20 m / 65 ft
Speed	Up to 2.0 mph (3.2 km/h)

-MARINE 250-

Unit Dimensions	24 inches x 15.2 inches x 12.3 inches (612 x 385 x 312 mm)
Unit Weight	17.8 lb (8.1 kg) (with rechargeable battery)
Battery Type	1 x 12V / 12 Ah rechargeable battery
Battery Life / Fully Charged	*Runs up to 2 hours with normal use ^Continuous use up to 45 minutes
Depth rating	30 m / 100 ft
Speed	Up to 2.5 mph (4 km/h)

-MARINE 280-

Unit Dimensions	24 inches x 15.2 inches x 12.3 inches (612 x 385 x 312 mm)
Unit Weight	18 lb (8.2 kg) (with rechargeable battery)
Battery Type	1 x 12V / 12 Ah rechargeable battery
Battery Life / Fully Charged	*Runs up to 1.5 hours with normal use ^Continuous use up to 30 minutes
Depth rating	30 m / 100 ft
Speed	Up to 2.8 mph (4.5 km/h)

-MARINE 300-

Unit Dimensions	25.1 inches x 15 inches x 12.6 inches (631 x 385 x 322 mm)
Unit Weight	18 lb (8.2 kg) (with rechargeable battery)
Battery Type	1 x 12V / 12 Ah rechargeable battery
Battery Life / Fully Charged	*Runs up to 1.5 hours with normal use △Continuous use up to 30 minutes (high Speed)
Depth rating	30 m / 100 ft
Speed	Up to 3.0 mph (4.8 km/h)

*Normal Use

The definition of normal use is based on the average general time of use the user activates the Seascooter in the water.

△Continuous Use

The definition of continuous use is based on a fully charged battery whereby the Seascooter is used continuously in the water without stopping.

**For more information on
Seascooter™ Products
(Warranty, Customer Care / Maintenance,
Parts & Battery Purchase)**

PLEASE VISIT
www.Nauticaseascooters.com

All corresponding specification appear in this manual are correct at the time of printing.
For the latest updates and further information on the complete range of the Seascooter™,
PLEASE VISIT www.Nauticaseascooters.com

This Product is not manufactured by Nautica. For consumer purposes,
please contact Sport Dimension Inc. at 1-800-678-7873.

(US & CANADA MARKET ONLY)

Please visit our website at www.Nauticaseascooters.com to find out your local distributor.

Products covered by the following patents:

USA, Canada, EU, Australia, Japan, Hong Kong, China & Turkey
US D471,506S / US D518,768S / D527,702S / US D506,176S / US D507,776S
D512,678S / D519,911S / 6848385 B2 / US 7000559 B2 / US 7093554 B1 / 11/102,302
0500577.8 / 0500578.0 / 0500579.2 / HK1072691 / ZL200530005661.5
ZL200430079550.4 / ZL200430057359.X / ZL200530005662.X / ZL200530005663.4
ZL200320103738.8 / ZL200520008894.5 / 1194933 / 1254107 / 1225250
000330311-0001 / 000183900-0001 / 000183900-0002 / 000330279-0001
000330295-0001 / 03020902.7 / 302949 / 302564 / 302563 / 302950
302948 / 2005100230 / 200503474 / 29/268,724 / 11/595,675 / 000816376-0001

US & CANADA MARKET ONLY

Toll Free (US) : 1-800-678-7873

info@nauticaseascooters.com

www.Nauticaseascooters.com

Nautica™ and ™ are trademarks of Nautica Apparel, Inc.

©Nautica Apparel, Inc. nautica.com

In addition, this warranty does not cover items that experience normal wear and tear.

ALL IMPLIED WARRANTIES ARE LIMITED IN THE DURATION TO THE WARRANTY PERIOD. AND SUCH IMPLIED WARRANTIES INCLUDING MERCHANTABILITY, FITNESS FOR A PARTICULAR PURPOSE, OR OTHERWISE, ARE DISCLAIMED IN THEIR ENTIRETY AFTER THE EXPIRATION OF THE APPROPRIATE WARRANTY PERIOD. THE DISTRIBUTOR'S OBLIGATION UNDER THE WARRANTY IS STRICTLY AND EXCLUSIVELY LIMITED TO THE REPAIR OR REPLACEMENT OF DEFECTIVE PARTS AND RETURN OF THE PRODUCT TO THE CUSTOMER. THE DISTRIBUTOR DOES NOT ASSUME OR AUTHORIZE ANYONE TO ASSUME FOR THEM ANY OTHER OBLIGATION.

THE DISTRIBUTOR ASSUMES NO RESPONSIBILITY FOR INCIDENTAL, CONSEQUENTIAL OR OTHER DAMAGES INCLUDING, BUT NOT LIMITED TO EXPENSE OF RETURNING THE PRODUCT TO THE DISTRIBUTOR, LOSS OF USE OF PRODUCT AND LOSS OF TIME OR INCONVENIENCE.

THIS PRODUCT IS DESIGNED AND INTENDED FOR PERSONAL RECREATIONAL USE ONLY!

THIS PRODUCT IS NOT WARRANTED FOR COMMERCIAL OR RENTAL USE!

REPAIR WORK OR DELIVERY OF A REPLACEMENT DOES NOT EXTEND OR RENEW THE WARRANTY PERIOD.

WARRANTY SHALL AUTOMATICALLY BE VOID IF DAMAGE IS RESULT OF NON-ORIGINAL PARTS.

LIMITED WARRANTY for Seascooters with camera mount:

- ALWAYS inspect to ensure the product works properly every time before use. Warranty of this product does not cover any damages due to misuse.
- Failure to follow the user(s) instructions on packaging and/or user(s) manual may result in damages or loss of your cameras including but not limited to any user's personal items, all of which are not covered under warranty of this product.
- Use at your own risk. Manufacturer(s) and/or suppliers/agents are not responsible for any damages/repairs, loss to cameras/electronic items including but not limited to any user's personal items directly and/or indirectly resulted in the use of this product. Damage(s) resulting from any use, misuse, accident, and normal wear and tear are understandably not covered under this product warranty nor be responsible by manufacturer(s) and/or suppliers/agents.

EXCLUSIONS

BATTERY. This warranty does not include the battery.

Never replace the original SEASCOOTER BATTERY with an AFTERMARKET BATTERY. Seascooter with aftermarket battery will not be covered by this warranty.

CUSTOMER ENQUIRIES

If your unit is not operating, please refer to your User Manual before contacting our Customer Service Center. For any damage or repair work required, please do not return your product to the store where it was purchased.

RETURN / REPAIR POLICY

Customers must contact their Local Distributor Service Center to ask for an official Claim Form. The Claim Form must be returned with the customer's contact details and a photo of the Seascooter, defective parts, the serial number and the Original Purchase Receipt. The Distributor Customer Service Center will review the case and issue a Return / Repair Authorization Number before sending the product to the Distributor Service Center. Returned products must be shipped with original packaging including the polystyrene packing material and all defective parts. Please contact your Local Distributor Service Center for assistance in handling your case.

Please visit our website www.Nauticaseascooters.com for a listing of most update distributor contacts and service center contacts.

RETURN / REPAIR PROCEDURE

1. Call the Customer Service Center for your Return / Repair Authorization Number.
2. Make a copy of your Proof of Purchase (receipt).
3. Pack the defective unit in its original packaging including the polystyrene foam and include the unit and all defective parts.
4. Attach the copy of your Proof of Purchase (receipt) to the outside of the box (clearly visible), together with the Return / Repair Authorization Number.
5. Ship the package to the Service Center on your cost.

PLEASE NOTE: Deliveries that do not have the Proof of Purchase (receipt) and Return / Repair Authorization Number attached clearly to the outside of the box, will not be accepted by the Service Center.

For any questions or queries you may have regarding your SEASCOOTER™, please follow the below steps for easy and fast resolution:

- STEP 1-

Please read your User Manual. For a copy of the User Manuals, please visit www.Nauticaseascooters.com

- STEP 2-

Go to www.Nauticaseascooters.com and see our FAQ section to find instant answers.

- STEP 3-

Contact one of our Customer Service representatives at the Customer Service Center in your region.