

## CONSUMER WARRANTY & SERVICE INFORMATION

Distributors **ONLY** warrant products with an active  
Warranty Registration

**ALWAYS ACTIVATE YOUR WARRANTY IMMEDIATELY ON**  
<https://nauticaseascooters.com/pages/warranty>

Distributors in the United States and Canada provide a Standard Limited Warranty for 6 months from the date of purchase for new products. If you're not located in the United States or Canada, please contact your Local Distributor for warranty arrangements in your territory. Please visit [www.seascooter.net](http://www.seascooter.net) for Distributor / Service Center details. Distributors **ONLY** warrant NAUTICA Seascooter products purchased from an authorized dealer and with an original purchase receipt. All warranties are limited to a single original owner on the purchase of new and current product from an authorized reseller. Closeouts, Discontinued and Secondary sales of any kind including "like new" or out of box are not eligible for warranty consideration.

This warranty gives the consumer specific legal rights, and those rights may vary from place to place. Ask your Local Distributor for the warranty period in your region by calling their Service Center. Any part of the product supplied by the Distributor and found in the reasonable judgment of the Distributor to be defective in material or workmanship will be repaired or replaced then returned by the Distributor without charging for parts and repair costs. The product including any defective part must be sent to the Distributor within the warranty period. The customer will pay for the expense of delivering the product to the Distributor.

This warranty does not cover any product that has been subject to misuse negligence or accident, or that has been operated in any way contrary to the operating instructions as specified in the User Manual. Any flood, loss or damage, for any reason, that is caused by accidental release and sinking of the unit, or from flooding an o-ring sealed or water tight area will not be covered under warranty. This warranty does not apply to theft, loss, abuse or tampering, lack of maintenance, improper storage, exposure to excessive temperature, extended sunlight, material interactions, deteriorating chemicals or fumes, any damage to the product that is the result of improper maintenance or parts replacement performed by someone other than the official Distributor Service Center or to any product that has been altered or modified so as to change its intended use. This warranty does not extend to repairs made necessary by normal wear or by the use of parts or accessories which are either incompatible with the product or adversely affects its operation, performance or durability.

# LICENSED PRODUCT NAUTICA

## J-CLASS

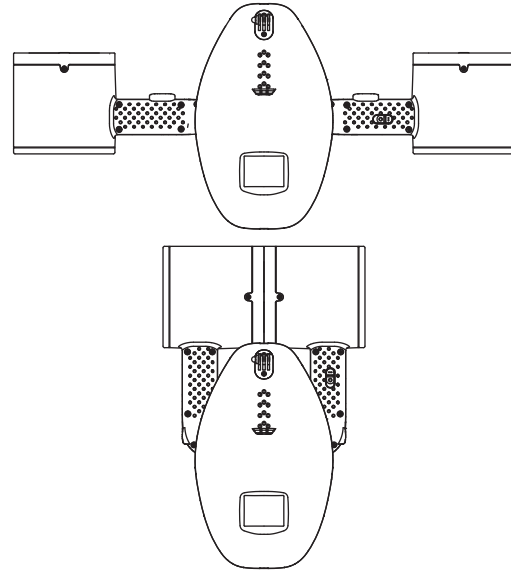

**User Manual**  
English Version

BC



## CAUTION

ELECTRICALLY OPERATED PRODUCT

Not for children under 16 years of age. As with all electrical products, precautions should be observed during handling to reduce the risk of electric shock.

SEE NEXT PAGE

## FCC Statement

### *(For USA Regulation Only)*

This device complies with Part 15 of the FCC Rules. Operation is subject to the following two conditions:

- (1) This device may not cause harmful interference, and
- (2) This device must accept any interference received, including interference that may cause undesired operation.

Warning: Changes or modifications to this unit not expressly approved by the party responsible for compliance could void the user's authority to operate the equipment.

NOTE: This equipment has been tested and found to comply with the limits for a Class B digital device, pursuant to Part 15 of the FCC Rules. These limits are designed to provide reasonable protection against harmful interference in a residential installation. This equipment generates, uses and can radiate radio frequency energy, if not installed and used in accordance with the instructions, may cause harmful interference to radio communications.

However, there is no guarantee that interference will not occur in a particular installation. If this equipment does cause harmful interference to radio or television reception, which can be determined by turning the equipment off and on, the user is encouraged to try to correct the interference by one or more of the following measures:

- Reorient or relocate the receiving antenna.
- Increase the separation between the equipment and receiver.
- Connect the equipment into an outlet on a circuit different from that to which the receiver is connected.
- Consult the dealer or an experienced radio/TV technician for help.

## Contents

Introduction	1
Warnings	2
Parts Diagram	6
Battery Instruction	7
Getting Started	10
Battery Use	14
Mount	17
Camera Assembly	18
Care & Maintenance	19
Technical Specifications	20



Discarded electrical appliances are recyclable and should not be discarded in the domestic waste! Please actively support us in conserving resources and protecting the environment by returning this appliance to the collection centers (if available).



User manual is also available in PDF format, contact your local distributor to a copy if needed.

## Introduction

The dual thruster NAUTICA J-CLASS is a full-featured Seascooter that gets you cruising underwater with a top speed of up to 5mph (8km/h). Easily shift between 3 rotational speeds as you conserve your energy for more bottom time.

**Use appropriate equipment such as wetsuit, approved life jacket, mask & snorkel etc. when using Seascooter.**

**Only operate the Seascooter in water.**

- Innovative patented foldable design provides excellent carry-on travel qualities and compact storage size
- Water -proof patented motor built for extended use
- Durable watertight construction
- Runs up to 40 minutes
- Rated to 130ft / 40m
- Speed up to 5 MPH / 8 KM/H
- 3-level rotational speed control
- LCD display with battery level and Gear indicator
- Powered by high performance replaceable Lithium-Ion battery
- Weighs only 15 lb / 6.8 kg including battery



The Seascooter is designed for use in seawater. It will have less buoyancy in fresh water, lake or pool and may sink in such waters.



## WARNING

- Keep the manual since it contains important information.
- When passing on this device, include the user manual and all relevant warning information and parts.
- It is the responsibility of the owner to give proper instruction and precaution (regarding the risk associated with this device) when lending the device to other people.



# WARNING



- A child under 16 years old should never operate this product.
- The Seascooter is designed for 1 person use.



- This is not a life saving device. DO NOT use it as a buoyancy aid.



- Read the User Manual carefully before using the product.



- Always ensure sufficient charge remains in the battery to return to the shore surface before using the Seascooter.



- Do not use alcohol or mind-altering drugs prior to and during use of this product.



- ALWAYS inspect the swimming area to ensure it is free of hazards or obstacles such as boats or swimmers before using the Seascooter.



- Be aware of appropriate water levels, tidal changes, dangerous currents, weather change and strong offshore winds. ALWAYS scout unfamiliar water before venturing out.



- Crushing / Cutting Hazard



- Do not attach your body, clothing, other equipment to the seascooter in any way.



- ALWAYS wear a life vest (personal floatation device - PFD) approved by your local authorities for Snorkeling (U.S. Coast Guard Type III vest in the US or Canadian Coast Guard approved life vest in Canada or SAI Approval PFD in Australia or CE Approved PFD in Europe).



- Never place body parts, clothing or other objects in the vicinity of the propeller. Do not wear loose or flowing clothing or equipment that could be drawn into the propeller.



- Particular care should be exercised when using the Seascooter near anybody with long hair. Users with long hair should tie it up or wear a swimming cap when using the Seascooter.



- Be careful when you are transporting the Seascooter and setting it down to avoid crushing hazard on hands, foot or toes.

## **CAUTION**

- NEVER remove the grilles except for maintenance.
- Familiarize yourself with the Seascooter functions and battery life before embarking on any dives or excursions.
- Always charge battery to its fullest before using the Seascooter.
- Do not allow sun tan oils or lotions to be in prolonged contact with the Seascooter plastic as it may cause the plastic to become brittle and break apart.
- ALWAYS keep the Seascooter out of direct sunlight when not in use. HEAT KILLS BATTERIES AND IT MAY EXPLODE OR LEAK.
- Never open the Battery Compartment of the Seascooter in the water.
- When not in use, always turn the Master Switch to the OFF position.
- Do not use the Seascooter below the recommended maximum depth of 130ft / 40m.
- This machine is not intended for mixing or working with sand, concrete and material with similar physical characteristics. This machine is only intended for swimming and diving in the water.
- Do not use the unit if it is damaged in any way.
- Replace the battery immediately if it is damaged.
- The Seascooter should only be used for scuba diving by qualified divers.
- When using the Seascooter for scuba diving, ascents and descents should be made in accordance with recognized diving practices.

- Due to safety considerations those who have not obtained a C-Card (attesting to completion of training) from an entity providing diving instruction must not under any circumstances use this product for diving.
- In different waters (seawater, lake, pool) and conditions such as currents, temperature and pressure can affect the buoyancy of the unit which may cause the unit to sink if accidentally released.
- DO NOT release or leave the Seascooter in the water. Always take the unit out of water when not in use.
- Adequate lighting shall be used when using the Seascooter in dark waters and during night diving.
- Before each use, always check the handles are in locking place.
- Always check that your Seascooter works properly before use.

## **CRUSHING HAZARD:**

The following action during assembly, disassembly, and transportation of the Seascooter may incur crushing hazards to your fingers or toes:

- Opening and closing the foldable control handles.
- Installing the battery.
- Setting down the Seascooter or battery.
- Accidental dropping of the Seascooter or Battery.

## Parts Diagram

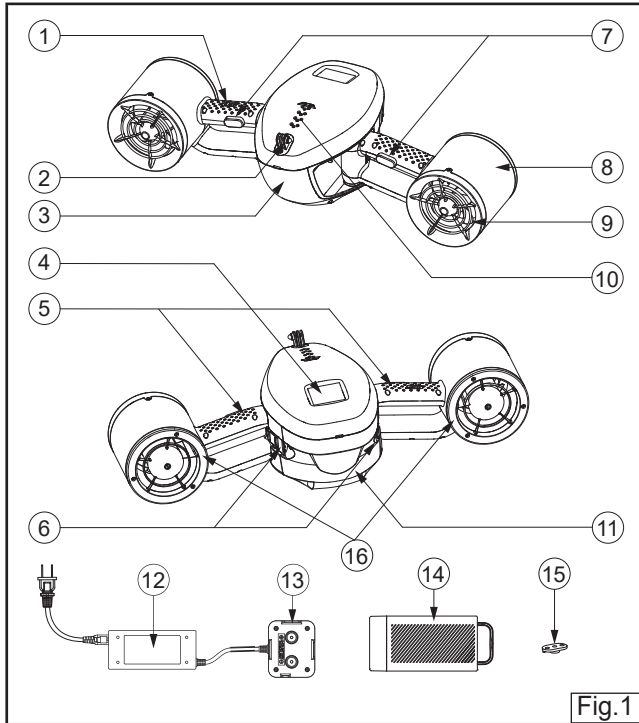

Fig.1

- |                     |                        |
|---------------------|------------------------|
| 1. Master Switch    | 9. Safety Net          |
| 2. Camera Mount     | 10. Indicators         |
| 3. Main Body        | 11. Battery Door       |
| 4. LCD Screen       | 12. Charger            |
| 5. Foldable Handles | 13. Charging Base      |
| 6. Handle Locks     | 14. Battery            |
| 7. Start Buttons    | 15. Multipurpose Mount |
| 8. Thruster         | 16. Propellers         |

6

## Battery Instruction



## WARNING

Replace the battery immediately if it is damaged.

- The instructions concerning persons (including children) with reduced physical, sensory or mental capabilities, or lack of experience and knowledge and children playing with the appliance are not applicable.
- The connector must be removed before the appliance is cleaned and that the appliance inlet must be dried before the appliance is used again.
- Detachable power supply part shall be provided with the part of class III construction of the appliance.
- The transformers or battery chargers used with the product are to be regularly examined for damage to the cord, plug, enclosure and other parts, and in the event of such damage, they must not to be used until the damage has been repaired.

### Charging instruction

- 1) Connect the battery pod to the charging base (Fig.2)
- 2) When charging, LED light of the charger turns Red (Fig.2)
- 3) Charging will take around 3-4 hour. When the battery is fully charged, LED light turns Green (Fig.2)
- 4) When battery is fully charged, unplug the charger from the mains (wall socket) and remove the battery from charging base.

7

# Battery Instruction

## Battery installation:

- 1) Ensure the master switch is in off position (Fig.11).
- 2) Always ensure the seascooter is out of water, dry and placed in dry area.
- 3) Release the battery door locking screw according to Fig.3 step 1.
- 4) Slide out the battery door (Fig.3 step 2).
- 5) Make sure the terminals 0-rings on the battery and battery compartment are in its position, clean and dry (Fig.9).
- 6) Align the groove on the battery and the tongue inside the battery compartment, slide in the battery (Fig.4).
- 7) Lock the battery (Fig.5 step 1,2,3).
- 8) Close the battery door (Fig.6 step 1).
- 9) Lock the battery door (Fig.6 step 2).

## To remove the battery for charging:

- 1) Unlock the battery (Fig.7 step 1,2).
- 2) Pull out the battery (Fig.8).

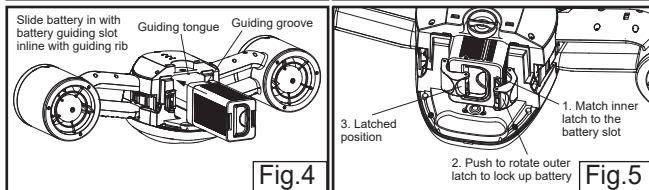
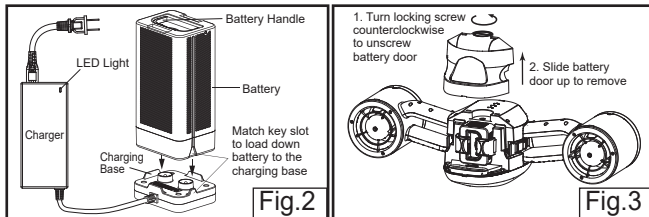

8

# Battery Instruction

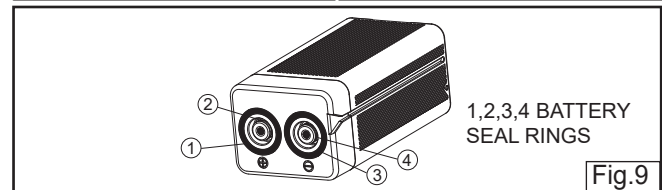
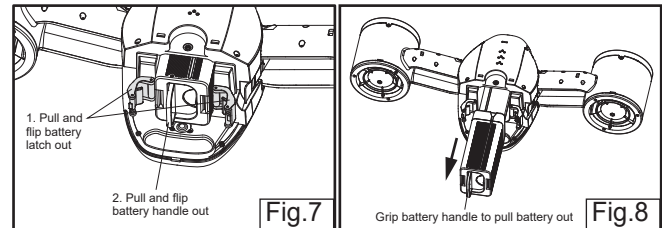
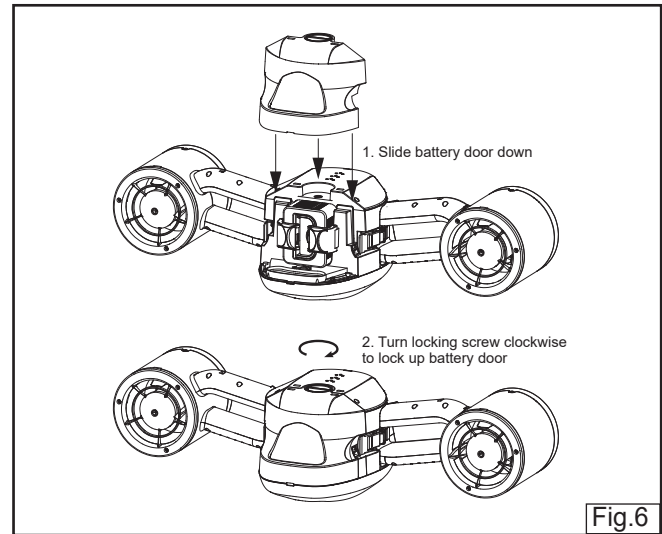

9

## Getting Started

# WARNING

Keep fingers away from gaps when folding the seascooter.

1. After battery installation, fold out the seascooter (Fig.10 step 1,2).
2. Lock the folded-out handles with the metal clips (Fig.10 step 3,4,5).
3. Slide the master switch to on position (Fig.11).
4. LCD dashboard will be switched on once master switch is in on position (LCD will be switched off if seascooter is idle for 8 minutes. Slide the Master Switch OFF and ON again to quit idle mode.)
5. Pull both triggers to start the propellers (Fig.11)
6. Release and press 1 trigger again to change the speed.

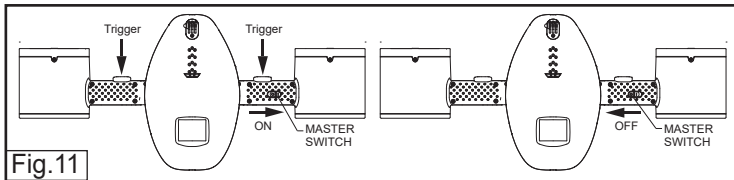
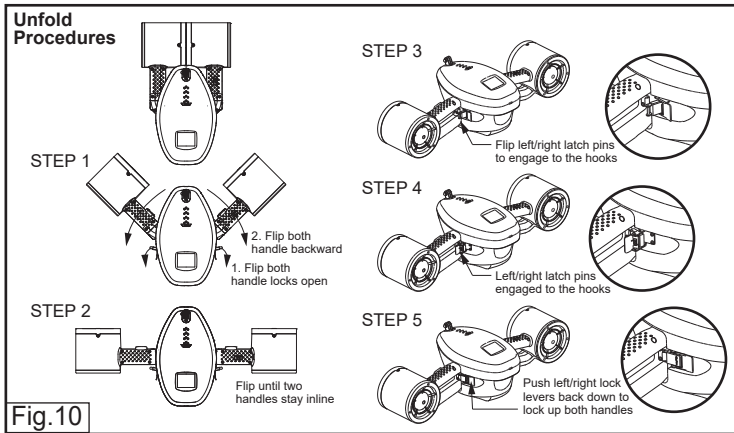

## Getting Started

Attention: (Refer to Fig.12)

- 1) Seascooter should only be run in water. It will only run for 3 seconds if in air. In such case "pictogram A" will be shown on the LCD screen
- 2) Seascooter should only be triggered when the handles are fully folded out. Otherwise, "pictogram B" will be shown on the LCD screen.
- 3) Seascooter should only be triggered when the propeller grilles are installed and locked. Otherwise, "pictogram C" will be shown on the LCD screen.

LCD display:

"pictogram A": When it is blinking, means you are not running the seascooter in water.

"pictogram B": When it is blinking, means the seascooter handles are not fully folded out.

"pictogram C": When it is blinking, means the grilles are not installed or locked.

"pictogram D": When it is blinking, means there is leaking of water in your seascooter. In such case, the motor will run for 9 seconds then stop for 1 second with beeping sound. Return to shore immediately and contact the service center for repair.

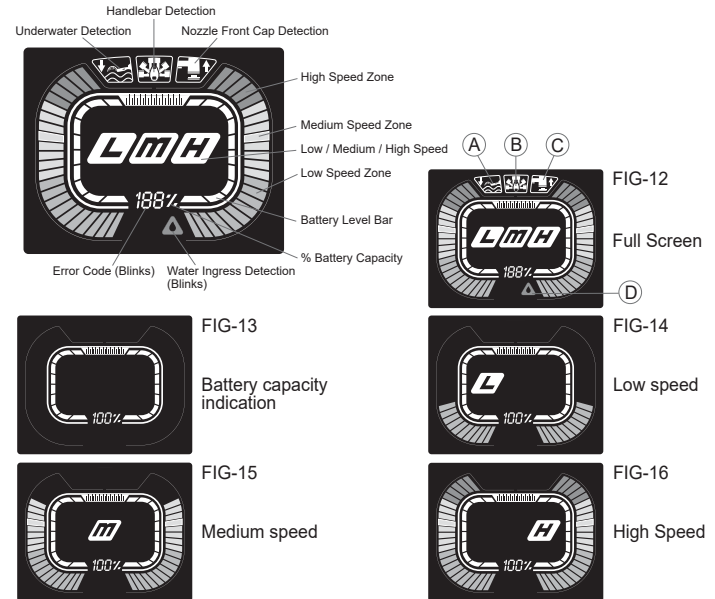





# WARNING

Do not put your hand or any other things into the propeller.

Notes:

1. If there is no operation for a long time, the product will be turned off automatically. Please turn off the master switch before you put it away.
2. Please do not replace the battery in water. Please remove the battery and clean the machine with fresh water after using, and keep the machine in cool and ventilated place.

Please use the machine correctly as shown and do not use in reverse.

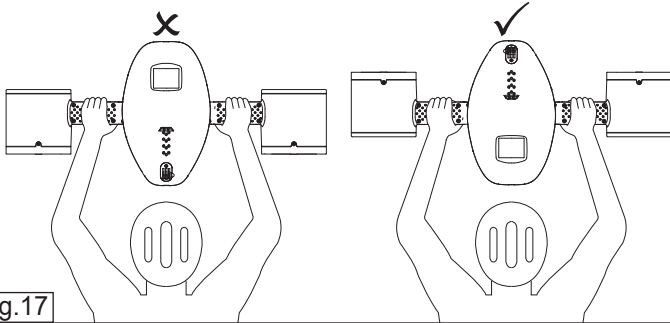

Fig.17

To fold up and hand carry the seascooter:

- Press and hold the clip on the middle of metal lock, then pull out the lock according to Fig.18 step 1,2,3.
- Fold the handles to the front (Fig.18 step 4,5).
- Carry the seascooter with the carry handle (Fig.19).

### Fold Procedures

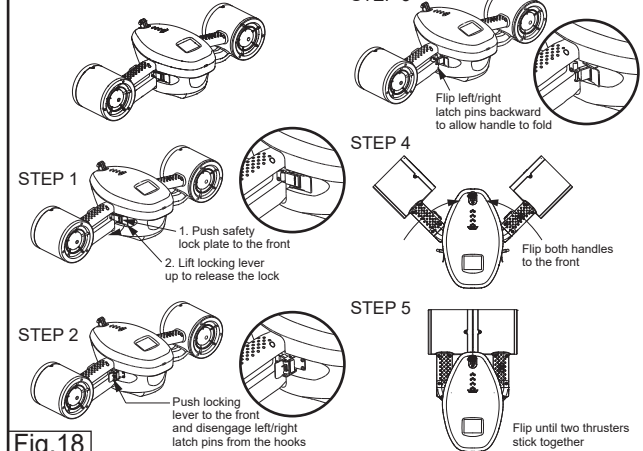

Fig.18

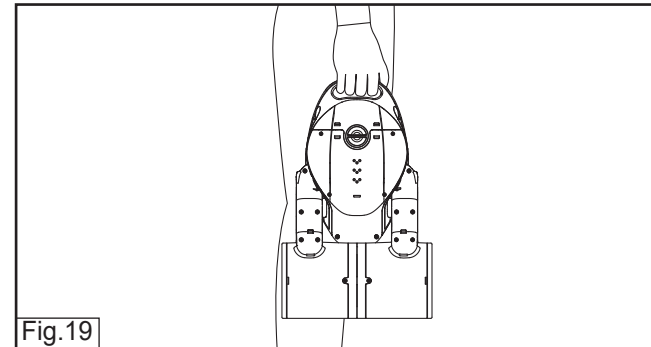

Fig.19

**CAUTION****WARNING  
BATTERY SAFETY****RE-CHARGE THE BATTERY  
AT LEAST****6 EVERY  
MONTHS**

- **MUST** re-charge the battery after **EACH USE.**
  - **MUST** re-charge the battery at least **EVERY SIX MONTHS** when not in use.
- **ALWAYS REMOVE** the Battery from the seascooter **FOR STORAGE.**
  - Never leave Lithium-Ion batteries discharged for long - the batteries do self-discharge and the charge could drop low enough to damage the battery.
  - Keep Lithium-Ion batteries away from high heat - high temperatures may cause premature battery failure.
  - **ALWAYS** store Lithium-Ion batteries partially discharged in a cool, dry place.

[www.seascooter.net](http://www.seascooter.net)**CAUTION**

- Use the specified charger only.
- Must be disposed of properly.
- Do not incinerate, disassemble, damage, short-circuit or expose to heat.
- The battery contains safety and protection devices which, if damaged, may cause the battery to generate heat, rupture or ignite.
- **DO NOT THROW WATER ON A BURNING LI-ION BATTERY.** If an exposed battery does ignite, it will burn even more violently if it comes into contact with water or even the moisture in air. A fire extinguisher must be used.
- Do not expose the battery to water or salt water, or allow the battery to get wet when seascooter is not in use.
- Do not subject the battery to strong impacts or shocks.
- Do not pierce the battery with nails, strike the battery with a hammer, step on the battery, or otherwise damage the outer casing.
- **MUST** re-charge the battery after **EACH USE.**
- **MUST** re-charge the battery at least **EVERY SIX MONTHS** when not in use.



# CAUTION

- **ALWAYS REMOVE** the battery from the Seascooter **FOR STORAGE**.
- Never leave Lithium-Ion batteries discharged for long - the batteries do self-discharge and the charge could drop low enough to damage the battery.
- Always store the battery partially discharged in a cool, dry and well-ventilated areas where it is out of reach of children and away from ignition sources.
- Do not place the battery in fire, direct sunlight or other high temperature locations. Do not apply heat to the battery. Doing so may cause the battery to generate heat, rupture, or ignite. Using the battery in this manner may also result in a loss of performance and a shortened life expectancy.
- Always keep the battery terminals clean.
- To prevent short-circuiting or fire, keep the battery away from other metal objects when carrying or storing.
- To prevent short-circuiting or fire, always ensure the charging area is safe during charging.

J-CLASS comes with a camera mount and a multi-purpose mount. Install and exchange the mount according to below diagram.

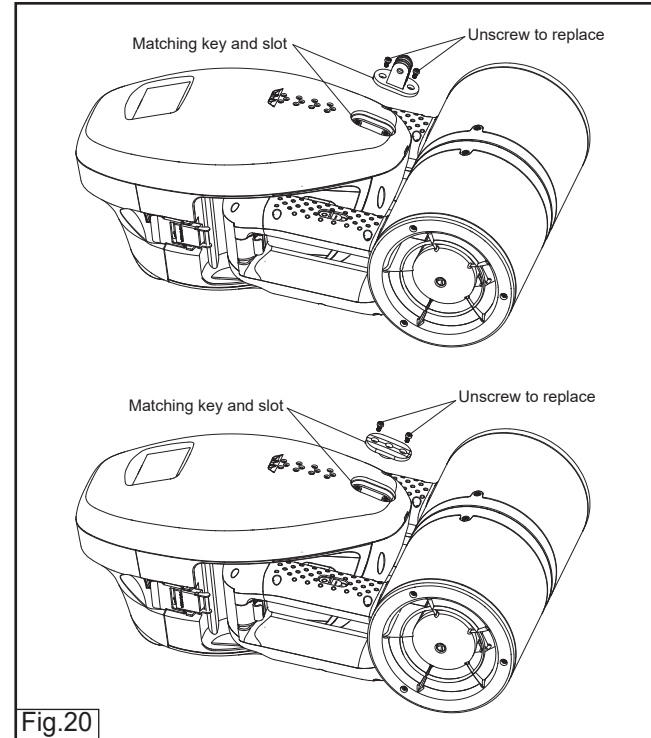

## Camera Assembly

### ATTACHING YOUR CAMERA TO SEASCOOTER MOUNTS

(Can be used with GoPro® HERO [3, 3+, 4, 5, 6 or 7] cameras, or other camera with using the same mount system)

To attach your camera to Seascooter J-CLASS, you will need a thumb screw or hardware depending on the mount you are using.

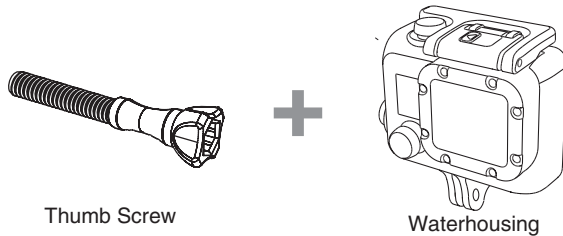

Thumb Screw

Waterhousing

Simply attach the Camera to the mount and align the hole, Insert And Tighten Up The Thumb Screw

\*Camera (and Waterhousing), Attachment Buckle and Thumb Screw are not included

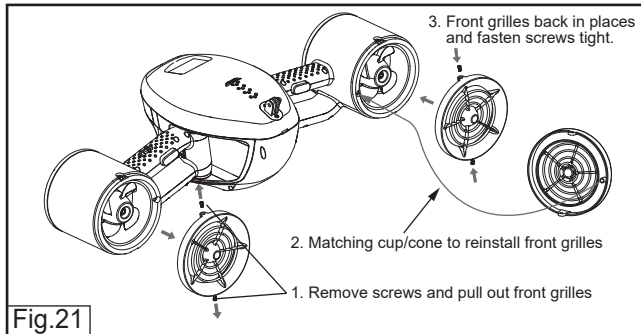

Fig.21

## Care & Maintenance

### Washing and Care

- After each use, immerse the seascooter into a container filled with freshwater for 20 minutes. Then switch on the seascooter in low speed for 3 seconds, and repeat this function 5 times to wash away dirt and salt from the product and motor.
- Dry the seascooter after washing. To dry the seascooter, remove the battery and leave the battery door opened. Turn the seascooter in different angles to drain the water. Use a dry cloth to dry the seascooter. Put the seascooter in a cool and ventilated area overnight for drying.
- Make sure the seascooter is fully dry before storage.
- To clean the Seascooter do not use detergents; only use a damp cloth to wipe the unit clean.
- Use a cloth to dry the Seascooter and the battery compartment.
- DO NOT leave the Seascooter in the water. Always take the unit out of water when not in use.

### Blocked Propeller

If the Propeller becomes blocked, you can remove the front grille to remove an obstruction. Below steps must be following to avoid injury.











(Under normal use the grilles must not be removed.)

1. Remove the SEASCOOTER from the water.
2. Make sure the master switch is in the Off position.
3. Dry the seascooter and remove the battery.
4. Open the grille according to the Fig.21 step 1.
5. Remove obstruction.
6. Reassemble grille (Fig.21 step 2,3).

### Sand or Grit on Seals

Ensure that sand/grit does not get on the seals as correct maintenance and care is essential. To remove sand or grit from the seals, rinse the seals in fresh water and apply fresh lubricant. If there is sand inside the Battery Housing, gently brush the sand from the unit taking care not to scratch the sealing surfaces.

## Technical Specifications

 WEIGHT 15 LB / 6.8 KG	 16+	 DEPTH 130 FT / 40 M	 RUN TIME 40 MINUTES
 SPEED UP TO 5 MPH / 8 KM/H	 GEAR 3 SPEED	 RECHARGE 3-4 HOURS	 BATTERY 22.2V / 6 AH
 SIZED FOR CARRY-ON TRAVEL			

Unit Dimensions	26.2 inches x 6.7 inches x 11.8 inches 665 x 170 x 300 mm
Unit Weight	15 lb (6.8 kg)
Battery Type	1 x 22.2V / 6 AH rechargeable battery
Battery Life / Fully Charge	Runs up to 40 minutes with normal use. Continuous use up to 30 minutes.
Speed	Up to 5 mph (8 km/h)
Depth rating	40 m / 130 ft (Maximum advised depth rating for recreational diving)

### \*Normal Use

The definition of normal use is based on the average general time of use the user activates the Seascooter in the water.

### △Continuous Use

The definition of continuous use is based on a fully charged battery whereby the Seascooter is used continuously in the water without stopping.

For more information on  
**Seascooter™ Products**  
(Warranty, Customer Care / Maintenance,  
Parts & Battery Purchase)

**PLEASE VISIT**  
**www.Nauticaseascooters.com**

All corresponding specification appear in this manual are correct at the time of printing.  
For the latest updates and further information on the complete range of the Seascooter™,  
PLEASE VISIT [www.Nauticaseascooters.com](http://www.Nauticaseascooters.com)

This Product is not manufactured by Nautica. For consumer purposes,  
please contact Sport Dimension Inc. at 1-800-678-7873.

(US & CANADA MARKET ONLY)

Please visit our website at [www.Nauticaseascooters.com](http://www.Nauticaseascooters.com) to find out your local distributor.

### Products covered by the following patents:

USA, Canada, EU, Australia, Japan, Hong Kong, China & Turkey  
US D471,506S / US D518,768S / D527,702S / US D506,176S / US D507,776S  
D512,678S / D519,911S / 6848385 B2 / US 7000559 B2 / US 7093554 B1 / 11/102,302  
0500577.8 / 0500578.0 / 0500579.2 / HK1072691 / ZL200530005661.5  
ZL200430079550.4 / ZL200430057359.X / ZL200530005662.X / ZL200530005663.4  
ZL200320103738.8 / ZL200520008894.5 / 1194933 / 1254107 / 1225250  
000330311-0001 / 000183900-0001 / 000183900-0002 / 000330279-0001  
000330295-0001 / 03020902.7 / 302949 / 302564 / 302563 / 302950  
302948 / 2005100230 / 200503474 / 29/268,724 / 11/595,675 / 000816376-0001

### US & CANADA MARKET ONLY

Toll Free (US) : 1-800-678-7873

[info@nauticaseascooters.com](mailto:info@nauticaseascooters.com)

**[www.Nauticaseascooters.com](http://www.Nauticaseascooters.com)**

Nautica™ and ™ are trademarks of Nautica Apparel, Inc.

©Nautica Apparel, Inc. [nautica.com](http://nautica.com)

Patented

Print in China

**In addition, this warranty does not cover items that experience normal wear and tear.**

ALL IMPLIED WARRANTIES ARE LIMITED IN THE DURATION TO THE WARRANTY PERIOD. AND SUCH IMPLIED WARRANTIES INCLUDING MERCHANTABILITY, FITNESS FOR A PARTICULAR PURPOSE, OR OTHERWISE, ARE DISCLAIMED IN THEIR ENTIRETY AFTER THE EXPIRATION OF THE APPROPRIATE WARRANTY PERIOD. THE DISTRIBUTOR'S OBLIGATION UNDER THE WARRANTY IS STRICTLY AND EXCLUSIVELY LIMITED TO THE REPAIR OR REPLACEMENT OF DEFECTIVE PARTS AND RETURN OF THE PRODUCT TO THE CUSTOMER. THE DISTRIBUTOR DOES NOT ASSUME OR AUTHORIZE ANYONE TO ASSUME FOR THEM ANY OTHER OBLIGATION.

THE DISTRIBUTOR ASSUMES NO RESPONSIBILITY FOR INCIDENTAL, CONSEQUENTIAL OR OTHER DAMAGES INCLUDING, BUT NOT LIMITED TO EXPENSE OF RETURNING THE PRODUCT TO THE DISTRIBUTOR, LOSS OF USE OF PRODUCT AND LOSS OF TIME OR INCONVENIENCE.

**THIS PRODUCT IS DESIGNED AND INTENDED FOR PERSONAL RECREATIONAL USE ONLY!**

**THIS PRODUCT IS NOT WARRANTED FOR COMMERCIAL OR RENTAL USE!**

**REPAIR WORK OR DELIVERY OF A REPLACEMENT DOES NOT EXTEND OR RENEW THE WARRANTY PERIOD.**

**WARRANTY SHALL AUTOMATICALLY BE VOID IF DAMAGE IS RESULT OF NON-ORIGINAL PARTS.**

**LIMITED WARRANTY for seascooters with camera mount:**

- ALWAYS inspect to ensure the product works properly every time before use. Warranty of this product does not cover any damages due to misuse.
- Failure to follow the user(s) instructions on packaging and/or user(s) manual may result in damages or loss of your cameras including but not limited to any user's personal items, all of which are not covered under warranty of this product.
- Use at your own risk. Manufacturer(s) and/or suppliers/agents are not responsible for any damages/repairs, loss to cameras/electronic items including but not limited to any user's personal items directly and/or indirectly resulted in the use of this product. Damage(s) resulting from any use, misuse, accident, and normal wear and tear are understandably not covered under this product warranty nor be responsible by manufacturer(s) and/or suppliers/agents.

#### **EXCLUSIONS**

**BATTERY.** This warranty does not include the battery.

Never replace the original SEASCOOTER BATTERY with an AFTERMARKET BATTERY. Seascooter with aftermarket battery will not be covered by this warranty.

#### **CUSTOMER ENQUIRIES**

If your unit is not operating, please refer to your User Manual before contacting our Customer Service Center. For any damage or repair work required, please do not return your product to the store where it was purchased.

#### **RETURN / REPAIR POLICY**

Customers must contact their Local Distributor Service Center to ask for an official Claim Form. The Claim Form must be returned with the customer's contact details and a photo of the Seascooter, defective parts, the serial number and the Original Purchase Receipt. The Distributor Customer Service Center will review the case and issue a Return / Repair Authorization Number before sending the product to the Distributor Service Center. Returned products must be shipped with original packaging including the polystyrene packing material and all defective parts. Please contact your Local Distributor Service Center for assistance in handling your case.

**Please visit our website [www.Nauticaseascooters.com](http://www.Nauticaseascooters.com) for a listing of most update distributor contacts and service center contacts.**

#### **RETURN / REPAIR PROCEDURE**

1. Call the Customer Service Center for your Return / Repair Authorization Number.
2. Make a copy of your Proof of Purchase (receipt).
3. Pack the defective unit in its original packaging including the polystyrene foam and include the unit and all defective parts.
4. Attach the copy of your Proof of Purchase (receipt) to the outside of the box (clearly visible), together with the Return / Repair Authorization Number.
5. Ship the package to the Service Center on your cost.

**PLEASE NOTE:** Deliveries that do not have the Proof of Purchase (receipt) and Return / Repair Authorization Number attached clearly to the outside of the box, will not be accepted by the Service Center.

---

**For any questions or queries you may have regarding your SEASCOOTER™, please follow the below steps for easy and fast resolution:**

---

##### **- STEP 1-**

Please read your User Manual. For a copy of the User Manuals, please visit [www.Nauticaseascooters.com](http://www.Nauticaseascooters.com)

##### **- STEP 2-**

Go to [www.Nauticaseascooters.com](http://www.Nauticaseascooters.com) and see our FAQ section to find instant answers.

##### **- STEP 3-**

Contact one of our Customer Service representatives at the Customer Service Center in your region.