



**OWNER'S MANUAL
PRODUCT CODE: 2015**

12,000kg HYDRAULIC BOTTLE JACK



Lifting Capacity	Max. Lifting Height	Min. Lifting Height	Hydraulic Lift	Screw Adjustment	Base Area
12,000kg	350mm	180mm	100mm	70mm	157 x 134mm

WARNING INFORMATION

IMPORTANT: READ ALL INSTRUCTIONS BEFORE USE



WARNING

The instructions and warnings contained in this manual should be read and understood before using or operating this equipment. Do not allow anyone to use or operate this equipment until they have read this manual and have developed a thorough understanding of how this equipment works. Failure to observe any of the instructions contained in the manual could result in severe personal injury to the user or bystanders, or cause damage to the equipment and property. Keep this manual in a convenient and safe place for future reference.

Whilst every effort has been made to ensure accuracy of information contained in this manual, the Tradequip policy of continuous improvement determines the right to make modifications without prior warning.

CONTENT

WARNING INFORMATION	2
CONTENT	2
SAFETY INSTRUCTIONS	3
ASSEMBLY, OPERATION & PREVENTATIVE MAINTENANCE	4
PARTS LIST	8
TROUBLESHOOTING	9
WARRANTY	10

SAFETY INSTRUCTIONS



SAFETY OPERATING INSTRUCTIONS

- ✓ Check vehicle owner's manual for correct vehicle weight.
- ✗ DO NOT exceed the bottle jacks rated safe working capacity.
- ✗ DO NOT modify this jack.
- ✓ Use only as specified by the manufacturer.
- ✓ The bottle jack is a lifting device only. Immediately after lifting, support the vehicle with appropriate means.
- ✓ Use only on a hard, flat, level surface.
- ✓ Securely chock wheels remaining on the ground.
- ✓ Ensure that each stand is securely located under a strong point on the vehicle - consult vehicles owner's manual for guidance.
- ✓ Centre the load prior to lifting.
- ✓ For your safety, do not modify or alter this Bottle Jack.
- ✓ When servicing, use only Tradequip identical replacement parts. Use of any other parts will void the warranty.
- ✓ Use the right product for the job. There are certain applications for which the Bottle Jack was designed. Do not modify the Bottle Jack and do not use the Bottle Jack for a purpose for which it was not intended.

ASSEMBLY, OPERATION & PREVENTATIVE MAINTENANCE

1. FEATURES

The Tradequip Hydraulic Bottle Jack is designed specifically for lifting and lowering, but not sustaining load. This unit provides enough lifting power for use with most automotive and farm vehicles, heavy duty machinery, industrial construction equipment and more. It's low profile design get's you out of tight situations with ease.

2. BEFORE USE

Conduct a thorough visual inspection checking for any abnormal conditions, such as cracked welds, and damaged, loose, or missing parts. Bleed any trapped air from the hydraulic system by performing the air purge procedure below.

Purge Air:

Purge the hydraulic system of air. During transit the unit may become "air-bound", causing a spongy ram action. To purge the system;

1. Turn the release valve counter clockwise one full turn with the handle provided
2. Rapidly pump the handle 12-18 times. Leave the handle in the down position
3. With a flat blade screwdriver, push the oil filler plug slightly to the side to release trapped air from the system (Careful not to tear or puncture rubber plug)
4. Turn the release valve clockwise to the closed position
5. Check for functional pump action
6. If unsatisfactory, required repeat steps 3 through 6 again (as many as 4 to 5 times)

Check Oil Level:

1. With the jack on level ground, in an upright position and the ram completely retracted, open the release valve (turn counter-clockwise) and remove the filler plug.
2. The oil level should be just beneath the filler hole.
3. Fill if necessary top up with good quality hydraulic jack oil
(*TQB Brands Pty Ltd recommends using Penrite Hydraulic Jack Oil*)
4. Perform Purge Air procedure above

3. OPERATION

Prior to each use always conduct a visual inspection checking for and any abnormal conditions, such as cracked welds, and damaged, loose, or missing parts.

The Jack operates when the release valve is closed, an upward stroke of the jack handle draws hydraulic oil from the reservoir tank into the plunger cavity. A downward stroke of the jack handle releases hydraulic oil into the cylinder, which forces the ram up. This raises the saddle. When the ram reaches its maximum extension, oil is bypassed back into the reservoir to prevent over extended ram and possible damage to the jack. Opening the release valve allows oil to flow back into the reservoir. This releases hydraulic oil pressure on the ram, which results in the lowering of the saddle.

To Lift the Vehicle:

1. Block the vehicle's wheels for lifting stability. Secure the load to prevent inadvertent shifting and movement.
2. Position the jack near the specified lift point.
3. Set the parking brake in the vehicle.
4. Refer to the vehicle manufacturer owner's manual to locate approved lifting points on the vehicle. Position the jack so the saddle is centred and will contact the load lifting point firmly
5. Close the release valve by turning it clockwise until it is firmly closed.
6. Before raising the vehicle double check and verify the saddle is centred and also has full contact with the lifting point.
7. Pump the handle to lift until the saddle makes contact with the vehicle. Then continue to pump the jack handle to lift the vehicle to the desired height. Then immediately support the load with the appropriately rated jack support stands before working on the vehicle.

To Lower Vehicle:

1. Turn the release valve counter-clockwise to the closed position.
2. Raise load high enough to allow clearance for the jack stands to be removed, then carefully remove jack stands.
3. DO NOT get under or let anyone else under vehicle whilst lowering.
4. Carefully turn the release valve knob SLOWLY counter clockwise to lower vehicle onto the ground.

4. MAINTENANCE

If you use and maintain your equipment properly, it will give you many years of service. Follow the maintenance instructions carefully to keep your equipment in good working condition. Never perform any maintenance on the equipment while it is under a load.

Oil Level:

The level of oil should be maintained a maximum of 6mm below filler cap. Top up with quality hydraulic ISO VG32 oil. **DO NOT** use *brake/trans fluid or engine oil*. Regularly drop oil into the air supply inlet prior to use.

Inspection: Inspect the product for damage, wear, broken or missing parts (e.g: pins) and that all components function before each use. Follow lubrication and storage instructions for optimum product performance.

Binding: If the product binds while under a load, use equipment with equal or larger load capacity to lower the load safely to the ground. After un-binding clean, lubricate and test that equipment is working properly. Rusty components, dirt, or worn parts can be causes of binding. Clean and lubricate the equipment as indicated in the lubrication section. Test the equipment by lifting without a load.

Cleaning: If the moving parts of the equipment are obstructed, use cleaning solvent or another good degreaser to clean the equipment. Remove any existing rust, with a penetrating lubricant.

Lubrication: This equipment will not operate safely without proper lubrication. Using the equipment without proper lubrication will result in poor performance and damage to the equipment. Some parts in this equipment are not self-lubricating. After cleaning, lubricate the equipment using a high grade light penetrating oil or lubricating spray.

- Use a good lubricant on all moving parts
- For light duty use lubricate once a month
- For heavy and constant use lubrication is recommended every week.
- NEVER use sandpaper or abrasive material on these surfaces.

Rust Prevention: Check rams and pump plungers on the power unit assemblies daily for any signs of rust or corrosion. Without a load on the equipment extend hydraulic rams to check if signs of rust are visible, clean as needed.

Storage:

- Always store the jack with the ram fully retracted
- Ensure the jack handle is in the up position
- Always store in a dry location, preferably indoors
-



**WARNING - Top up with quality hydraulic ISO VG32 oil.
DO NOT use brake/trans fluid or engine oil.**

5. SERVICE & REPAIR

Any Bottle Jack found damaged in any way, or found to be worn or operates abnormally should be removed from service until repaired by an authorised service agent. Owners and / or operators should be aware that repair of this product may require specialised equipment and knowledge. Only authorised parts, labels, decals shall be used on this equipment. Annual inspection of the Bottle Jacks is recommended and can be made by an authorised repair facility to ensure that your equipment is in optimum condition and that the equipment has the correct decals and safety labels specified by the manufacturer.

PARTS LIST

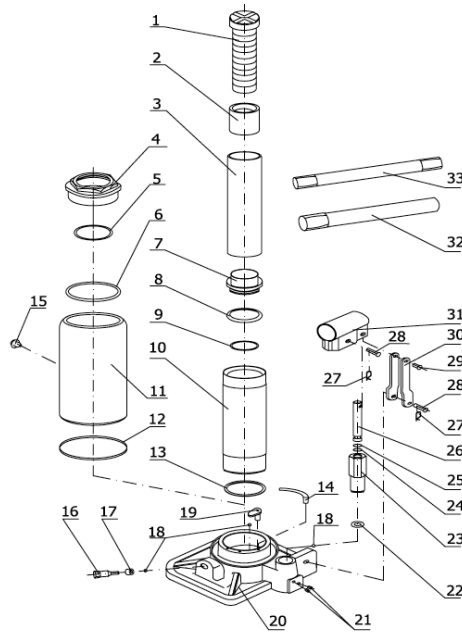

Part #	Description	QTY
1	Adjustable Saddle	1
2	Saddle Socket	1
3	Piston Rod	1
4	Nut	1
5	O-Ring (Nut)	1
6	Seal	1
7	Piston	1
8	Bowl Washer	1
9	O-Ring (Piston)	1
10	Cylinder	1
11	Reservoir	1
12	Reservoir Seal	1
13	Base Plate Washer	1
14	Filter Screen	1
15	Oil Filler Plug	1
16	Release Valve	1
17	Release Valve Seal	1

Part #	Description	QTY
18	Ball 6mm	3
19	Ball Stopper	1
20	Base	1
21	Bolt	2
22	Washer (Pump)	1
23	Pump	1
24	O-Ring (Plunger)	1
25	Back Ring	1
26	Plunger	1
27	R-Pin	1
28	Pin	1
29	Short Pin	2
30	Link Plate	1
31	Handle Socket	2
32	Handle Top	1
33	Handle Bottom	1

TROUBLESHOOTING

Problem	Cause	Solution
Jack will not lift	Release valve not tightly closed Overload condition Air in hydraulic system	Ensure release valve tightly closed Remedy overload condition Purge air from system
Jack bleeds off after lift	Release valve not tightly closed Overload condition Hydraulic unit malfunction	Ensure release valve tightly closed Remedy overload condition Contact place of purchase
Jack will not lower after unloading	Reservoir overfilled Linkages binding	Drain fluid to proper level Clean and lubricate moving parts
Poor lift performance	Fluid level low Air trapped in system	Drain fluid to fluid level With ram fully retracted, remove oil filler plug to let pressurised air escape reinstall oil filler plug
Will not lift to full extension	Fluid level low	Ensure proper fluid level

WARRANTY

Tradequip products have been carefully tested and inspected before shipment and are guaranteed to be free from defective materials and workmanship for a period of 12 months from the date of purchase except where tools are hired out when the guarantee period is ninety days from the date of purchase.

Should the machine develop any fault, please return the complete tool to your nearest authorised warranty repair agent or contact TQB Brands Pty Ltd Warranty team – warranty@tqbbrands.com.au.

If upon inspection it is found that the fault occurring is due to defective materials or workmanship, repairs will be carried out free of charge. This guarantee does not apply to normal wear and tear, nor does it cover any damage caused by misuse, careless or unsafe handling, alterations, accident, or repairs attempted or made by any personnel other than the authorised TQB Brands Pty Ltd repair agent.

This guarantee applies in lieu of any other guarantee expressed or implied and variations of its terms are not authorised.

Your TQB Brands Pty Ltd guarantee is not effective unless you can produce upon request a dated receipt or invoice to verify your proof of purchase within the 12 month period.

Consumer Guarantee

Our goods come with a guarantee that cannot be excluded under the Australian Consumer Law. You are entitled to a replacement or refund for a major failure and compensation for any other reasonably foreseeable loss or damage. You are also entitled to have the goods repaired or replaced if the goods fail to be of acceptable quality and the failure does not amount to a major failure.