

PRODUCT CATALOGUE 2020



NEW
PRODUCTS
ADDED FOR
2020!

Grade 8 Chain Slings
(BS EN 818-4)

Grade 8 Load Lashing Systems
(BS EN 12195)

Company Profile

Brindley Chains Ltd was established in 1984 as the sole UK distributor for Pewag Austria GmbH. Since then the company has established itself in the UK market as a leading supplier of high quality chain related products for a wealth of applications and industries.

Our product portfolio includes the complete range of Pewag chains and fittings for lifting and lashing, bucket elevator and conveyor systems, tyre protection and traction chains, a comprehensive range of stainless steel lifting products, lifting points / swivel hoist rings, plate lifting clamps, lifting magnets and DNV master links.

Pewag stainless steel pump lifting chains have become the benchmark for quality and safety in the water industry and are specified by many utility companies throughout the UK. Pewag Winner Inox G6 chains and fittings provide an increased WLL over traditional G50 stainless steel systems.

We can supply LINX-8 G8, Pewag Winner G10, Winner Pro G12 and Winner Inox G6 stainless steel ready assembled chain slings from stock which are usually despatched on the day of order via next day carrier.











In 2011 we were appointed UK main agents for Nitchi and Eller hoisting products which include manual and electric chain hoists, lever hoists, beam clamps, beam trolleys and wire rope pullers, as well as the ENDO range of tool / spring balancers.

Other products available from Brindley Chains include Black Pin Fed Spec shackles, DNV chain slings, hoist chains and hand chains, chains for hot dip galvanizing plants, forestry logging chain systems, tyre protection chains, snowchains, AutoSocks, security chains and padlocks.

The company is certified to BS EN ISO 9001:2015 Quality Standard and is an active member of the Lifting Equipment Engineers Association (LEEA).



Contacts







Paul Brindley	-	Director		07764 930901
Chris Brindley	-	Director		07764 930902
Gail Lee	-	Accounts		01925 825555
Michelle Brookes	-	Accounts assistant		01925 825555
Ian Baxter	-	Sales Engineer		07432 506768
Alan Starkey	-	Sales Engineer		07919 405608
Irene Walters	-	Sales Administration		01925 825555
Kathy Couzens	-	Sales Administration		01925 825555
Ruth Beaton	-	Sales Administration		01925 825555
David Cain	-	Sales Administration		01925 825555
Jeff Maskall	-	Warehouse Foreman		
Glynn Turner	-	Warehouse & Production		
Steven Bennett	-	Warehouse, Production & Site Service		

- Company Profile & Contact Information Page 2
- Load Charts Page 4
- Chains & Components Page 5
- Load Lashing Systems Page 13
- Spare Parts Page 17
- User Guide Page 18
- Chain Sling Builder App Page 21
- Accreditations Page 22

LINX-8 G8 Chain Slings (BS EN 818-4)

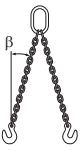
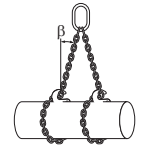
Load Capacities

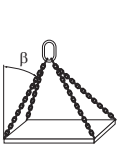
The load capacities shown are the **WORKING LOAD LIMITS** of the various sling types, stated according to the standard (Uniform Load) method of rating.

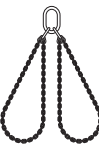
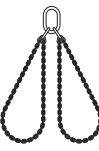
Factor of safety			Single leg chains		2 leg chains				3 and 4 leg chains		Endless chains	Basket chains	
4													
Working angles			-	-	0° - 45°	45° - 60°	0° - 45°	45° - 60°	0° - 45°	45° - 60°	-	0° - 45°	0° - 45°
Load factor			1	0.8	1.4	1	1.12	0.8	2.1	1.5	1.6	1.4	2.1
Ref	Grade	Dia.	Working load limits (tonnes)										
LINX 6	8	6mm	1.12	0.90	1.60	1.12	1.25	0.90	2.36	1.70	1.80	1.60	2.36
LINX 7	8	7mm	1.50	1.20	2.12	1.50	1.68	1.20	3.15	2.24	2.50	2.12	3.15
LINX 8	8	8mm	2.00	1.60	2.80	2.00	2.24	1.60	4.25	3.00	3.15	2.80	4.25
LINX 10	8	10mm	3.15	2.50	4.25	3.15	3.55	2.50	6.70	4.75	5.00	4.25	6.70
LINX 13	8	13mm	5.30	4.25	7.50	5.30	5.90	4.25	11.20	8.00	8.50	7.50	11.20
LINX 16	8	16mm	8.00	6.30	11.20	8.00	9.00	6.30	17.00	11.80	12.50	11.20	17.00
LINX 20	8	20mm	12.50	10.00	17.00	12.50	14.00	10.00	26.50	19.00	20.00	17.00	26.50
LINX 22	8	22mm	15.00	12.00	21.20	15.00	16.80	12.00	31.50	22.40	24.00	21.20	31.50
LINX 26	8	26mm	21.20	16.95	30.00	21.20	23.70	16.95	45.00	31.50	33.50	30.00	45.00
LINX 32	8	32mm	31.50	25.20	45.00	31.50	35.20	25.20	67.00	47.50	50.00	45.00	67.00

Manufactured fully in accordance with BS EN818-4.

If the chain slings are used in adverse conditions (e.g. high temperature, asymmetric load distribution, edge load, impact or shock loads) the maximum load capacity values in the table above must be reduced by the load factors below. Please also see the user information on this topic on page 16.

Demanding Conditions

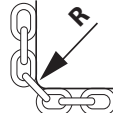
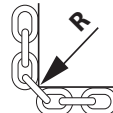
Temperature	-40°C to 200°C	Above 200°C to 300°C	Above 300°C to 380°C
Load factor	1	0.9	0.75
Asymmetric load distribution	The WLL has to be reduced by at least 1 leg. In case of any doubt only consider 1 leg as load-bearing.		
Edge loading	R = larger than 2 x chain diameter	R = larger than chain diameter	R = less than chain diameter
			
Load factor	1	0.7	0.5
Shock	Slight shocks	Medium shocks	Strong shocks
Load factor	1	0.7	Not permissible

LINX-8 G8 Chains & Components

G8 chain - Manufactured in accordance with BS EN 818-2

Proof load tested to 2.5 x WLL

Fatigue tested to 1.5 x WLL for 20,000 cycles

100% Magnaflux crack detected

Finished with black electrophoretic corrosion resistant coating

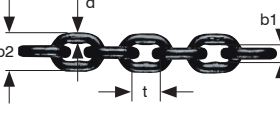
LINX-8 G8 round section chain with black electrophoretic coating (BS EN 818-2)	Code	WLL	Breaking force	Nominal diameter d	Pitch t	Inside width b1 min.	Outside width b2 max.	Full drum quantity	Weight
		[tonnes]	[kN]	[mm]	[mm]	[mm]	[mm]		
	BCL 6 EN	1.12	45.4	6	18	7.8	22.2	500	0.76
	BCL 7 EN	1.50	61.6	7	21	9.1	25.9	400	1.10
	BCL 8 EN	2.00	80.4	8	24	10.4	29.6	300	1.40
	BCL 10 EN	3.15	126	10	30	13	37	200	2.16
	BCL 13 EN	5.30	214	13	39	16.9	48.1	100	3.58
	BCL 16 EN	8.00	320	16	48	20.8	59.2	80	5.50
	BCL 20 EN	12.50	503	20	60	26	74	50	9.00
	BCL 22 EN	15.00	608	22	66	28.6	81.4	50	10.90
	BCL 26 EN	21.20	849	26	78	33.8	96.2	40	15.50
	BCL 32 EN	31.50	1290	32	96	41.6	118	25	24.10

G8 components - Manufactured in accordance with BS EN 1677

Proof load tested to 2.5 x WLL

Fatigue tested to 1.5 x WLL for 20,000 cycles

100% Magnaflux crack detected

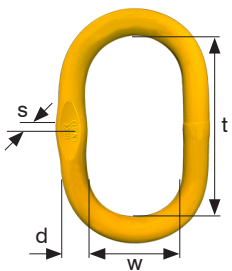
LM Master links (BS EN 1677-4)	Code	WLL 0-45°	d	t	w	s	Weight	Master link for chain Ø	
		[tonnes]	[mm]	[mm]	[mm]	[mm]		[mm]	[mm]
	LM0706	1.60	14	107	60	10.5	0.40	6 + 7	6
	LM0807	2.12	16	110	60	12.5	0.53	8	7
	LM1008	3.15	18	135	75	14.5	0.83	10	8
	LM1310	5.30	22	160	90	13.5	1.46	13	10
	LM1613	8.00	26	180	100	18.5	2.11	16	13
	LM1816	11.20	32	200	110	26	3.90	18	16
	LM2018	14.00	36	260	140	29	6.20	20	18
	LM2220	17.00	40	300	160	33.5	8.96	22	20
	LM2622	21.20	45	340	180	-	13.00	26	22
	LM3226	31.50	50	350	190	-	16.55	32	26
LM3632	45.00	56	400	200	-	23.28	-	32	

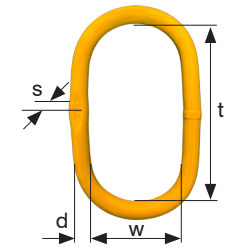
LME Oversized master links (BS EN 1677-4)	Code	WLL 0-45°	d	t	w	s	Weight	Master link for chain Ø	
		[tonnes]	[mm]	[mm]	[mm]	[mm]		[mm]	[mm]
	LME1310	5.80	22	270	140	15	2.29	13	10
	LME1613	8.00	25	270	140	20	3.04	16	13

**NEW
for
2020**

Please note that all dimensions stated are nominal and subject to change without prior notice!

LINX-8 G8 Chains & Components

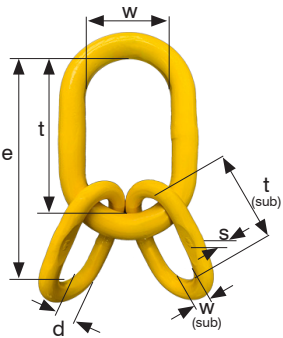
LA Quad master link assembly (BS EN 1677-4)	Code	WLL	e	t	w	d	t	w	s	Weight
		[tonnes]	[mm]	[mm]	[mm]	(sub) [mm]	(sub) [mm]	(sub) [mm]	(sub) [mm]	[kg/pc.]
	LA6	2.36	189	135	75	13	54	25	7	1.29
	LA7	3.15	195	135	75	13	60	38	7	1.35
	LA8	4.25	230	160	90	16	70	34	8	2.19
	LA10	6.70	265	180	100	18	85	40	11	3.20
	LA13	11.20	315	200	110	22	115	50	13	5.95
	LA16	17.00	400	260	140	26	140	65	17	9.51
	LA20	26.5	530	350	185	32	180	100	20	24.20
	LA22	31.50	530	350	185	36	180	100	-	25.45
	LA26	45.00	580	400	200	40	180	100	-	35.20
	LA32	63.00	660	460	250	50	200	110	-	66.46

LAE Oversized quad master link assembly (BS EN 1677-4)	Code	WLL	e	t	w	d	t	w	Weight
		[tonnes]	[mm]	[mm]	[mm]	(sub) [mm]	(sub) [mm]	(sub) [mm]	[kg/pc.]
	LAE7-8	5.80	420	270	140	16	150	75	3.66
	LAE10	11.80	410	270	140	20	140	70	5.92

**NEW
for
2020**

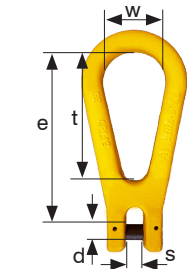
ARL Clevis reeving link (BS EN 1677-1)	Code	WLL	e	t	w	d	s	Weight
		[tonnes]	[mm]	[mm]	[mm]	[mm]	[mm]	[kg/pc.]
	ARL7-8	2.00	106	87	45	9	10	0.47
	ARL10	3.15	132	108	60	13	12	0.98
	ARL13	5.30	174	137.5	66.5	16	16.5	1.87
	ARL16	8.00	203	165	72	20	19	2.78

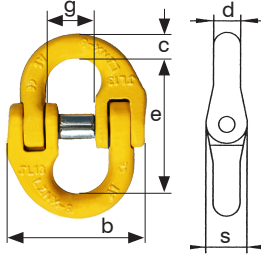

Please note that all dimensions stated are nominal and subject to change without prior notice!

LINX-8 G8 Chains & Components

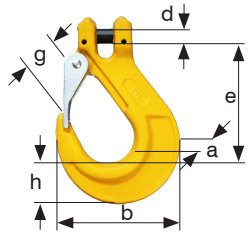
JL Connecting link (BS EN 1677-1)	Code	WLL	e	c	s	d	b	g	Weight
		[tonnes]	[mm]	[mm]	[mm]	[mm]	[mm]	[mm]	[kg/pc.]
	JL6	1.12	42	8.5	11.5	7	42	15	0.08
	JL7-8	2.00	60	9.5	13.5	8.5	55	18	0.14
	JL10	3.15	70	12.5	17.5	11	69	25	0.31
	JL13	5.30	87	15.5	24	15	83.5	29	0.63
	JL16	8.00	108	20	27.5	19.8	102	34.5	1.15
	JL20	12.50	115	25	36.5	23	116	40	1.96
	JL22	15.00	139	27	40.5	27	143	48	3.05
	JL26	21.20	158	31	44	30	174	58	4.50
	JL32	31.50	205	38	56	37	214	67.5	8.21

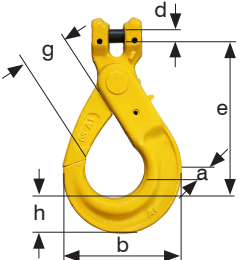
ASH Clevis sling hook with catch (BS EN 1677-1+2)	Code	WLL	e	h	a	d	g	b	Weight
		[tonnes]	[mm]	[mm]	[mm]	[mm]	[mm]	[mm]	[kg/pc.]
	ASH6	1.12	72	20	15.5	8	19.5	68	0.28
	ASH7-8	2.00	85	27.5	17	9	24	87.5	0.52
	ASH10	3.15	105	36	24	12	28	106	0.96
	ASH13	5.30	125	42	30.5	16	34.5	130	1.70
	ASH16	8.00	155	48.2	35	20	43	155.5	3.24
	ASH20	12.50	195	56	48.5	24	50	185	7.05
	ASH22	15.00	210	62	50.5	27.8	66	210	9.22
	ASH26	21.20	232	75	60	33	101	258	14.97
	ASH32	31.50	317	88	66	40.7	124	318	27

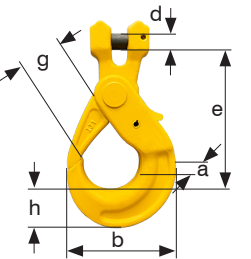
ALH Clevis safety hook (BS EN 1677-1+3)	Code	WLL	e	h	a	b	d	g	Weight
		[tonnes]	[mm]	[mm]	[mm]	[mm]	[mm]	[mm]	[kg/pc.]
	ALH6	1.12	96	20	17.5	70	8	27	0.47
	ALH7-8	2.00	123	26	21.5	90	9.5	35	0.84
	ALH10	3.15	144	30	27	109	13	45	1.47
	ALH13	5.30	182	40.5	33	138.5	16	52	3.01
	ALH16	8.00	217	50.5	40	170.5	20	64	5.36
	ALH20	12.50	235	54	50	190	24	76.5	7.78
	ALH22	15.00	270	68	53	205	28	77	11.85
	ALH26	21.20	312	75	60	239	33.5	96	21.8
	ALH32	31.50	416	97	79.5	329	40.7	135	49.6

ALS Clevis compact safety hook (for skips) (BS EN 1677-1+3)	Code	WLL	e	h	a	b	d	g	Weight
		[tonnes]	[mm]	[mm]	[mm]	[mm]	[mm]	[mm]	[kg/pc.]
	ALS10	3.15	123	30	28	93	13	37	1.08
	ALS13	5.30	146	39	29	112	16	44	2.13
									

Please note that all dimensions stated are nominal and subject to change without prior notice!

LINX-8 G8 Chains & Components

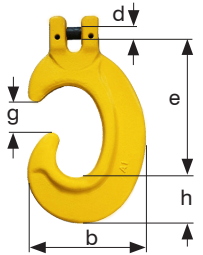
ACH Clevis C-hook (BS EN 1677-1)	Code	WLL	e	h	d	b	g	Weight
		[tonnes]	[mm]	[mm]	[mm]	[mm]	[mm]	[kg/pc.]
	ACH7-8	2.00	90	28	9.5	75	20	0.57
	ACH10	3.15	127	39.5	12	105	29.5	1.37
	ACH13	5.30	166.5	52	16	136	39.5	3.37
	ACH16	8.00	206	59	20	168	46.5	5.95

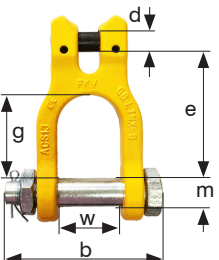
ACS Clevis shackle (BS EN 1677-1)	Code	WLL	e	b	d	w	m	g	Weight
		[tonnes]	[mm]	[mm]	[mm]	[mm]	[mm]	[mm]	[kg/pc.]
	ACS7-8	2.00	60.5	79.5	9.5	31	16	36	0.45
	ACS10	3.15	79	96	12	33.5	20	48	0.87
	ACS13	5.30	98	119	16	48	22	65	1.50
	ACS16	8.00	114	141	20	57	28.3	70	2.63

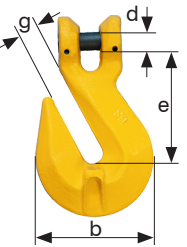
AGH Clevis grab hook (BS EN 1677-1)	Code	WLL	e	b	d	g	Weight
		[tonnes]	[mm]	[mm]	[mm]	[mm]	[kg/pc.]
	AGH6	1.12	44	45	8	8	0.19
	AGH7-8	2.00	53.5	50	9	10.8	0.33
	AGH10	3.15	75	72	12	13.5	0.77
	AGH13	5.30	90	95	16	16.5	1.71
	AGH16	8.00	100	108	20	19.2	2.71
	AGH20	12.50	125	135	24	22	4.84
	AGH22	15.00	140	160.5	26	25	7.62

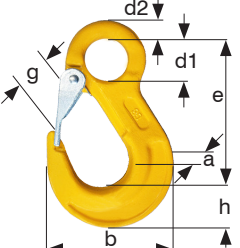
BSH Eye sling hook with catch (BS EN 1677-1)	Code	WLL	e	h	a	d1	d2	g1	b	Weight
		[tonnes]	[mm]	[mm]	[mm]	[mm]	[mm]	[mm]	[mm]	[kg/pc.]
	BSH6	1.12	78	20	15	20.5	9	18.5	68	0.26
	BSH7-8	2.00	95	27	18	25	11	22	84	0.48
	BSH10	3.15	118	33	24	34	14	28	102.5	0.84
	BSH13	5.30	149	40	32	42.5	17.5	35	128.5	1.84
	BSH16	8.00	183	48	38	52	22	43	156.5	3.06

Please note that all dimensions stated are nominal and subject to change without prior notice!

LINX-8 G8 Chains & Components

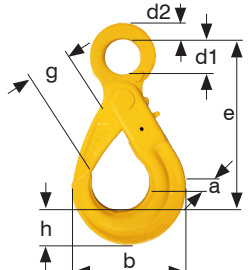
BLH Eye type safety hook (BS EN 1677-1+3)	Code	WLL	e	h	a	b	d1	d2	g	Weight
		[tonnes]	[mm]	[mm]	[mm]	[mm]	[mm]	[mm]	[mm]	[kg/pc.]
	BLH6	1.12	110	20	18	70	21	11	28	0.47
	BLH7-8	2.00	137	26	19.5	90	27	11	35.5	0.76
	BLH10	3.15	169	30	25	108	34.5	16	45	1.36
	BLH13	5.30	209	40.5	33	138.5	40	20	53.5	3.00
	BLH16	8.00	250	50.5	42	170.5	50	26	62	5.67

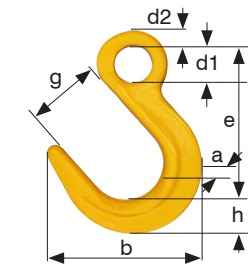
BFH Eye type foundry hook (BS EN 1677-1)	Code	WLL	e	h	a	d1	d2	g	b	Weight
		[tonnes]	[mm]	[mm]	[mm]	[mm]	[mm]	[mm]	[mm]	[kg/pc.]
	BFH8	2.00	120.5	29	20	24	11	62	130	0.71
	BFH10	3.15	153	34	26	31.5	16.5	73	152.5	1.37
	BFH13	5.30	184	40	32.5	44	19	90	186	2.48
	BFH16	8.00	216	44	38	49	23	105	218	4.15

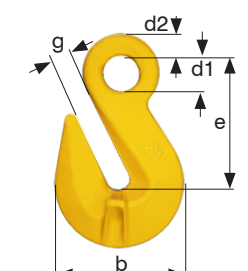
BGH Eye type grab hook (BS EN 1677-1)	Code	WLL	e	b	d1	d2	g	Weight
		[tonnes]	[mm]	[mm]	[mm]	[mm]	[mm]	[kg/pc.]
	BGH6	1.12	50	44	13.5	9	8	0.14
	BGH7-8	2.00	60	52	17	10	10.8	0.28
	BGH10	3.15	79	70.5	20	13.5	13	0.65
	BGH13	5.30	99	95	26	16	16.5	1.36
	BGH16	8.00	103	106	30	18	19.2	2.12
	BGH20	12.50	140	143	37.5	23	24	4.00
	BGH22	15.00	165	160	44	26	28	6.36
	BGH26	21.20	197	171	49	32	30	10.60
	BGH32	31.50	246	229	64	40	41	19.40

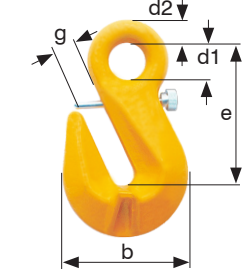
BGHS Eye type grab hook with safety pin (BS EN 1677-1)	Code	WLL	e	b	d1	d2	g	Weight
		[tonnes]	[mm]	[mm]	[mm]	[mm]	[mm]	[kg/pc.]
	BGHS7-8	2.00	60	52	17	10	10.8	0.28
	BGHS10	3.15	79	70.5	20	13.5	13	0.65
	BGHS13	5.30	99	95	26	16	16.5	1.36
	BGHS16	8.00	103	106	30	18	19.2	2.12

Please note that all dimensions stated are nominal and subject to change without prior notice!

LINX-8 G8 Chains & Components

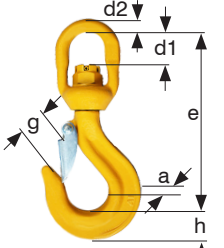
SLH Eye swivel hook with latch (bushed). (BS EN 1677-1+2)	Code	WLL	e	h	a	d1	d2	g	Weight
		[tonnes]	[mm]	[mm]	[mm]	[mm]	[mm]	[mm]	[kg/pc.]
	SLH7-8	2.00	153	23.5	21	29	13.5	27	0.85
	SLH10	3.15	188	29.5	22.5	34	15.5	32	1.55
	SLH13	5.30	235	38	33	41	18.5	40	3.31
	SLH16	8.00	278	45.5	39	53	21.5	45	5.33

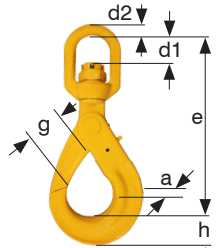
SVH Eye swivel safety hook (bushed) (BS EN 1677-1+3)	Code	WLL	e	h	a	w	d1	d2	g	Weight
		[tonnes]	[mm]	[mm]	[mm]	[mm]	[mm]	[mm]	[mm]	[kg/pc.]
	SVH6	1.12	164	20	18	32.5	23	11.5	27	0.70
	SVH7-8	2.00	186	26	19.5	36	28	13	35	1.11
	SVH10	3.15	222	30	26	42	35	15.5	44	1.91
	SVH13	5.30	266	40.5	33	50	40	17	53	3.65
	SVH16	8.00	328	50.5	43	61	56	21.5	60	7.27
	SVH20	12.50	365	55	50	70	60	26	77	10.35
	SVH22	15.00	460	68	53	97	96	33	80	17.9

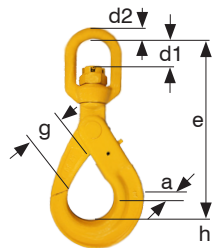
SVHB Eye swivel safety hook with ball bearing (BS EN 1677-1+3)	Code	WLL	e	h	a	w	d1	d2	g	Weight
		[tonnes]	[mm]	[mm]	[mm]	[mm]	[mm]	[mm]	[mm]	[kg/pc.]
	SVHB6	1.12	164	20	18	32.5	34	11.5	27	0.70
	SVHB7-8	2.00	195	26	19.5	36	40	13	35	1.11
	SVHB10	3.15	237	30	26	42	48	15.5	44	1.91
	SVHB13	5.30	282	40.5	33	50	58	17	53	3.65
	SVHB16	8.00	341	50.5	43	61	61	21.5	60	7.27
	SVHB20	12.50	399	55	50	76	75	26.5	77	10.35
	SVHB22	15.00	461	68	53	97	97	33	80	17.9
	SVHB26	21.20	536	75	60	123	115	42	98	21.5

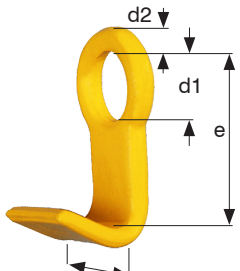
BH1T Barrel lifting hook (use in pairs) (BS EN 1677-1)	Code	WLL	e	d1	d2	b	Weight
		[tonnes]	[mm]	[mm]	[mm]	[mm]	[kg/pc.]
	BH1T	1.00	94	38	14	60	0.55

Please note that all dimensions stated are nominal and subject to change without prior notice!

LINX-8 G8 Chains & Components

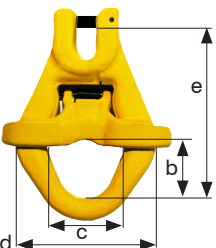
SHK Clevis skip hook with spring gate (BS EN 1677-1+2)	Code	WLL	e	b	c	d	Weight
		[tonnes]	[mm]	[mm]	[mm]	[mm]	[kg/pc.]
	SHK13	5.30	145	52	70	125	1.85
	SKT13	Forged safety latch kit complete for SHK13 skip hook					

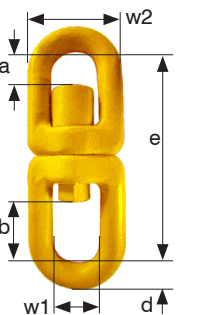
LDS Double eye swivel with ball bearing (BS EN 1677-1)	Code	WLL	e	w1	w2	d	a	b	Weight
		[tonnes]	[mm]	[mm]	[mm]	[mm]	[mm]	[mm]	[kg/pc.]
	LDS10	3.15	170	38	76	19	34	51	1.85
	LDS13	5.3	255	60	116	28	60	77	5.50

**NEW
for
2020**

Available from mid 2020

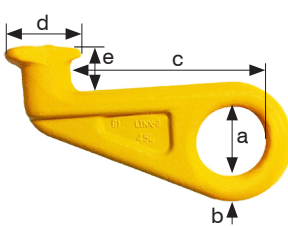
CLL45 Container lifting lug (BS EN 1677-1)	Code	WLL	a	b	c	d	e	Weight
		[tonnes]	[mm]	[mm]	[mm]	[mm]	[mm]	[kg/pc.]
	CLL45LH	12.5	70	25	190	48	45	3.98
	CLL45RH	12.5	70	25	190	48	45	3.98

45° LEFT AND RIGHT HANDED CONTAINER LIFTING HOOKS.
 Always use with 2 x two leg chain slings along with a suitable spreader beam spanning the width of the container. See diagram below.
 Attach the lifting lugs to the container base lifting points only!
 Ensure that the correct handed lug is used and that it is properly inserted in to the lifting point.

Correct Lifting Practice For The Use Of LINX-8 Grade 8 CLL Container Lifting Lugs

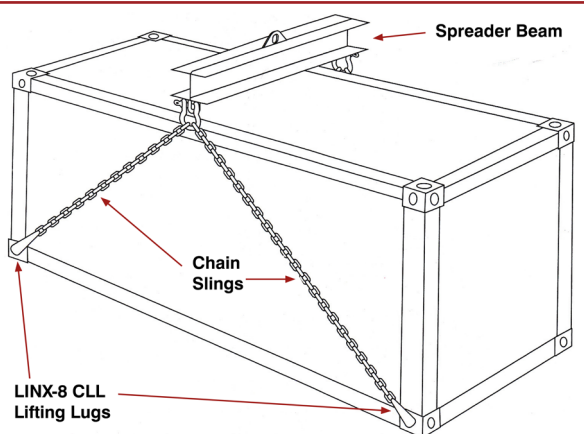

- Always use a spreader beam
- Always connect CLL lifting lugs to bottom lifting points on container
- Use with LINX-8 20mm chain (BCL20EN) and JL20 component connectors
- **WLL per set of 4 chains (as 2 x 2 legs):**
 34 tonnes (0-45° to vertical)
 25 tonnes (45-60° to vertical)



Please note that all dimensions stated are nominal and subject to change without prior notice!

LINX-8 G8 Chains & Components

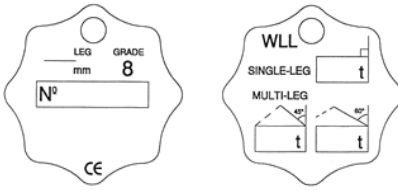
CRC Chain & wire rope connector	Code	Tensile force	For chain dia.	Saddle width (internal)	Plate angle	Weight
		[daN]	[mm]	[mm]		[kg/pc.]
	CRC7-8	4500	7 + 8	20	45°	0.65
	CRC10	7000	10	36	45°	1.20

ID Tag & Attachment Wire	Code	Application
	PLAINTAG G8	SINGLE & MULTI LEG G8 CHAIN SLINGS
	TAGWIRE	USE WITH ALL TAGS (SELF LOCKING)
	TAGLINK	USE WITH ALL TAGS

Please note that all dimensions stated are nominal and subject to change without prior notice!

Chain Load Lashing Systems For The Road Transport Industry

Load lashing or load restraint is a vital component for the safe transport of goods whether this be by road, rail or sea.

Outside forces applied to the load caused by the effects of braking, accelerating or cornering have a dramatic effect on how the load is to be restrained.

In a similar way to how we select lifting equipment, the shape and type of load as well as the effects of the working angles of the lashings, can increase the forces considered and consequently these factors affect the choice of both the type of lashing that should be selected and the method of how they should be used (friction or direct lashing).

BS EN 12195 Parts 1 to 4 were introduced to provide a means of conforming to the essential safety requirements for lashing and load restraint in the Common European market and thus enabling the free movement of goods.

Lashing equipment supplied by Brindley Chains is of high quality.

We are able to offer lashing chains and components in various grades, from our LINX-8 Grade 8 system, to Pewag Grade 10 which offers the user a 25% increase in lashing capacity for the same size chain over G8 (as the minimum requirement under the standard), to the new Pewag Grade 12 profiled chain system (for further details please refer to the sales brochures for these systems).

Whatever Brindley chain system you choose, it will meet or exceed the British and European standards.

This brochure contains all the information necessary to select the correct type and grade of equipment to suit your specific requirements. Whether you require direct or friction lashings, this guide will assist you in making an informed decision for selecting and specifying all manner of chain lashing equipment. With the aid of pre-calculated selection charts you will be able to choose the correct chain size and number of lashings to safely restrain the load.

Further details of chains, components, lashing points and other ancillary equipment can also be found within the brochure as well as details of certification and maintenance criteria and other services offered by us to the transport industry.

Common Materials With Dynamic Friction Factors Of $0.3\mu D$

- Aluminium against sawn wood
- Steel sheets against sawn wood
- Cardboard against wooden pallet
- Large bags against wooden pallet
- Flat steel bars against sawn wood
- Unpainted rough steel against sawn wood
- Unpainted rough steel against unpainted rough steel
- Rubber tyre against sawn wood
- Rubber tyre against rough steel

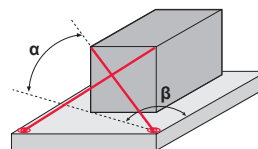

Example of direct lashing

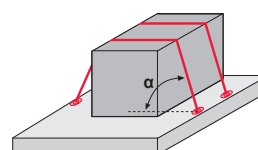

Example of friction lashing

For full details refer to BS EN 12195.

Direct Lashing Load Table

For materials with dynamic friction factors of 0.3 μ D with capacities based on FOUR equally loaded lashing chains

Working Angles		Lashing Size = 8mm			Lashing Size = 10mm			Lashing Size = 13mm		
α	β	Grade 8 LC = 40kN	Grade 10 LC = 50kN	Grade 12 LC = 60kN	Grade 8 LC = 63kN	Grade 10 LC = 80kN	Grade 12 LC = 100kN	Grade 8 LC = 100kN	Grade 10 LC = 134kN	Grade 12 LC = 160kN
20 to 35	21 - 30	11.65t	14.55t	17.45t	18.35t	23.30t	29.15t	29.15t	39.05t	46.65t
	31 - 40	10.50t	13.15t	15.75t	16.55t	21.05t	26.30t	26.30t	35.25t	42.10t
	41 - 50	9.10t	11.40t	13.65t	14.35t	18.20t	22.80t	22.80t	30.55t	36.45t
	51 - 60	7.45t	9.35t	11.20t	11.80t	14.95t	18.70t	18.70t	25.10t	29.95t
36 to 50	21 - 30	10.10t	12.65t	15.20t	15.95t	20.25t	25.35t	25.35t	33.95t	40.55t
	31 - 40	9.20t	11.55t	13.85t	14.55t	18.45t	23.10t	23.10t	30.95t	36.95t
	41 - 50	8.10t	10.15t	12.20t	12.80t	16.25t	20.35t	20.35t	27.25t	32.55t
	51 - 60	6.85t	8.55t	10.30t	10.80t	13.70t	17.15t	17.15t	23.00t	27.45t

The above table provides guidance information on how to get the best use from your chosen lashing system.

The table shows the maximum load that can be secured for road transport in a direct lashing arrangement with the load capacity of four equally loaded assemblies (see diagram on page 12).

The table is formulated using a coefficient of dynamic friction of 0.3 μ D for the material on both the load and the bed of the vehicle and also the maximum forces which can occur in transit due to acceleration, braking and cornering (according to BS EN 12195-1 2010) have been taken in to account. Load figures are based upon a 50 daN (approx. 50kg) maximum hand force applied to the ratchet handle in accordance with BS EN 12195-1.

Using this table you can select the correct lashing system in both grade and chain diameter.

Friction Lashing Load Table

For materials with dynamic friction factors of 0.3 μ D with capacities based on EACH lashing chain assembly. (Minimum of 2 x lashing chains must be used). STF = standard tension force.

Working Angles α	Chain size 8mm diameter - G8	Chain size 8mm diameter - G10	Chain size 10mm diameter - G8	Chain size 10mm diameter - G10	Chain size 13mm diameter - G8	Chain size 13mm diameter - G10
	G8 STF value 1000 daN	G10 STF value 1900 daN	G8 STF value 1574 daN	G10 STF value 3000 daN	G8 STF value 1500 daN	G10 STF value 2500 daN
90°	900 kg	1710 kg	1420 kg	2700 kg	1350 kg	2250 kg
85°	895 kg	1700 kg	1410 kg	2680 kg	1340 kg	2240 kg
80°	885 kg	1680 kg	1395 kg	2650 kg	1325 kg	2210 kg
70°	840 kg	1600 kg	1330 kg	2530 kg	1265 kg	2110 kg
60°	780 kg	1480 kg	1225 kg	2330 kg	1160 kg	1940 kg
50°	685 kg	1300 kg	1085 kg	2060 kg	1030 kg	1720 kg
40°	575 kg	1090 kg	910 kg	1730 kg	865 kg	1440 kg
30°	450 kg	850 kg	710 kg	1350 kg	670 kg	1120 kg

The above table provides guidance information on how to get the best use from your chosen lashing system.

The table shows the maximum load that can be secured for road transport in a friction lashing arrangement with the load capacity for EACH assembly. Important note: a minimum of 2 x lashings must be applied per load (see diagram on page 4).

The table is formulated using a coefficient of dynamic friction of 0.3 μ D for the material on both the load and the bed of the vehicle and also the maximum forces which can occur in transit due to acceleration, braking and cornering (according to BS EN 12195-1 2010) have been taken in to account. Load figures are based upon a 50 daN (approx. 50kg) maximum hand force applied to the ratchet handle in accordance with BS EN 12195-1.

Using this table you can select the correct lashing system in both grade and chain diameter and by a simple process of knowing the load weight divided by each lashing chain capacity value, you can determine the number of lashing assemblies required to secure the load.

LINX-8 G8 Load Lashing Systems

Single Part Chain Lashing Assembly

LDLS

In accordance with EN 12195-3
(Basic length 3.5 metres)



Code	Lashing capacity kN	Ratchet length		Tensioning range mm	Hook jaw opening mm
		(closed) mm	(open) mm		
LDLS8ENG8/3.5	40	575	770	195	24
LDLS10ENG8/3.5	63	610	785	175	28
LDLS13ENG8/3.5	100	710	850	140	34.5
LDLS16ENG8/3.5	160	730	900	170	43

Two Part Chain Lashing Assembly

LLS

In accordance with EN 12195-3
(Basic length 3.5 metres)

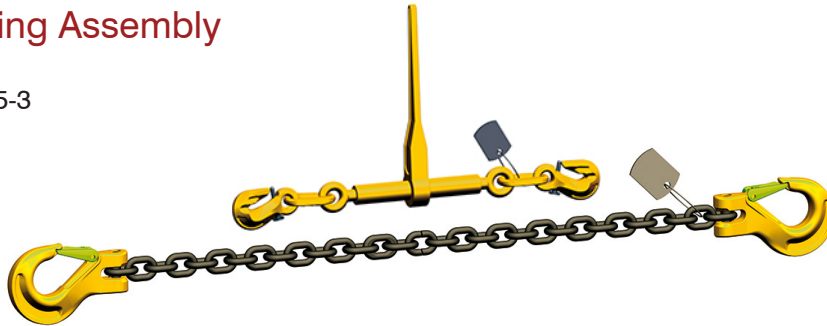

Code	Lashing capacity kN	Ratchet length		Tensioning range mm	Hook jaw opening mm
		(closed) mm	(open) mm		
LLS8ENG8/3.5	40	575	770	195	24
LLS10ENG8/3.5	63	610	785	175	28
LLS13ENG8/3.5	100	710	850	140	34.5
LLS16ENG8/3.5	160	730	900	170	43

LINX-8 G8 Ratchet Loadbinders

RLB / RLB/T (with tag) Ratchet load binder (BS EN 12195)	Code	Lashing capacity	Length closed	Length open	Tension range	Weight
		[kN]	L [mm]	L [mm]	[mm]	[kg/pc.]
	RLB8	40	575	770	195	4.50
	RLB10	63	610	785	175	5.00
	RLB13	100	710	850	140	7.50
	RLB16	160	730	900	170	9.87
	RLB8/T	40	575	770	195	4.50
	RLB10/T	63	610	785	175	5.00
	RLB13/T	100	710	850	140	7.50
	RLB16/T	160	730	900	170	9.87

LINX-8 G8 Lashing Accessories

ID Tag & Attachment Wire	Code	application
	LASHTAG	Load lashing assemblies (any grade)
	TAGWIRE	Use with tag

RLB...PIN Safety pin set for RLB ratchet loadbinder	Code	For hook size
	RLB8PIN	8
	RLB10PIN	10
	RLB13PIN	13
	RLB16PIN	16

LINX-8 G8 Spare Parts

LP Clevis load pin & retaining pin set	Code	For component size
		[mm]
	LPA6 / LPB6 / LPD6	6
	LPA7-8 / LPB7-8 / LPC7-8 / LPC7-8 / LPD7-8 / LPE7-8 / LPF7-8	7 + 8
	LPA10 / LPB10 / LPC10 / LPD10 / LPE10 / LPF10 / LPG10	10
	LPA13 / LPB13 / LPC13 / LPD13 / LPE13 / LPF13 / LPG13	13
	LPA16 / LPB16 / LPC16 / LPD16 / LPE16 / LPF16	16
	LPA20 / LPB20	20
	LPA22 / LPB22	22
	LPA26 / LPB26	26
	LPA32 / LPB32	32

Key: LPA = ASH Sling hook, LPB = ALH Safety hook, LPC = ACH C-hook, LPD = AGH Grab hook, LPE = ARL Reeving link, LPF = ACS Clevis shackle, LPG = ALS Safety hook

JPB Load pin and retaining sleeve for JL component connector	Code	For connector size
		[mm]
	JPB6	6
	JPB7-8	7 + 8
	JPB10	10
	JPB13	13
	JPB16	16
	JPB20	20
	JPB22	22
	JPB26	26
	JPB32	32

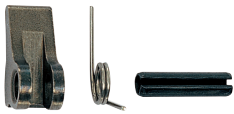
LTS Trigger set for ALH, ALS, BLH and SVH safety hooks	Code	For hook size
 <p>* LTC for ALS compact safety hook</p>	LTS6	6
	LTS7-8	7 + 8
	LTS10 / LTC10*	10
	LTS13 / LTC13*	13
	LTS16	16
	LTS20	20
	LTS22	22
	LTS26	26
	LTS32	32

SCS Forged safety catch set for ASH and BSH sling hooks	Code	For hook size
	SCS6	6
	SCS7-8	7 + 8
	SCS10	10
	SCS13	13
	SCS16	16
	SCS20	20
	SCS22	22
	SCS26	26
	SCS32	32

SHC Safety catch set for SLH swivel hook	Code	For hook size
	SHC7-8	7 + 8
	SHC10	10
	SHC13	13
	SHC16	16

Information for use, storage and maintenance of LINX-8 Grade 8 chain slings in accordance with the Machinery Directive 2006/42/EC

General

LINX-8 Grade 8 lifting slings and accessories can be used for general lifting purposes covering a wide range of designs, loads and slings. Detailed information of all chain, components and chain slings are given in this catalogue and follows the 'Uniform Load Method of Rating' as standard.

Chain slings should be used only by trained personnel.

If properly used, LINX-8 chain slings offer a long service life with a high degree of safety. Improper use could result in personal injury and damage to property. It is therefore highly important that you read and understand this user information and act in a responsible and forward thinking manner when using any kind of lifting equipment.

Limitations of use

To modify or to repair a LINX-8 mechanically joined chain sling it should be returned to Brindley Chains Ltd or one of our agents for assessment and repair, and only genuine LINX-8 parts should be used.

The shape of the sling must not be modified e.g. by bending, grinding, welding, drilling, or separation of individual parts. Avoid heating of the chains to more than 380°C or use at temperatures below -40°C.

Do not remove any safety components, such as safety catches, safety pins etc.

Do not apply any surface coating to the chain slings, i.e. do not subject them to hot galvanizing or electro galvanizing.

If in doubt, please contact our technical department who will be pleased to provide further information.

Restrictions of use due to hazardous or dangerous conditions should be assessed using the table on page 4.

Temperature

The reduction of load capacity caused by high temperatures (see page 4) ceases once the chain or lifting component reaches room temperature. Lifting accessories should not be used outside the stated temperature range.

In the event of a sling being exposed to temperatures outside of this range, it should be withdrawn from service indefinitely.

Acids, caustics and chemicals

LINX-8 Grade 8 chain slings should not be used with chemicals or in corrosive atmospheres due to the danger of stress cracking (hydrogen embrittlement).

Certain production procedures can release acids and /or fumes which are detrimental to the sling material.

Working load limit

The working load limits stated on the EC Declaration Of Conformity supplied with all LINX-8 chain slings have been determined on the basis that the loading of the chain sling is symmetrical (multi leg slings) and that there are no particularly hazardous conditions. Such hazardous conditions could be offshore applications, the lifting of people and potentially dangerous loads, such as liquid metals, corrosive or caustic substances or nuclear material.

When a chain is used in choke hitch, i.e. with the sling leg passed around a load and hooked or linked back on to the chain, the working load (SWL) of the chain sling should be no more than 80% of that marked on the sling.

For Asymmetrical (unequally loaded multi leg slings) the lift should be referred back to a competent person to establish a safe rating.

Working load limit (continued)

Edge loadings – care should be taken when using chain slings around sharp corners as this will affect the working load (WLL) of the sling. If the sling is to be used for such purposes, the extent of the risk is to be assessed by an expert and the safe working load (SWL) should be adjusted accordingly.

Impact

The maximum load capacity (WLL) of LINX-8 chain slings is based on the assumption that the load on the individual chain legs is applied without any impact or shock loading. In the cases of possible impact/shock load, the load factors indicated, must be taken into account. See the table on page 4 for more details.

Examples:

- Slight impact: created, for example, when accelerating the lifting or lowering movement
- Medium impact: created for example, when the chain slips when adjusting to the shape of the load
- Strong impact: created for example, when the load falls into the unloaded chain

Inspections and tests

Before using any item of lifting equipment for the first time, it should be ensured that:

- The chain sling corresponds exactly to the order and that the inspection certificate or certificate of conformity has been supplied.
- Marking and capacity on the chain sling corresponds to the information given on the inspection certificate or certificate of conformity.
- All particulars of the chain sling must be entered into the register of lifting equipment.
- Instructions for the proper use of chain slings have been supplied, read and understood by personnel.

Before each use

Check the chains before each use for visible signs of damage or wear. If in any doubt, do not use the chains and have them inspected by a competent person.

Periodic thorough examination

It is recommended that the period of this examination be as per the requirements of Lifting Operations and Lifting Equipment Regulations 1998 (LOLER) or as part of an agreed written plan agreed between a competent person and the owner of the equipment.

Elimination criteria following visual inspection

- Any broken or damaged parts.
- Missing or illegible marking of the chain sling, i.e. identification data and /or load capacity data.
- Deformation of suspension master links or sling parts or the chain itself.
- Elongation of the chain; The chain must be discarded if (t) (nominal pitch i.e. inside length of the chain link) $\geq 1.05t_n$ (+5%), and master links and joining links (+10%).
- Wear - Chain wear is determined as the mean of two measurements of diameters d1 and d2 carried out at a right angle at the crown of the link. When compared to the nominal diameter of the chain when new.

$$\frac{d1 + d2}{2} \leq 0.9d_m \text{ (-10\%)}$$

- Master links and joining links (-15%)
- Cuts, notches, grooves, surface cracks, excessive corrosion, discoloration due to heat, signs of subsequent welding process, bent or twisted links or other flaws.
- Cracks: Chains with cross cracks that are visible to the naked eye must be discarded.
- Missing or non-functioning safety devices (safety catches) if fitted, as well as signs of widening or twisting of master rings, hooks i.e. noticeable enlargement of the opening must not exceed 10% of the nominal value.

Repair

Linx-8 lifting accessories and slings should only be repaired by qualified personnel, using only genuine LINX-8 replacement parts.

Documentation Records of inspections, and in particular their findings, as well as details of repairs carried out must be kept on file during the entire service life of the chain sling.

Storage

Where possible LINX-8 chain slings should be stored in a cleaned and dry condition and protected from corrosion.

Chain Sling Builder App

The Chain Sling Builder App has been developed to assist riggers in determining the most suitable chain sling configuration for a given lifting application.

The App provides final build options for the most commonly used grades of chain including G8, G10 and G12 and allows the user to select specific leg terminations and shortener options.

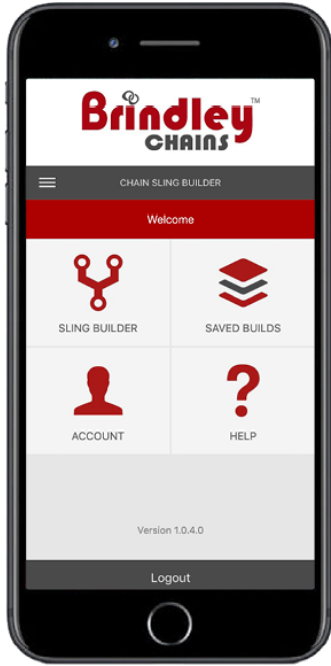

Chain Sling Builder App.

FREE and available now for iOS and Android.



Screen Shots

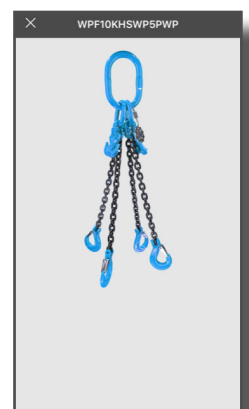
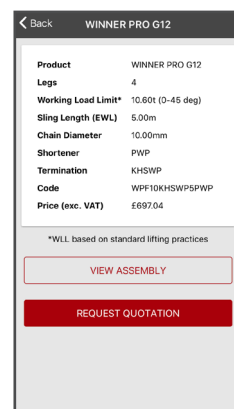
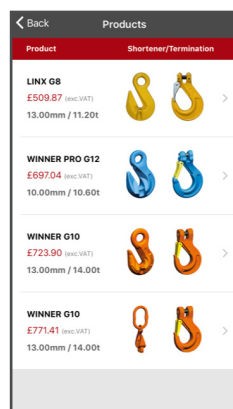
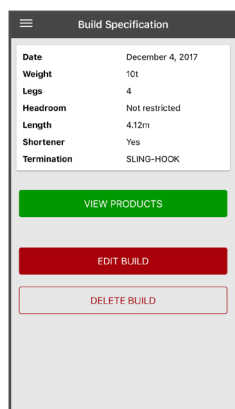
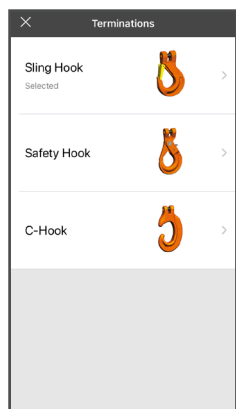
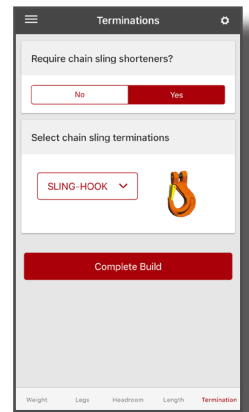
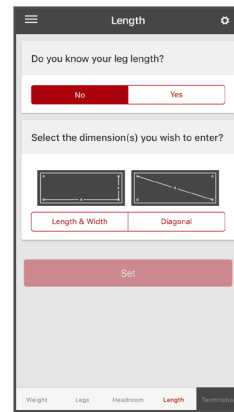
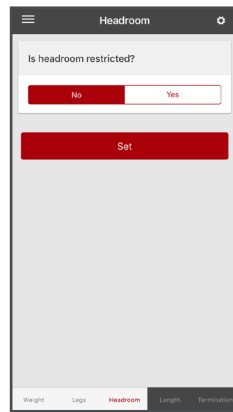
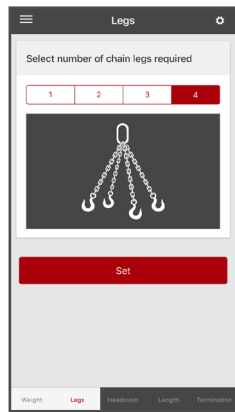
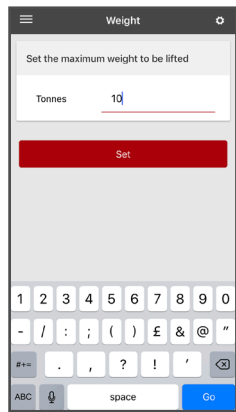



Brindley Chains was first awarded certification to ISO 9000 quality management system back in 1996, and in 2017 the company was certified to the very latest version of the standard, ISO 9001:2015.

The company has been an active member of the Lifting Equipment Engineers Association (formerly named the Chain Testers Association of Great Britain) since 1986 and has sat on the technical committee throughout the duration of this membership.





www.brindleychains.co.uk