



User Guide

MS1000

Money Scale



www.AccuBANKER.com

**Thank you for trusting *AccuBANKER*
with your cash handling needs.**

**In order to optimize the performance of your
equipment, we encourage you to thoroughly read
this user guide prior to use.**

www.AccuBANKER.com



Table of Contents

Introduction	4
Box Contents	5
1. Safety Instructions	6
2. Equipment Overview	8
3. Getting Started	9
4. Control Panel Description	11
5. Calibration Adjustment	13
5.1 Weight Calibration	13
5.2 Coin Tray Weight Calibration	14
6. Configuration Menu	15
6.1 Set Preferences	15
7. Operation	19
7.1 Counting Operation	19
7.2 Deleting Partial Result of a Count	22
7.3 Deleting All Counts	22
7.4 Reviewing the Details of a Count	22
7.5 Printing Results of a Count	22
8. Troubleshooting and Maintenance	23
8.1 Counting Errors Solution	23
8.2 Cleaning and Maintenance	23
9. Software Updates	24
10. Specifications	25

Introduction

This innovative device uses the most modern technology for counting both coins and bills. Built with high-performance sensors and a sophisticated algorithm, this money scale helps determine the number of coins and bills instantly. These features make the MS1000 the most effective solution for cash handling by combining various types of counting in a single device.

Box Contents

1. MS1000 Unit
2. Money Platform
3. Coin Tray
4. Power Adaptor
5. Warranty Booklet
6. User Guide
7. 500g Calibration Weight
8. Lithium Battery

1.

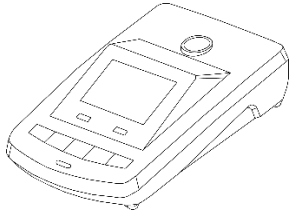

2.

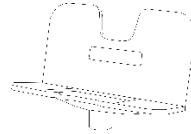

3.

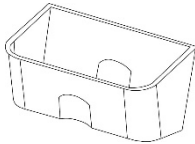

4.

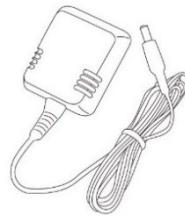

5.

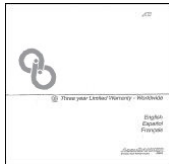

6.

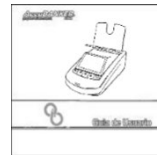

7.



8.



1. Safety Instructions



Warning

	Do not use this product in areas where it may be exposed to water or other liquids.
	Unplug this product from the electric outlet before cleaning. Do not use liquid or aerosol cleaners. To clean, use a damp cloth, compressed air, or cleaning cards.
	To reduce the risk of electric shock, do not disassemble this product. Take it to qualified service personnel when service or repair work is required. Opening or removing covers may expose you to dangerous voltages or other risks. Incorrect reassembly can cause electric shock when the appliance is subsequently used.
	Only use the cable provided with the unit. The use of other cables may result in electric shock, fire, or cause serious damage to the unit.
	Do not operate the unit in areas with high temperature or high humidity since it may prevent it from working correctly.



Caution

	When unplugging the power cord, do not pull it by the cord, but rather grip the plug to pull it out.
	Do not use the unit if the power cord is damaged or if the plug socket contact is loose.
	Do not place heavy objects over the cord and do not bend it excessively since it could get damaged.
	When not using the unit for a long time, remove the power plug from the electric outlet.

*Not following these instructions may result in electric shock, fire, damage to the unit, or other hazards.

1. Safety Instructions (continued)

- Follow all warnings and instructions marked on the user guide and/or on the unit.
- This product should be used indoors in a space with proper ventilation.
- Do not place in direct sunlight, heat sources, or air conditioners.
- This product should only be operated with the power cord supplied and the type of power source indicated on the equipment.
- To avoid the risk of fire or electric shock, never push objects into the unit through the case slots or openings, since they may touch dangerous voltage points or shortcut parts. Do not disassemble the unit.
- Never spill liquids of any kind on the product.
- Unplug this product from the wall outlet and defer servicing to qualified service personnel under the following conditions:
 - When the power supply cord or plug is damaged or frayed.*
 - If liquid is spilled into the unit, or it has been exposed to rain or water.*
 - If the product has been dropped or the case has been damaged.*
 - If the product shows a noticeable change in performance.

* Not covered under warranty

NOTE: Do not remove the "ground" prong from the power cord. It is a safety feature meant to protect the user from harm and the equipment from damage.



If the unit does not operate normally while following the instructions, adjust only those controls explained in the operating instructions. Improper adjustment of other controls may result in damage and could require extensive work by a qualified technician to restore the product to normal operation.

2. Equipment Overview

1. LCD
2. Money Platform
3. Control Panel (buttons)
4. Charge Indicator Light
5. Power Jack
6. USB Port for Software Updates
7. Serial Port for Printer
8. Battery Compartment

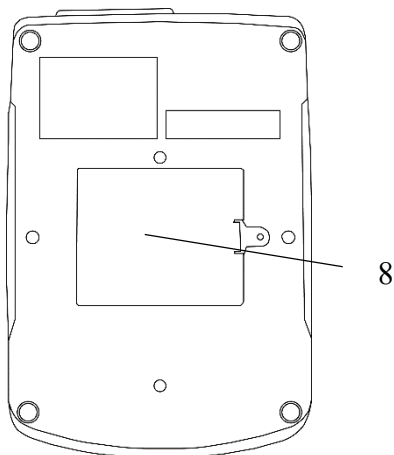
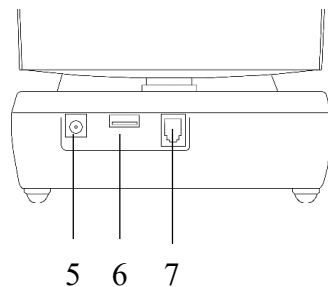
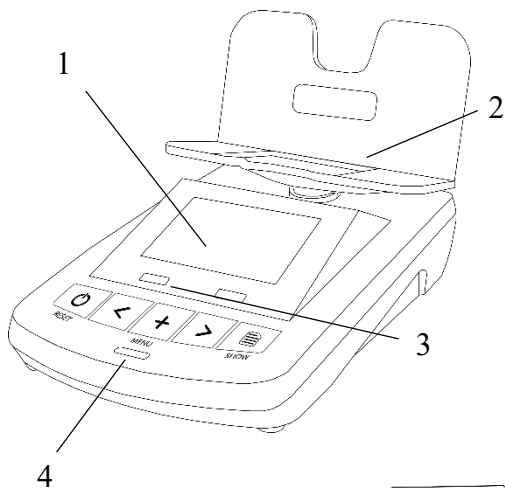

3. Getting Started

1. Remove the battery compartment cover. Connect the battery to the equipment using the connector, place the cable and battery correctly, and close the compartment.

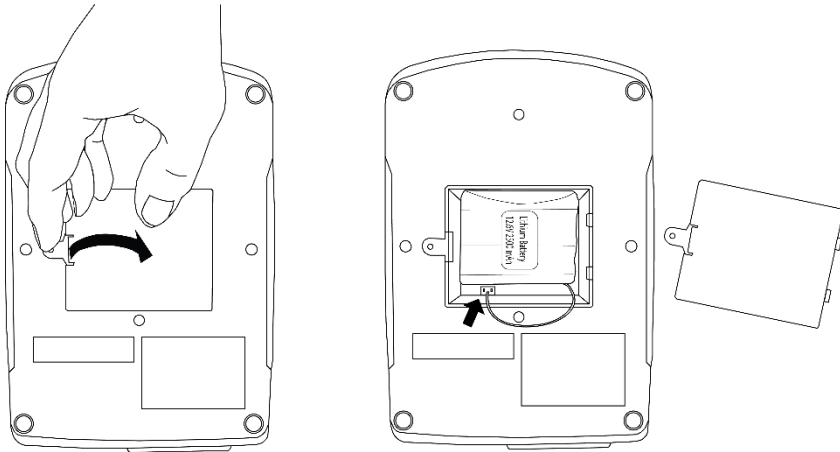

2. Install the money platform as the reference image shows.

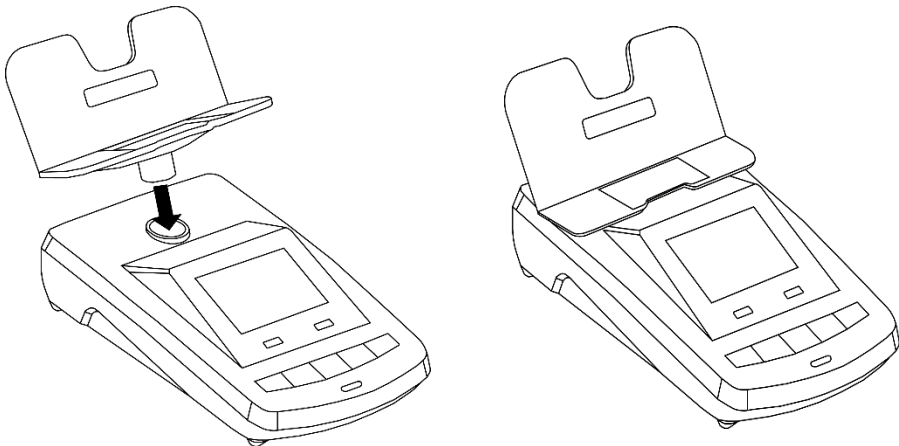

3. Getting Started (continued)

3. Connect the equipment to the power adaptor and plug it into a wall outlet as the reference image shows.

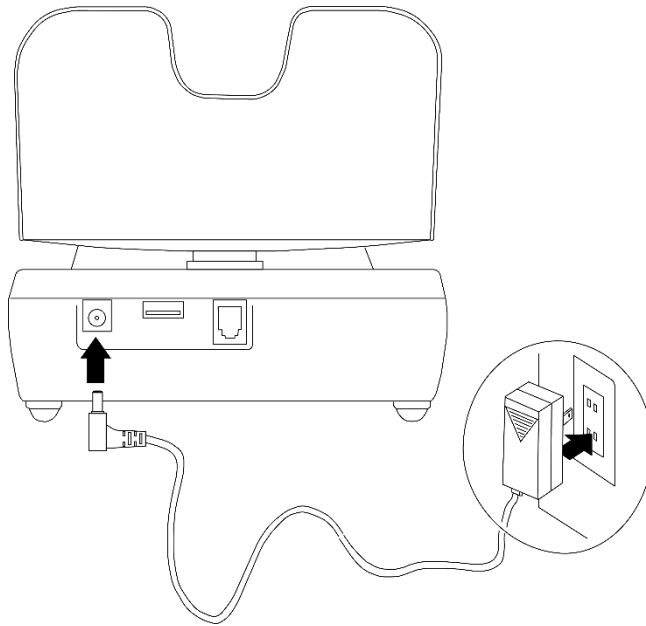

Important!

Do not use the unit if the power adaptor or electric outlet is damaged. Not following these instructions may result in electric shock or other hazards.

When unplugging the power adaptor, do not pull it by the cord, but rather grip the plug to pull it out. Not following these instructions may result in electric shock or damage to the unit.

Remove the power plug from the electric outlet if it will not be used for a long period of time.

4. Control Panel Description

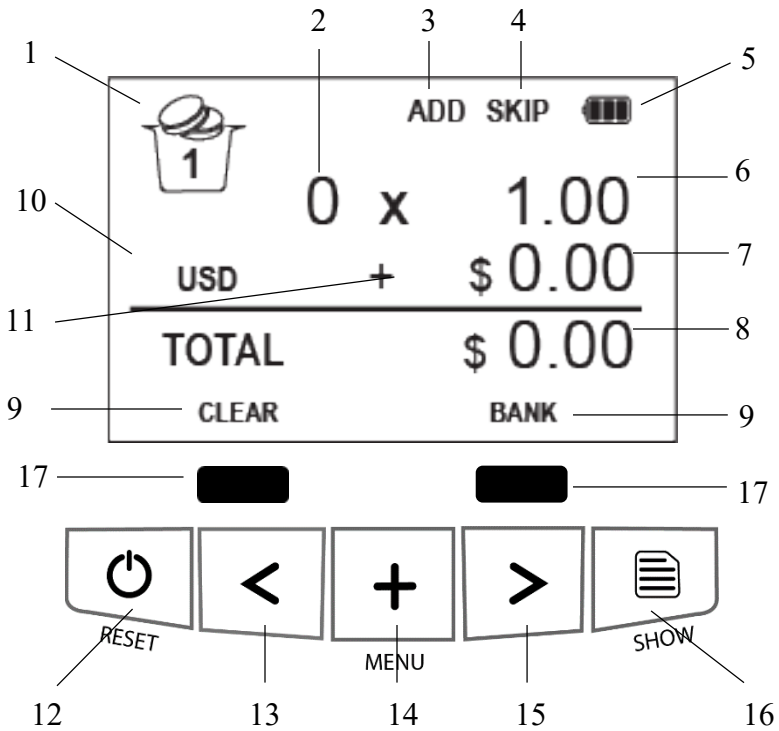

1. Indicates the active counting mode and denomination.



a) Loose coins mode

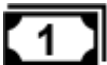

b) Loose bills mode



c) Coin rolls mode



d) Strapped bills mode



e) Coin bag mode

4. Control Panel Description (continued)

2. Indicates the number of pieces counted.
3. Indicates if the ADD function is activated.
4. Indicates if the automatic denomination change mode is activated.
5. Indicates the current battery level.

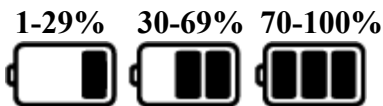

6. Indicates the value of the current denomination selected to count.
7. Indicates the partial value of the counted denomination.
8. Indicates the total value of all the counted denominations.
9. Active floating function.
10. Indicates the type of currency to count.
11. Indicates when the partial value is added to the total accumulated value of all counted denominations.
12. Button for turning on/off the unit and restarting the total count (RESET).
13. Left selector button.
14. Menu access button or manual Addition mode function (ADD) of the counted bills.
15. Right selector button.
16. Print button or to show the detailed breakdown of the active count.
17. Floating functions button.

5. Calibration Adjustment

5.1 Weight Calibration

Before starting to count for the first time, the equipment must be calibrated. Make sure you have the money platform installed before proceeding.

(3. Getting Started)

1. Turn on the device by pressing the power button for 2 seconds.
2. Press OK to confirm the platform is installed and empty.
3. Enter the setup menu by pressing the **MENU** button for 3 seconds.
4. Select “Calibration” and press SET to enter calibration mode, then select “Weight Calibration”, press SET, and carefully follow the steps on the screen:
 - a. Remove everything from the platform and then press “OK”.
 - b. Wait until the sensor adjusts to ZERO.
 - c. Place the 500g calibration weight on top of the platform as shown in the picture and press “OK”
 - d. The sensor will start the calibration with the 500g weight, please wait for it to finish.
 - e. When calibrated effectively, a confirmation will appear on the screen. Then you can remove the 500g calibration weight.

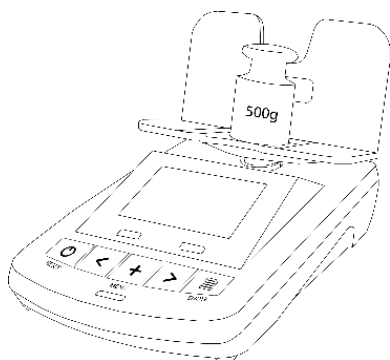

Note: If you find any type of error during the counting process, you can perform this calibration at any time. Follow the same steps mentioned previously to proceed with the calibration.

5. Calibration Adjustment (continued)

5.2 Coin Tray Weight Calibration

To count loose coins, you should use the coin tray included with the equipment, or you can also choose your container for coins like the one that comes with your cash register.

Coin Tray Setup: Enter this setting to set your preferred container weight. Place the empty container on the platform and then press the “SAVE” button to save the weight.

Important!

- You should always use the configured container when counting loose or rolled coins.
- Do not use the coin tray when counting in another mode, such as loose bills, strapped bills, or coin bags.
 - a. Coin tray included with the MS1000.
 - b. Example of another container or tray to use with the MS1000.

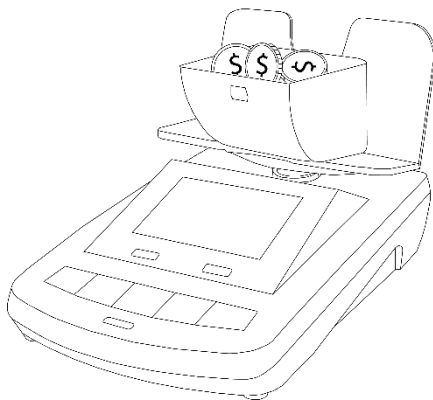
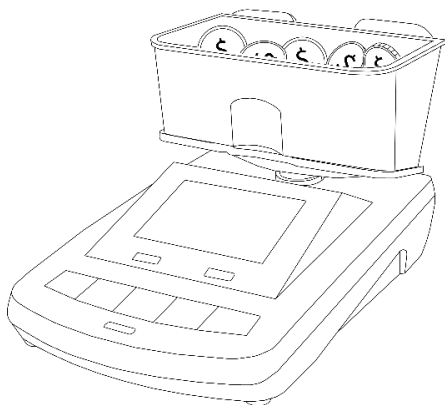

6. Configuration Menu

6.1 Set Preferences

Before starting to work, it is recommended that you configure your equipment according to some of your needs or preferences.

Enter the Menu to set up the functions. Move the selector over the function to configure, using the selector buttons “<” or “>” and press “SET” to enter the desired setting. Press “BACK” to exit to the main menu.

1. **Modes Setup:** Enter this setting to select some preferences.
 - a. **Auto Skip:** Activate this function to automatically move the count to the next denomination to count. If this option is disabled, you must press the selector button “>” to go to the next denomination.
 - b. **Auto ADD:** When you activate this function, the total pieces and the total value will automatically be added to the general count. If the function is deactivated, the “+” button must be pressed to add the total number of pieces counted and the total value to the general count.
 - c. **Standby Mode:** Select if you want to set the timer for sleep mode. By configuring this mode, the equipment will turn off after reaching the selected time of inactivity.
 - d. **Strapped Bills:** To activate/deactivate the counts in the strapped bills mode.
 - e. **Rolled Coins:** To activate/deactivate the counts in the rolled coins mode.
 - f. **Bags:** To activate/deactivate the counts in the coin bags mode.

6. Configuration Menu (continued)

6.1 Set Preferences (continued)

2. **Other Items:** In addition to counting bills and coins, this equipment can be configured to count other items such as tokens, cards, or other small items as long as each of the items have the same weight. To proceed, select the item you want to calibrate to count and group 20 pieces of the same item.

a. **Setup New Item:** Enter this setting to set the weight of the new item to count. You will only be able to configure three new items, Token, Card, or Custom Item. Select one of these, place 20 pieces of the same item on the platform, and press “SAVE” to save the setting.

b. **Count Other Items:** Select the type of item to be counted and place them directly on the platform.

c. **Weight Scale:** Use the scale to weigh any item as long as it does not exceed the maximum weight of 4.4lb (2kg).

Important! When setting up or counting the items, they must all share the same weight for an accurate count. The items will be counted according to the specific weight of each one.

3. **Bank Wizard:** You will be able to deduct from your counts the opening cash register amount that you started with before your first transaction of the day.

a. **Bank Setup:** Select this function to set the opening balance amount that is in the register at the time of counting. Enter the value using the “<” or “>” buttons to increase or decrease the value in multiples of 5, press the floating button to increase the value by +1. As soon as you get the desired value, press “SAVE” to save the value.

Note: You may modify this value at any time.

6. Configuration Menu (continued)

6.1 Set Preferences (continued)

- b. **Apply Bank:** You can activate the function for all counts by default by activating the function from this menu, or at the time of the count by activating the “BANK”.
4. **Calibration:**
 - a. **Weight Calibration:** Follow the instructions in section 5.1 (**Weight Calibration**) to correctly calibrate this equipment.
 - b. **Coin Tray Setup:** Follow the instructions in section 5.2 (**Coin Tray Weight Calibration**) to correctly calibrate this equipment.
 5. **Date & Time:** Enter and save the date and time to record them when printing reports of the counts.
 - a. Use the selector “<” or “>” to move through the options.
 - b. Use the floating buttons “UP” and/or “DOWN” to increase or decrease the value.
 - c. When you finish setting the day and time, move the cursor to “NEXT” and press “SAVE” to save the setting.
 6. **Denomination Options:** Activate or deactivate some denominations of bills and coins that are rarely used. If certain denominations do not need to be in the counts, you can deactivate them to speed up the counting process.
 7. **Currency:** Use to select the currency to be counted. This equipment is factory configured for USD.

6. Configuration Menu (continued)

6.1 Set Preferences (continued)

8. **Sound:** Enable or disable the sound alert type for the menu options.
 - a. **Warning:** Alerts any type of error.
 - b. **Notification:** Alerts some completed functions, such as count, added to the total, and other actions.
 - c. **Keyboard:** Beeps each time any button is pressed.
9. **Restore Factory Settings:** Use this function to reset the settings to factory parameters. Enter this setting and press the “OK” button to begin the operation.

Important! After starting the configuration adjustment, you will not be able to access the custom settings.
10. **About:** Enter into this section to check the software version installed on the device.

7. Operation

7.1 Counting Operation

Cash counting starts with the loose coin counting mode, starting from the smallest denomination to the largest. Always keep the following in mind:

- a. Separate coins and bills by denomination.
- b. Select the correct counting mode and denomination before placing them on the platform.
- c. Never exceed the maximum capacity of the tray when placing money or the maximum weight of 4.4lb (2kg).
- d. After placing the money on the platform, an alert sound (beep) will notify you that the amount has been registered. If the ADD function is activated, it will automatically add the amount to the total count. If it is not activated, press the + button to manually add the quantity to the total.
- e. When you remove the money, the counting mode will automatically move to the next denomination if the SKIP mode is activated. If the SKIP mode is not activated, press the “<” or “>” button to change it manually.

Important! There are two versions of the penny (1¢ USD) coins in circulation, with different weights. Please note that if these two versions are mixed, you may experience problems with the count result. This issue only applies to this coin and cannot be resolved with calibration or other adjustments.

7. Operation (continued)

7.1 Counting Operation (continued)

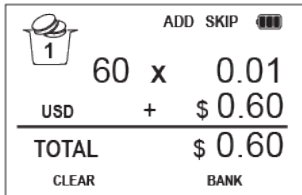

1. Counting loose coins:

Before putting the coins on the platform, put them in the tray, set for coins. Once counted, remove the tray, take out the coins, and repeat the process until the count is complete.

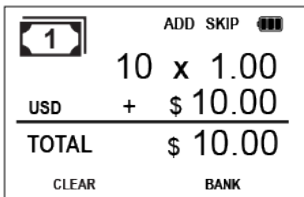

2. Counting loose bills:

Place loose bills directly on the platform. Do not put groups of more than 25 bills at a time. Place groups of bills continuously without removing them until the count of the same denomination is complete. When finished, remove them all at once. Avoid counting:

- Stapled bills
- Bills stuck with adhesive tape
- Ripped bills
- Wet bills

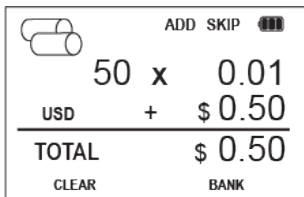

3. Counting rolled coins:

Always use the coin tray to count rolled coins. Place the tray on the platform with only one whole coin roll and continue putting the rest of the packages one at a time. You will be able to mix rolls of various denominations. Upon completing the count, you will need to remove the tray with all the rolled coins at once to save the count.

7. Operation (continued)

7.1 Counting Operation (continued)

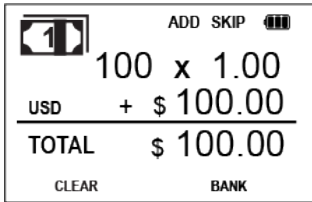

4. Counting strapped bills:

Place strapped bills of the same denomination directly on the platform. Add one bundle at a time without removing prior bundles until completed. At the end of the count, remove all bill bundles, at the same time, to add them to the total count.

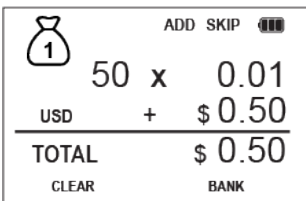

5. Counting coin bags:

Place the coins bags of the same denomination directly on the platform. Always use small plastic bags. Never exceed the capacity of the platform.

Important! The total number of coins must not exceed 200 pieces or the total weight of 4.4lb (2kg).

6. BANK application:

Some cashier closings require deducting the opening balance for a new shift. To activate the “BANK” function at any time during the count, press the “BANK” button. This will deduct the opening balance from the total count amount. The “BANK” value must be previously configured in the “Bank Wizard” configuration menu. To deactivate “BANK” press the “CANCEL” at any time during counting.

Example for a BANK of \$200:

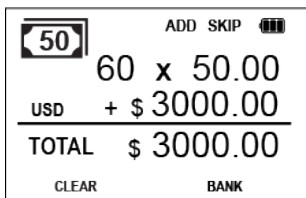

BANK NOT APPLIED

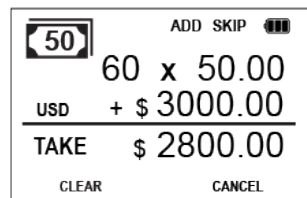

BANK APPLIED

7. Operation (continued)

7.2 Deleting Partial Result of a Count

To clear the count for a specific denomination at any time, select the denomination to be cleared and press “CLEAR”. This will remove the count for the specified denomination, but it will not remove the count for another denomination.

7.3 Deleting All Counts

After you complete your counts, you can reset them to 0 to start a new count. Press the “RESET” button to clear all counts.

Important! Keep in mind that when you delete the counts, you will not be able to view, print, or retrieve the deleted count.

7.4 Reviewing the Details of a Count

Press the “SHOW” button to access the detailed report of all coins and bills counted. Change the report from coins to bills by pressing the “<” and “>” buttons.

Coins			
0.01 x	10	\$	0.10
0.05 x	10	\$	0.50
0.10 x	100	\$	10.00
0.25 x	50	\$	12.10
1.00 x	10	\$	10.00
<hr/>			
TOTAL		\$	32.70
PRINT		EXIT	

Bills			
1 x	10	\$	10.00
5 x	10	\$	50.00
10 x	100	\$	1000.00
20 x	50	\$	1000.00
50 x	10	\$	500.00
100 x	10	\$	1000.00
<hr/>			
TOTAL		\$	3560.00
PRINT		EXIT	

7.5 Printing Results of a Count

The counter can be connected to the MP20 receipt printer to print the detailed report of your counts. (Printer sold separately).

8. Troubleshooting and Maintenance

8.1 Counting Errors Solution

If you find any errors in the count, such as an inaccurate count resulting in a higher or lower amount of bills or coins that were placed to be counted, check that you are placing the money on the platform correctly, as explained in section 7 (**Operation**). If the error persists, make sure that the counter calibration is correct. Enter the MENU to access the calibration and follow the instructions as described in section 5 (**Calibration Adjustment**).

8.2 Cleaning and Maintenance

Clean the unit periodically to keep it in optimal condition. This way, you will ensure proper operation and extend its useful life.

Turn off the unit when not in use. Use a clean cloth or brush to remove any dust deposited on the counting platform area and on the unit.

9. Software Updates

AccuBANKER will provide any updates to the unit's software if required. To update the software, follow these steps:

1. Copy the updated version of the software onto a USB stick with a maximum capacity of 8GB.
2. With the counter turned off, insert the USB stick into the unit's port, located on the back of the unit.
3. Press the “**RESET**” and “<” buttons at the same time for 2 seconds to enter the software update mode.
4. The unit will recognize the new update and start the process automatically. When finished, the system will reboot.

10. Specifications

Ambient Temperature:	32° - 104°F 0° - 40°C
Ambient Humidity:	25% - 80%
Display:	LCD 3.5 in
Power Source (Vin):	100-240V AC 60-50 Hz 0.6A
Power Source (Vout):	13.8V DC/2.0 A
Power Consumption:	< 15W
Battery:	Rechargeable Lithium 12V 3.0A
Maximum Counting Capacity:	Up to 25 bills/second Up to 200 coins/second
Maximum Counting Weight:	4.40 lb 2.00 kg
Dimensions: (<i>L x W x H</i>)	8.8 x 5.9 x 5.5 in 22.5 x 15 x 14 cm
Weight:	1.90 lb 0.86 kg



AccuBANKER
7104 NW 50th St. Miami, FL 33166
9:00 am - 5:00 pm ET • Monday to Friday

www.AccuBANKER.com
Call us at 1-888-993-2228