



User Guide

D480

Automatic Trio  
Counterfeit Bill Detector



[www.AccuBANKER.com](http://www.AccuBANKER.com)

---

**Thank you for trusting *AccuBANKER*  
with your cash handling needs.**

**In order to optimize the performance of your  
equipment, we encourage you to thoroughly read  
this user guide prior to use.**

---

[www.AccuBANKER.com](http://www.AccuBANKER.com)



# Table of Contents

Table of Contents .....	3
Introduction .....	4
Box Contents .....	4
1. Safety Instructions .....	5
2. Equipment Overview .....	7
3. Control Panel Description .....	9
4. Operation .....	11
4.1 Basic Operation .....	11
4.2 Suspicious Bill Warning .....	12
4.3 Bill Positioning .....	13
5. Troubleshooting & Maintenance .....	14
5.1 Preventive Measures .....	14
5.2 Jamming .....	14
5.3 IR Sensor Calibration .....	15
5.4 Maintenance .....	16
5.5 Cleaning the Magnetic Heads .....	16
6. Software Updates .....	17
7. Specifications .....	18

# Introduction

The D480 incorporates the most sophisticated techniques for the evaluation and detection of counterfeit bills. The D480 allows the user to switch between three pre-programmed currencies to select the currency they are interested in verifying. This detector assesses the security features that are present on each bill in detail and determines if the bills are genuine or suspicious while automatically alerting the user, both visually and audibly, in under one second.

## Box Contents

1. D480
2. Power Adapter
3. User Guide
4. Warranty Booklet

1.

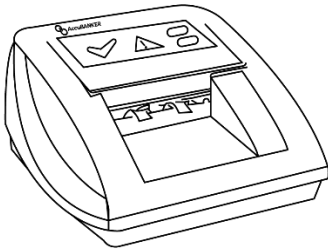

2.



3.

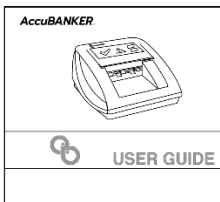



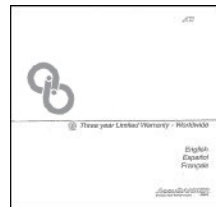

4.







# 1. Safety Instructions

## Warning

	Do not use this product in areas where it may be exposed to water or other liquids.
	Unplug this product from the electric outlet before cleaning. Do not use liquid or aerosol cleaners. To clean, use a damp cloth.
	To reduce the risk of electric shock, do not disassemble this product. Take it to qualified service personnel when service or repair work is required. Opening or removing covers may expose you to dangerous voltages or other risks. Incorrect reassembly can cause electric shock when the appliance is subsequently used.
	Only use the cable provided with the unit. The use of other cables may result in electric shock, fire, or cause serious damage to the unit.
	Do not operate the unit in areas with high temperature or high humidity since it may prevent it from working correctly.

## Caution

	When unplugging the power cord, do not pull it by the cord, but rather grip the plug to pull it out. Not following these instructions may result in electric shock, fire, or damage to the unit.
	Do not use the unit if the power cord is damaged or if the plug socket contact is loose. Not following these instructions may result in electric shock, fire, or other hazards.
	Do not place heavy objects over the cord and do not bend it excessively since it could get damaged. Not following these instructions may result in electric shock, fire, or other hazards.
	When not using the unit for a long time, remove the power plug from the electric outlet.

# 1. Safety Instructions (continued)

- Follow all warnings and instructions marked on the unit.
- This product is meant to be operated in an indoor environment with proper ventilation.
- Do not place near direct sunlight, heat sources, or air conditioners.
- This product should only be operated with the power cord supplied and the type of power source indicated in this user guide. If you are not sure of the type of power supply in your location, consult your vendor or local power company.
- To avoid the risk of fire or electric shock, never push objects into the unit through the case slots or openings since they may touch dangerous voltage points or shortcut parts. Do not disassemble the unit.
- Never spill liquids of any kind on the product.
- Unplug this product from the wall outlet and refer servicing to qualified service personnel under the following conditions:
  - When the power supply cord or plug is damaged or frayed\*
  - If liquid has been spilled into the unit, or it has been exposed to rain or water\*
  - If the product has been dropped or the case has been damaged\*
  - If the product shows a noticeable change in performance

\*Not covered under warranty

**NOTE:** Do not remove the "ground" prong from the power cord. It is a safety feature meant to protect the user from harm and the equipment from damage.



If the unit does not operate normally while following the instructions, adjust only those controls covered by the operating instructions. Improper adjustment of other controls may result in damage and will often require extensive work by a qualified technician to restore the product to normal operation.

## 2. Equipment Overview

1. LED Indicator Display
2. Feeding Channel
3. Magnetic Bill Thickness Adjuster
4. Bill Exit Slot
5. Power Switch
6. Power Adapter Connector
7. Serial Port
8. USB Interface Port
9. Mini SD Card Port

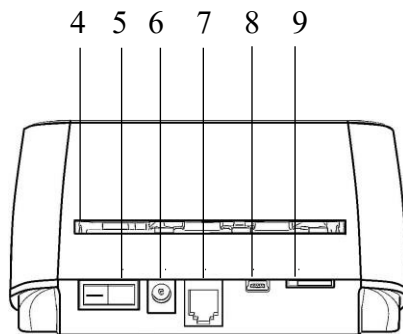
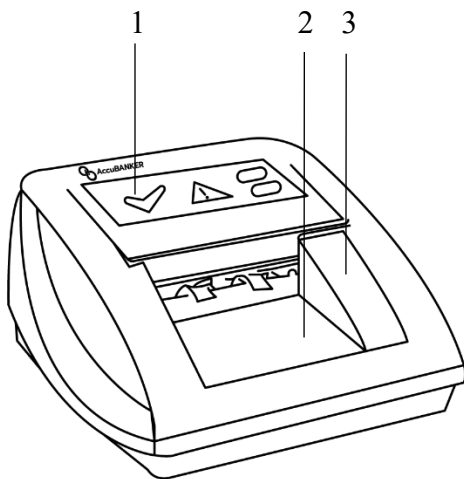

## 2. Equipment Overview (continued)

10. Currency Indicator

11. Green Indicator ✓

12. Red Indicator ⚠

13. Control Buttons

14. Grips for the AccuStand metal base

15. Battery compartment (*Optional & Sold separately*)

16. AccuStand (*Optional & Sold separately*)

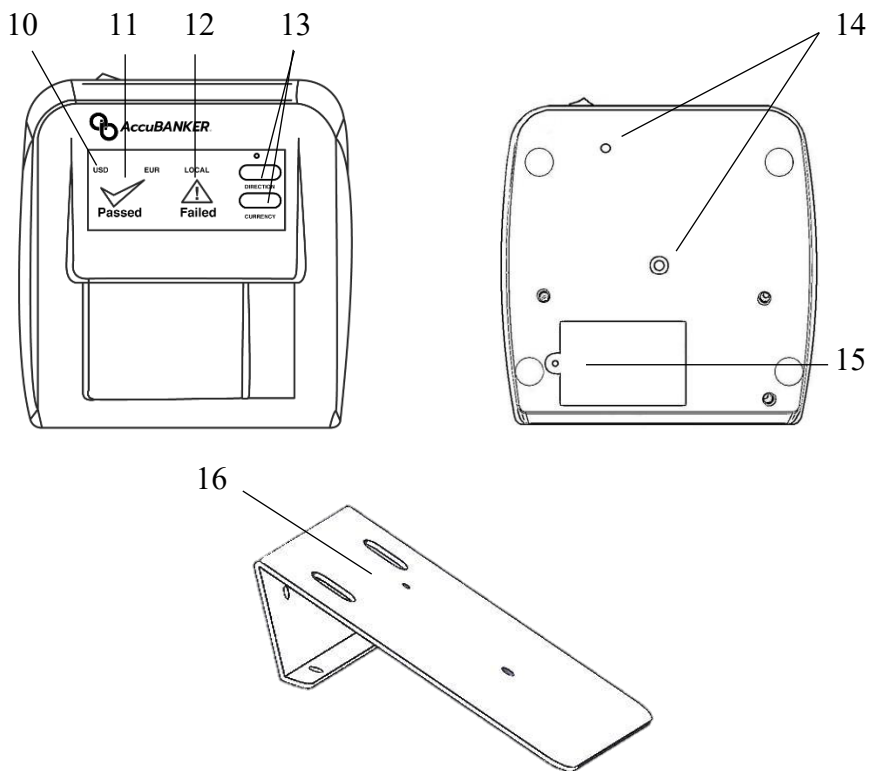



### 3. Control Panel Description

1. **Currency Indicator** - Indicates which currency has been selected to be verified (USD, EUR, LOCAL).
2. **Battery Life Indicator** - When the optional rechargeable battery is used this will indicate the battery's state of charge. The indicator will flash when the unit is charging. Each stage of the battery life is indicated as follows:
  - Red: 20% or less (charge needed)
  - Yellow: 20% to 70%
  - Green: 70% or more

**Note:** Rechargeable battery is optional and sold separately. When the unit is connected to a power source the indicator will be red.

3. **Direction** - The user can change the direction that the bill will exit the equipment, based on their preference. A "Passed" bill can be retrieved through the back of the unit or returned through the feeding channel. Press and hold the DIRECTION button to change the bill output direction, the indicator will illuminate on the screen. Failed bills will always return through the feeding channel.

### 3. Control Panel Description (continued)

- Currency** - The user can switch between three pre-programmed currencies: USD, EUR, and LOCAL. LOCAL is programmed to verify the local currency of the country from where the unit was originally purchased. To change between or select the currency to be verified, press and hold the CURRENCY button.
- Passed Bill Indicator** - A green ✓ and a single beep will confirm the bill has PASSED the detection test.
- Failed Bill Indicator** - A red ⚠ and three beeps will alert and confirm the bill has FAILED the detection test.

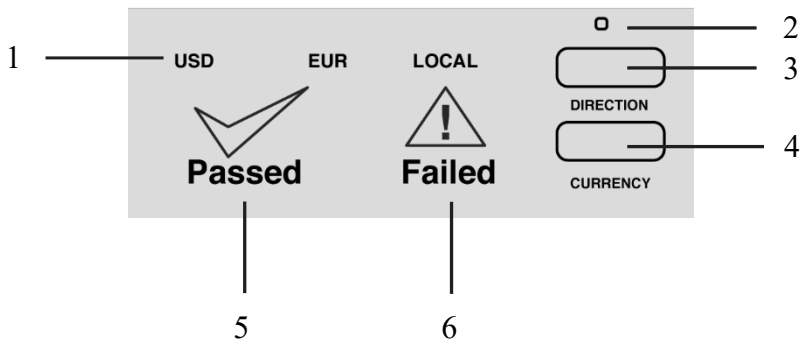

## 4. Operation

### 4.1 Basic Operation

1. Connect the power cable to the detector and then connect the adapter to the power outlet. Once the detector is plugged in, the user can turn the power switch ON. As the detector powers up, it will proceed with a self-check routine that will last a few seconds. The green indicator ✓ will illuminate, meaning the equipment is ready for use.
2. Confirm that the currency indicated on the screen (USD-EUR-LOCAL) matches the currency that will be verified. To change between currencies, press and hold the "CURRENCY" button.
3. Insert the bill, facing in any direction, by following the guiders. Instructions on the unit will also help align and guide the user to insert the bill. When a bill is inserted into the detector's feeding channel, an optical sensor located within this compartment, automatically recognizes and passes the bill through the chamber, to perform the verification process in less than a second.
4. If the bill has passed the detection test, the green indicator ✓ will illuminate on the screen and a single warning beep will confirm.
5. If the bill has not passed the detection test, the red indicator ⚠ will illuminate on the screen followed by two warning beeps.

## 4. Operation (continued)

### 4.2 Suspicious Bill Warning

This equipment uses a complex system of sensors to verify the many security characteristics each bill contains. These characteristics include: Magnetic (MG), Infrared (IR), Watermark (WM), Ultraviolet (UV), and other properties. If any of these security features do not pass the authentication process, the red indicator will display  followed by two warning beeps, to alert the user. If a bill is detected as suspicious, we recommend passing the bill at least three more times in different positions. Non-counterfeit bills can also be rejected due to different reasons, such as:

- Bills are too crumpled
- Bills are very stained or dirty
- Bills are damp, wet, and/or ripped
- Bills are stuck with adhesive tape or stapled
- Wrong currency was selected
- Bills were not inserted following the guiders

## 4. Operation (continued)

### 4.3 Bill Positioning

- This equipment has the ability to verify the authenticity of bills facing in any direction.
- For correct verification, the bill must be inserted into the feeding channel straight-on, well-aligned, and all the way to the left edge, using the guiders. Use figures "A" and "B" for reference.
- Avoid inserting the bill into the feeding channel in any way that is not aligned with the guiders, such as: separated from the left side and/or at an angle. Use Figure "C" for reference.
- If the bills are too thick for the Feeding Channel, remove the Magnetic Thickness Adjuster. However, the Thickness Adjuster should always be used when the size of the bill allows.

A

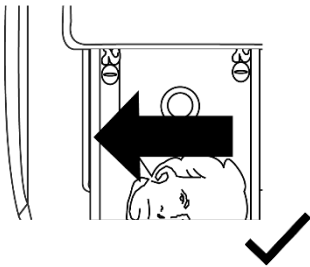

B

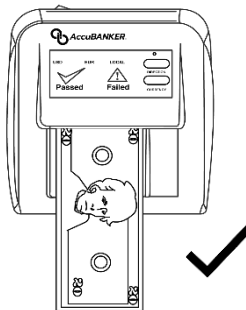

C

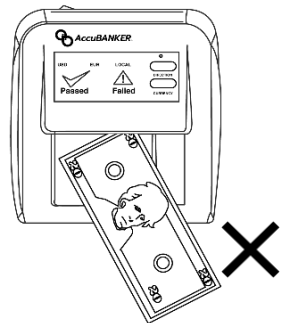

## 5. Troubleshooting & Maintenance

### 5.1 Preventive Measures

For optimal operation, it is important to note the following:

1. Avoid direct exposure to powerful sources of light as well as magnetic interference (ex. microwave, cell phone, or WiFi devices), which will affect the sensors within the detector.
2. Keep the sensors clean.
3. Keep the equipment off when not in use for an extended period of time.
4. Check the quality of the bills and avoid:
  - Bills that are or have been stapled
  - Bills with clips, adhesive tape, or other glue
  - Bills that are broken or badly damaged
  - Bills that are damp or wet
  - Bills affected by chemical agents of any kind

### 5.2 Jamming

If a bill or any other object accidentally jams inside the detector:

1. Turn off the detector immediately.
2. Carefully proceed to remove the bill or object causing the problem.
3. Turn on the detector again and verify it is working at an optimum level.

To avoid jamming, please:

- Keep any and all foreign objects that could accidentally fall into the equipment (clip, tape, etc.) away from the unit.
- Position bills correctly before inserting them into the feeding channel.
- Make sure the bill is in good condition, following the suggestions mentioned previously. (see Section 5.1 for more information)

## 5. Troubleshooting & Maintenance (continued)

### 5.3 IR Sensor Calibration

If the detector is rejecting an unusual amount of bills, the equipment may need to have the sensors calibrated.

1. Use conventional office paper (75 - 80g) to print and cut the D480 IR Calibration template to perform the calibration. Download the template from [www.accubanker.com/pages/support/D480](http://www.accubanker.com/pages/support/D480).
2. Turn off the detector.
3. Press and hold the DIRECTION and CURRENCY buttons, turn the unit on and wait until the unit beeps four times before releasing the buttons.
4. Insert the paper through the feeding channel as if scanning a bill, the unit will begin flashing both indicators intermittently, leave the paper inside the unit for a few seconds while it calibrates the IR sensors. (Use Figure 1 for reference)
5. The unit will give a two-beep warning and the red indicator  will turn off, once the calibration is complete.
6. Turn off the detector and remove the paper.

Please scan with your smartphone the QR Code to find more info



Figure 1

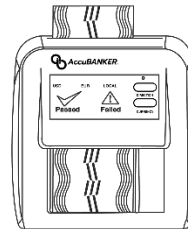

## 5. Troubleshooting & Maintenance (continued)

### 5.4 Maintenance



**CAUTION:** Before performing any cleaning process, turn off the equipment and unplug it. Please note that problems or defects caused by lack of maintenance are not covered under the warranty.

This equipment should always be kept and placed in a clean, dust-free environment. It is necessary to clean the interior of the equipment once a month or more frequently, depending on use. Turn off and unplug the detector before proceeding with this operation.

Use the following methods to keep the interior & the unit clean:

- Use compressed air to remove dust from the inside.
- Use a Cleaning Card to remove dust particles adhering to the magnetic heads.

Visit [www.accubanker.com](http://www.accubanker.com) to purchase a cleaning kit.

### 5.5 Cleaning the Magnetic Heads

1. Turn on the detector and insert a magnetic head cleaning card through the detection channel as if you were going to check a regular bill.
2. Pass the cleaning card several times to help remove dust that is adhering to the surface of the magnetic heads. Wait about two minutes before proceeding to check bills again.

Visit [www.accubanker.com](http://www.accubanker.com) to purchase a cleaning kit.



## 6. Software Updates

To perform the software updates, follow these steps:

1. Visit [www.accubanker.com/pages/support/D480](http://www.accubanker.com/pages/support/D480) to check if a software update is available. If there is an update, download and copy the programming software to a mini SD card.
2. Turn off the detector.
3. Insert the mini SD card into the update port at the back of the unit.  
(Use the image below as a reference)
4. Turn on the detector. The two LED indicators in the display, ✓ and ⚠, will flash intermittently during the programming process.
5. Wait approximately 30 seconds until the detector finishes the update. The red indicator will turn off to show that the new software installation is complete.
6. Turn off the detector and remove the SD card.
7. Turn on the detector and check the update.

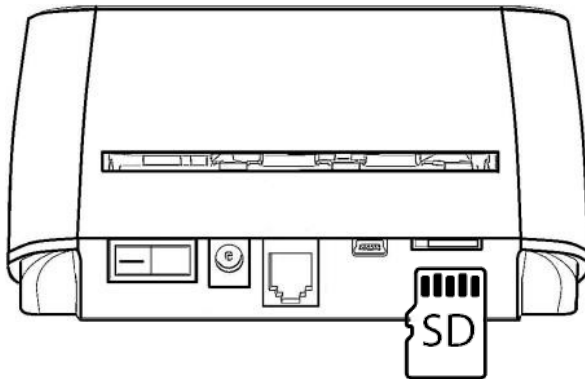

## 7. Specifications

**Ambient Temperature Range:** 32° - 104°F (0° - 40°C)

**Ambient Humidity:** 25% - 80%

**Display:** LED indicator

**Processing Speed:** Less than 1 second (Approx.)

**Power Adapter:** Input 100 - 240V AC / 60-50 Hz 0.6A

Output 12V DC / 1.0 A

**Power Consumption:** < 5W

**Dimensions:** 5.7 in x 5.9 in x 3 in (14.5 cm x 15 cm x 7.6 cm)

**Weight:** 1.15 lbs. (0.52 kg)



AccuBANKER USA  
7104 NW 50th St  
Miami, FL 33166  
9AM- 5PM ET Monday through Friday  
[www.AccuBANKER.com](http://www.AccuBANKER.com)  
Please give us a call at 1-888-993-2228