



**CHILDREN'S BALANCE BIKE**

**ASSEMBLY INSTRUCTIONS &  
SAFETY GUIDE**

# Manual

|                            |    |
|----------------------------|----|
| CONGRATULATIONS            | 3  |
| SAFETY REFERENCES .....    | 3  |
| ASSEMBLY INSTRUCTION ..... | 5  |
| CARE AND MAINTENANCE ..... | 8  |
| WEAR PARTS .....           | 9  |
| WARRANTY .....             | 9  |
| SERVICE .....              | 9  |
| SAFETY CHECKLIST .....     | 10 |



Pay particular attention to sections with this sign. This information is very important and security relevant.

## US THANK YOU & CONGRATULATIONS

Thank you and congratulations for the purchase of your TykesBykes children's balance bike.

**Please read this safety notice and assembly instructions before using the balance bike. Store these instructions together with the purchase receipt.**

# SAFETY REFERENCES

ATTENTION!

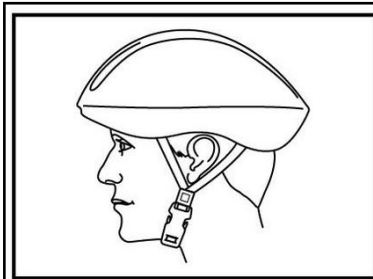

## Helmets

It is strongly advised that a properly fitting, ANSI or SNELL, or CSA certified, bicycle safety helmet be worn at all times when riding your bicycle. In addition, if you are carrying a passenger in a child safety seat, they must also be wearing a helmet.

The correct helmet should:

- be comfortable
- be lightweight
- have good ventilation
- fit correctly
- cover forehead



Always wear a properly fitted helmet which covers the forehead when riding a bicycle. Many provinces require specific safety devices. It is your responsibility to familiarize yourself with the laws of the province where you ride and to comply with all applicable laws, including properly equipping yourself and your bike as the law requires.

- ⚠ WARNING! STRANGULATION HAZARD - LONG CORD
- ⚠ WARNING! CHOKING HAZARD - SMALL PARTS
- ⚠ WARNING! ADULT ASSEMBLY REQUIRED
- ⚠ This children's balance bike is a toy. Always make sure that the balance bike is used properly.
- ⚠ This balance bike does not adhere to the Road Traffic Licensing Regulations and may therefore not be used in traffic.
- ⚠ **Please ensure that this balance bike is only used in suitable play areas, never near stairs, on steep ground, or by swimming pools or other bodies of water.** If there are any steps or stairs in the area, they must be screened off so that children cannot ride up or down them on their bikes.
- ⚠ The manufacturer cannot be held responsible or made accountable for damage that is a result of usage other than that specified in the documentation.
- ⚠ Check regularly that the balance bike is in full working order (especially the brake) and that all screws are fully tightened, especially those of the saddle and handlebars.
- ⚠ Always make sure that the young rider wears suitable protection. It is essential that proper shoes and a cycling helmet be worn at all times!

⚠ Even though this balance bike fulfills all US and European standards for toys and any dangers during play have been minimized, the safe handling of this balance bike requires some skills that your child may have to learn. Please ensure that you supervise your child and instruct him/her in how to properly use this balance bike. Be sure to also point out any potential dangers to your child.

⚠ This balance bike is not suitable for children who weigh more than 50 kg (110lbs).

⚠ This balance bike is not designed for tricks, stunts, or off-road use.

⚠ Please read the assembly and user manual before using the balance bike.



- Valve caps need to be firmly tightened and kept out of children's reach (danger of swallowing).

Look for us on and Share your riding pictures and videos

**facebook**

<https://www.facebook.com/TykesBykes2011>



Scan with your phone for Facebook

# ASSEMBLY INSTRUCTIONS

## Follow these easy steps

1. Remove Packing Materials
2. Install Handle Bars
3. Install Seat & Post
4. Install Front Wheel
5. Set up the Hand Brake
6. Adjust to fit

## Remove Packing Materials

Carefully remove your bicycle from the box, you will need to remove the protective cardboard and bubble wrap from the frame.

You will also need to remove plastic caps from the wheel axle nuts, the top of the head tube, a plastic cover on the end of the stem bolt wedge and a small grey cap covering the stem bolt

Leave the plastic wedge in the front fork as this will steady the bike during assembly.

# Handlebars

Stand the bike upright on the rear wheel and front fork, ensure to remove the plastic end caps exposing the Stem Wedge Bolt and the Stem Wedge. Insert the bars into the frame, you may need to loosen the Stem Wedge Bolt to allow the Stem Wedge to pass into the frame. Ensure that the "Minimum Insert" line is not visible.

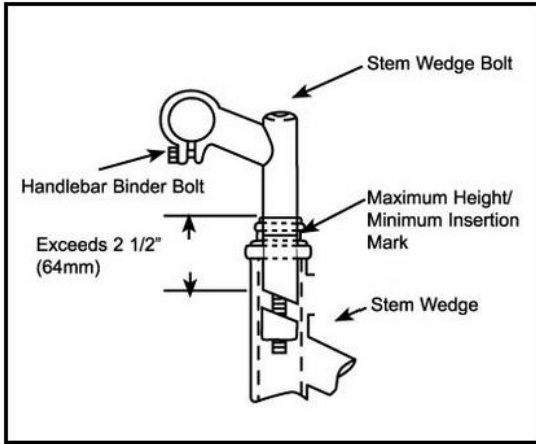

Using the wrench provided tighten the Stem Wedge Bolt, as the bars become tight straighten the bars so that they face forwards.

By loosening the Handle Bar Bolt, the handle bars can be rotated forwards or backwards to assist in sizing the bicycle. Ensure this bolt is securely tightened before use.



Please note the stamped markings "MINIMUM INSERT" on the handlebar mounting. This marks the minimum length to which the handlebars should be inserted into the front stem. The handlebars should not under any circumstances be fixed higher than this marking.

## Seat & Post

Open the lever on the Quick Release Seat Post Clamp, insert the Seat Post into the frame. Ensure that the "Minimum Insert" line is not visible. Leave the seat set high at this point, with the saddle facing the front of the bike.

Close the Quick Release (the lever should be facing the front of the bike). The Lever should leave an impression on your hand, to tighten the lever, open the lever halfway and hand tighten the bolt on the other side and then close the lever again.



Please note the stamped markings "MINIMUM INSERT" on the saddle mounting. This marks the minimum length to which the saddle should be inserted into the frame. The saddle should not under any circumstances be fixed higher than this marking.



## Front wheel

On a clean smooth surface flip the bike over and rest the bike on the saddle and handle bars, (Setting the bike upside down on a rough surface like gravel could damage your seat or handle bars).

Loosen the bolts on either side of the front wheel. Like at the direction of tread on the back wheel and turn the front wheel so the tread is facing the same direction. Insert the wheel into the fork and place the safety washers on both sides of the axle. Be sure to pay attention to the arresting plug (Fig. 1). Then fully tighten the cap nuts.

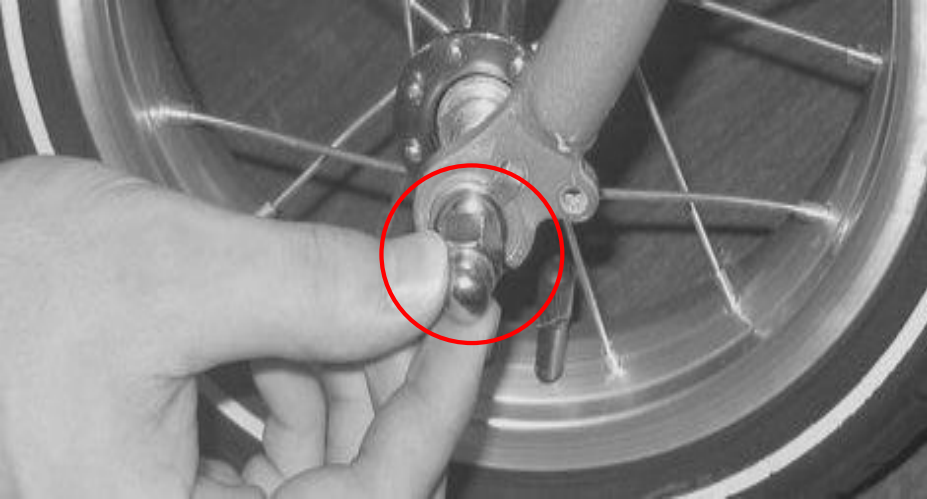

[Fig. 1]



## Set up the Hand Brake Hand Brake

Adjust the lever stroke so that it fits the hand size of your child. This is achieved using the regulating screws on the brake lever (Fig. 5). Set a length of travel that allows your child to easily and safely reach the lever without having to remove the ball of the hand from the handlebars. Adjust the lever stroke of the brakes directly at the brake unit by opening the screw (Fig. 4) and by either tightening or loosening the brake wire, as necessary.

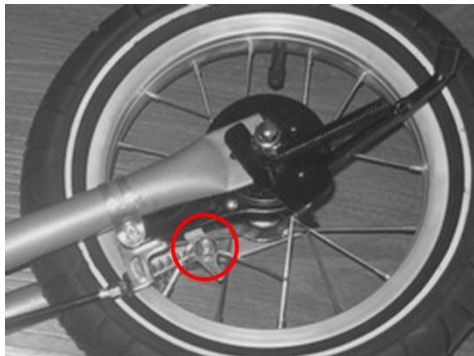

[Fig. 4]

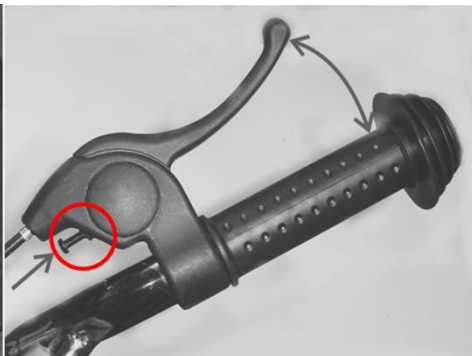

[Fig. 5]

## Tire Inflation

When leaving the factory tires are only filled to 50% of recommend pressure and will often loose additional air during transit. Before riding your bike for the first time inflate your tires to the maximum pressure as rated on the side of the tire. This will seat the tire correctly on the rim and reduce wobble. For smaller riders we recommend that you then drop the pressure back to as low as 15 PSI. The lower tire will increase grip, lower the balance and assist in getting the rider comfortable on the bike.

# CARE AND MAINTENANCE

- ⚠ Repeat the assembly procedure at regular intervals. For safety reasons, an initial check should be made after a few riding lessons.
- ⚠ Check the tightness of all boltings regularly.
- ⚠ Check the tire pressure at regular intervals (the prescribed pressure is indicated on the sides of the tires).
- ⚠ Make sure that the handlebar can't twist.
- ⚠ Worn parts must be replaced immediately. If any part is bent, please do not fix it by yourself and replace it with original parts.
- ⚠ Use only spare parts for the balance bike that are specified and approved. Contact us [support@tykesbykes.com](mailto:support@tykesbykes.com) for advice or spare parts.
- ⚠ All maintenance work requires professional expertise. If necessary, involve a professional dealer (expert) for service.
- ⚠ Only use environmentally friendly products and never use any aggressive detergents. Protect the balance bike against thawing salt and avoid long-term storage in damp areas (e.g., garage).

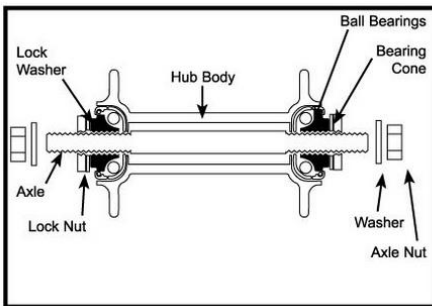

## Hub Bearing Adjustment

When checked, the hub bearings of either wheel will require adjustment if there is any more than slight side play.

1. Check to make sure neither locknut is loose.
2. To adjust, remove wheel from bicycle and loosen the locknut on one side of the hub while holding the bearing cone on the same side with a flat open end wrench.
3. Rotate the adjusting cone as needed to eliminate free play.
4. Re-tighten the locknut while holding the adjusting cone in position.
5. Re-check that the wheel can turn freely without excessive side play.

# WARRANTY

TykesBykes offers a full warranty on all balance bikes for 2 years. Warranty excludes parts damaged through improper use or normal wear (as defined under Wear Parts). If you experience any mechanical issues with the bike, please contact us directly at [Support@TykesBykes.com](mailto:Support@TykesBykes.com).

# WEAR PARTS

Brake cable, brake pads, rims, tires (including tubes), and handlebar grips are classified as wear parts. New parts are available at [www.TykesBykes.com](http://www.TykesBykes.com).

# SERVICE

For questions or problems, please contact your point of purchase or contact us directly at [Support@TykesBykes.com](mailto:Support@TykesBykes.com).

|                                                                                                                                                                                                                      |
|----------------------------------------------------------------------------------------------------------------------------------------------------------------------------------------------------------------------|
| <b>United States of America</b>                                                                                                                                                                                      |
| Customer Support Service<br>TykesBykes LLC<br><a href="http://www.TykesBykes.com">www.TykesBykes.com</a><br><a href="mailto:Support@Tykesbykes.com">Support@Tykesbykes.com</a><br>CALL US TOLL FREE<br>(855)962-7580 |

# SAFETY CHECKLIST

| Questions                                                                                                                                         | Action if not okay                                                                       |
|---------------------------------------------------------------------------------------------------------------------------------------------------|------------------------------------------------------------------------------------------|
| Check all bolts for adequate strength (drop test from 6 inch height falling on wheels: Can you hear a rattle?)                                    | Tighten the screws and replace it if needed. May tighten the screws with Loctite.        |
| Tire tread depths sufficient enough                                                                                                               | Replace it                                                                               |
| Condition of the tube and valve                                                                                                                   | Fix it or replace it                                                                     |
| Wear of rim sidewalls, cracks in the rim                                                                                                          | Replace it                                                                               |
| Axial and/or radial run-out or loose spokes                                                                                                       | Inflation, re lacing (lacing adjustment), or partial or completely replacement of spokes |
| The wheel cap nuts are tightened enough, the threads of the axle bolts and nuts are in good condition, the flat washer with safety hook is hooked | Fix it or replace it                                                                     |
| Handlebar "creaking" and correct adjustment check                                                                                                 | Readjust it or replace it                                                                |
| Brake cables damage and wear check                                                                                                                | Replace it                                                                               |
| Rear brake check                                                                                                                                  | Readjust or replace it                                                                   |
| Wheel are tightened, having no run-out, you can't hear any "creaking" noise                                                                       | Service it, grease it, repair or replace individual parts (e.g., ball bearings)          |
| Head set is tightened, having no run-out, you can't hear any "creaking" noise                                                                     | Service it, grease it, repair or replace individual parts (e.g., ball bearings)          |
| Fork warped or cracks visible                                                                                                                     | Replace it                                                                               |
| Head set warped or cracks visible, screws and threads are okay                                                                                    | Replace it                                                                               |
| Steering warped or cracks visible                                                                                                                 | Replace it                                                                               |
| Porous or damaged grips                                                                                                                           | Replace it                                                                               |
| Seat post warped or cracks visible                                                                                                                | Replace it                                                                               |
| Frame warped or cracks visible                                                                                                                    | Replace it                                                                               |
| Saddle is adjusted correctly, are not damaged, and screws and threads are okay and tightened enough                                               | Readjust it, repair it, or replace it                                                    |
| Seat post clamp cracks visible, screws and threads are okay and tightened enough                                                                  | Replace it                                                                               |
|                                                                                                                                                   |                                                                                          |
|                                                                                                                                                   |                                                                                          |

List of checks and actions is without guarantee of completeness. If necessary, involve a professional dealer (expert) for service.