

Yogiflex Dual Monitor Arm



Yogiflex maximizes the range of depth without compromising available space behind the screens.

Capabilities

- Fits screen sizes 17-32"
- Monitor compatibility: Flat, curved
- Mounting options: Grommet, clamp or thru mount (all mounting hardware included).
- Tilt range: +45 - -45 degrees
- Swivel range: +90 - -90 degrees
- Screen rotation: +180 - -180 degrees
- Weight capability: 1-9 kg
- Stop rotation to limit back movement

Yogiflex dual monitor arms overcome the ergonomic issues presented when mounting and aligning dual monitors in tight spaces. Extremely flexible, these arms can be adjusted flush to the rear of the desk to maximize space.

Designed with shorter forearms and adjustable dynamic upper arms; allowing maximum depth of field and optimum visual ergonomics. Integrated cable management keeps the work surface free from clutter.

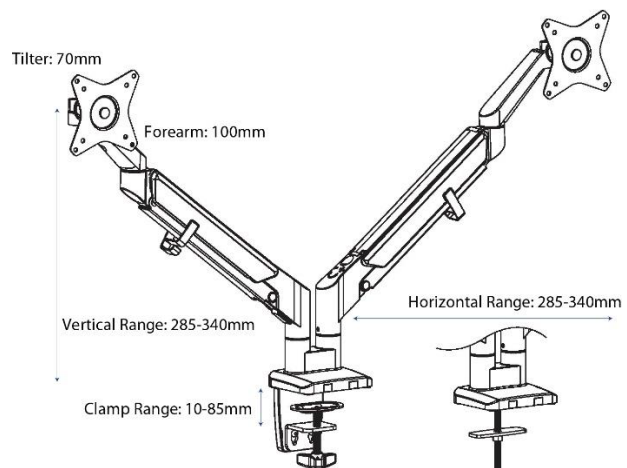

Features

- Specially designed to maximize depth and ease of use for twin monitor mounts
- Sturdy aluminium and steel construction. Polypropylene cable covers.
- Powder-coated finish
- Can accommodate curved monitors
- Quick release VESA brackets, VESA compatible 75 x 75 and 100 x 100 mm.
- Integrated cable management