

ASSEMBLY INSTRUCTIONS

Sapphire Meeting Table

Size: 1800 x 1100 mm

www.jasonl.com.au

Need help!

Call us on
1300 527 665

jason.l
your office furniture mate

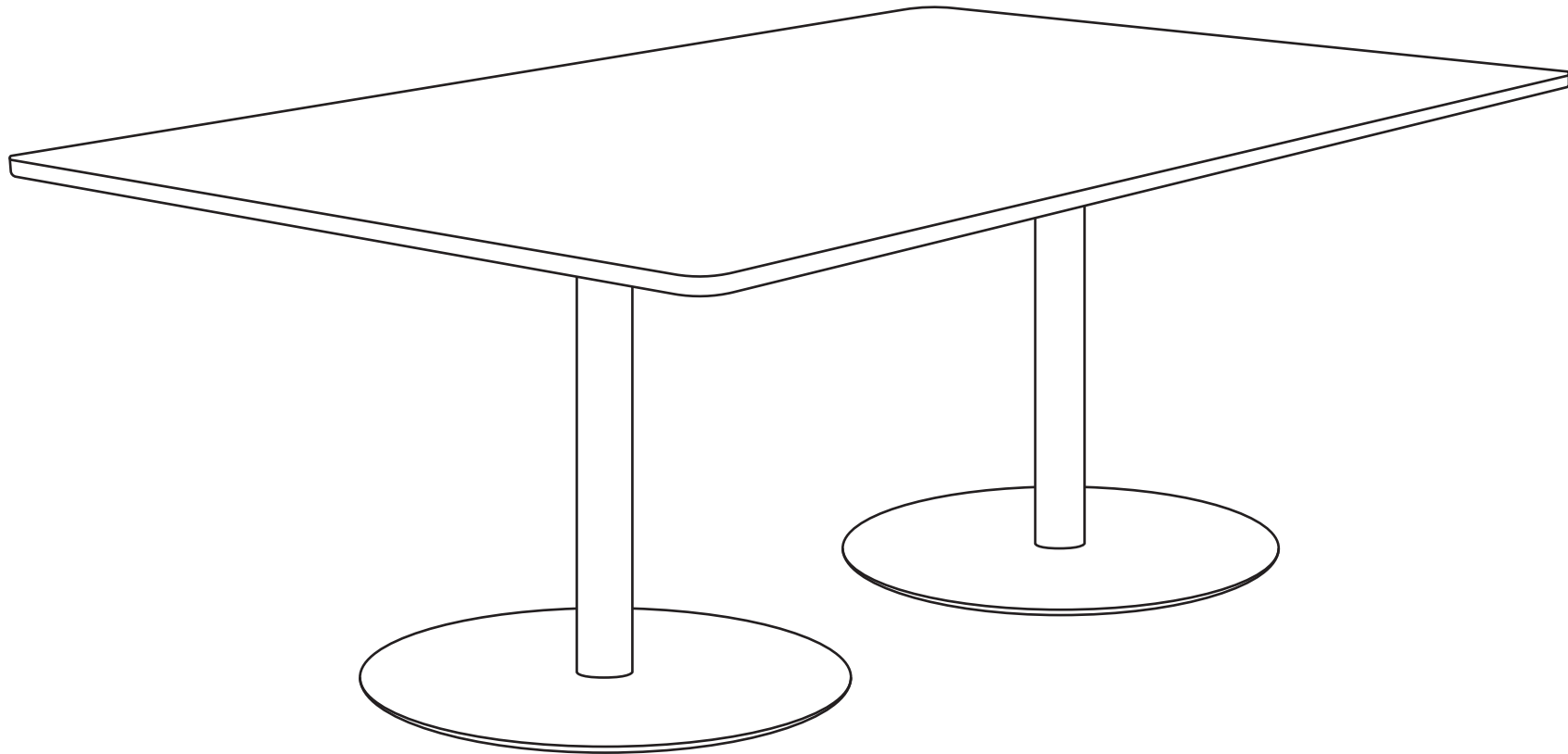

Tools Required: Power screwdriver.

Note: Please ignore any pre-drilled holes or nut inserts that maybe present in your top(s). They will not match your particular table/desk base and woods screws will be required to be screwed directly into the underside of the top.

Note: It is important to fully tighten all bolts and screws before attaching the top(s) so that the frame is sufficiently rigid. Failure to do this may affect stability once the tops are attached.

ASSEMBLY INSTRUCTIONS

Sapphire Meeting Table

Size: 1800 x 1100 mm

www.jasonl.com.au







Need help!

Call us on
1300 527 665

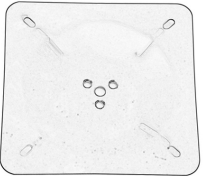
jason.l
your office furniture mate

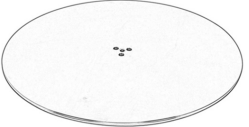

COMPONENTS

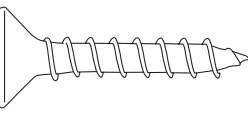
A * 2 	B * 2 
C * 2 	D * 6 (M8*30mm) 
E * 6 (M8*30mm) 	F * 1 
G * 18 woodscrews 	

STEP 1

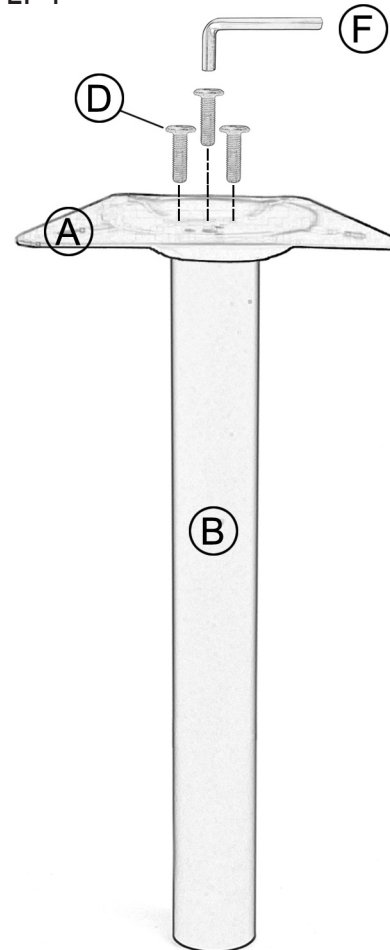

STEP 2



ASSEMBLY INSTRUCTIONS

Sapphire Meeting Table

Size: 1800 x 1100 mm

www.jasonl.com.au

Need help!

Call us on
1300 527 665

jason.l
your office furniture mate



STEP 3

Ask a second person to help turn the table and base over.

Careful: tables are heavy.

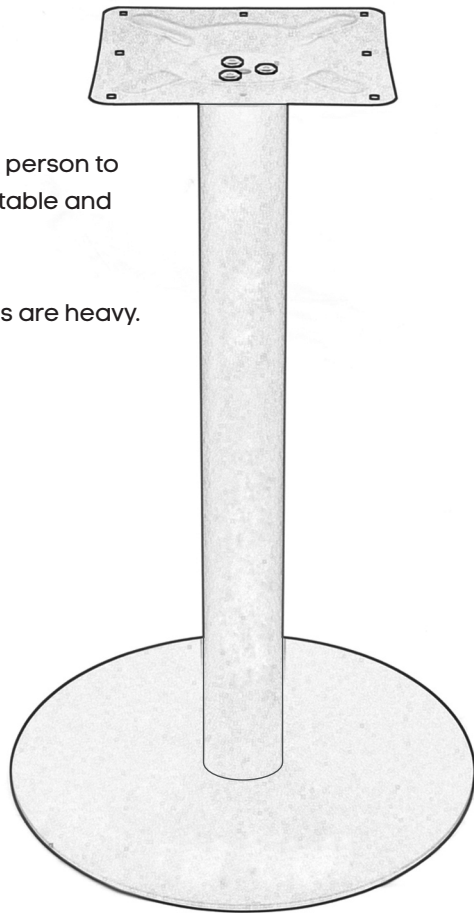

STEP 4

Adding the top

Screw the table top to the bases using woodscrews (G) through the following holes.

NB: Ensure the screws are no longer than 25mm.

