

**ASSEMBLY INSTRUCTIONS**  
**Quadro Wood A leg**  
**Counter table**  
**Radius Corners**

[www.jasonl.com.au](http://www.jasonl.com.au)

**Need help!**  
Call us on  
**1300 527 665**

**jason.l**  
your office furniture mate



Sizes: 3200x1100 mm

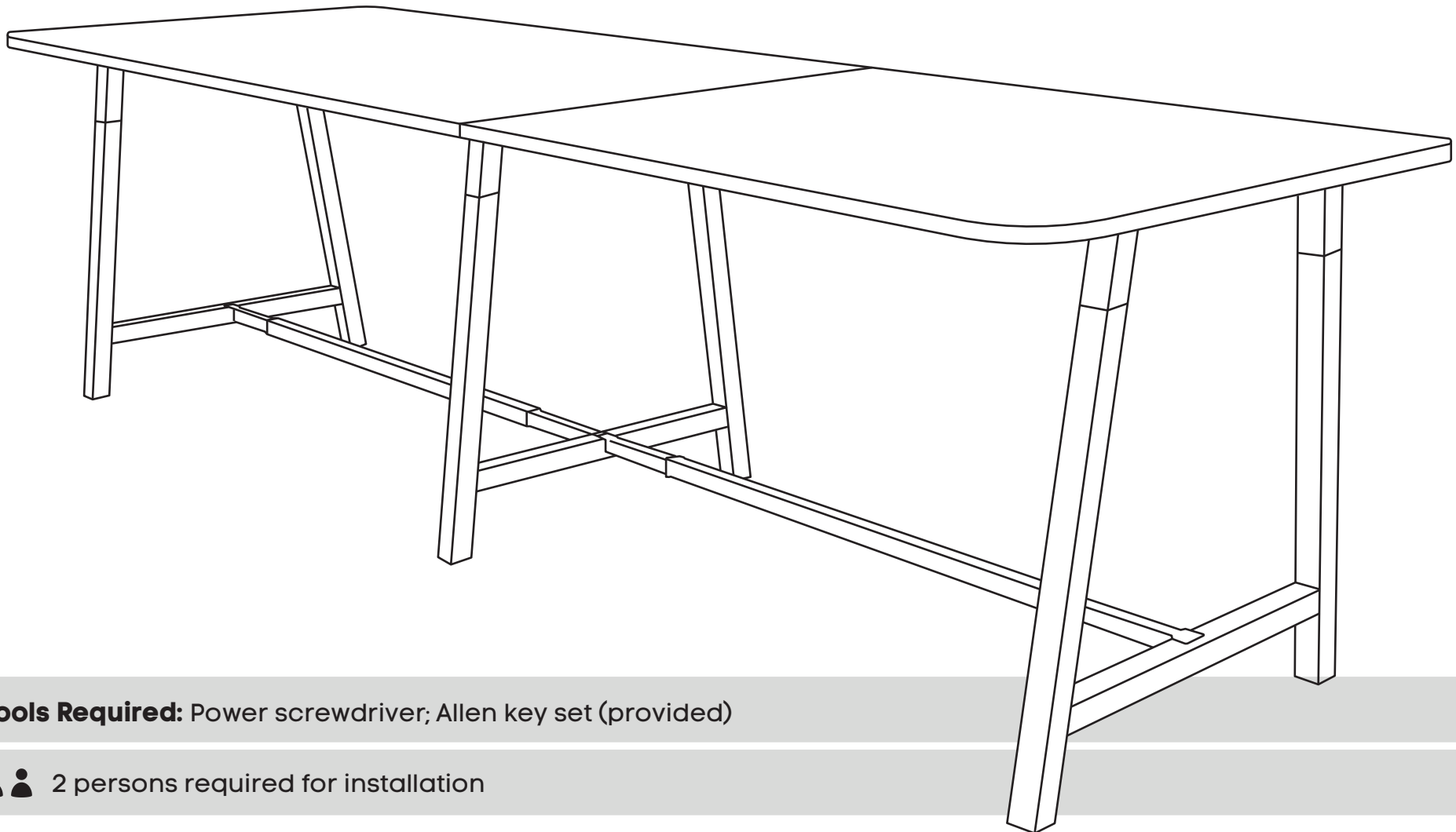

**Tools Required:** Power screwdriver; Allen key set (provided)

 2 persons required for installation

# ASSEMBLY INSTRUCTIONS

## Quadro Wood A leg Counter table Radius Corners

[www.jasonl.com.au](http://www.jasonl.com.au)

**Need help!**

Call us on  
**1300 527 665**

**jason.l**  
your office furniture mate



Sizes: 3200x1100 mm

### COMPONENTS

- A Table top x2
- B Leg Quadro wood A (Half leg) x3
- C Leg wood A add on x6
- D Leg bottom beam x3
- E Upper beam x2 \*
- F Lower beam x2
- G Plastic bracket x8
- H Feet x6

### SCREWS

- I M8x20MM CSK x12
- J M8x20MM socket head x8
- K M6x20MM socket head x6
- L M6x30MM socket head x8
- M Pins x3
- N Corner pads x6
- O Mushroom head M6x30 x6

- P Allen key x2

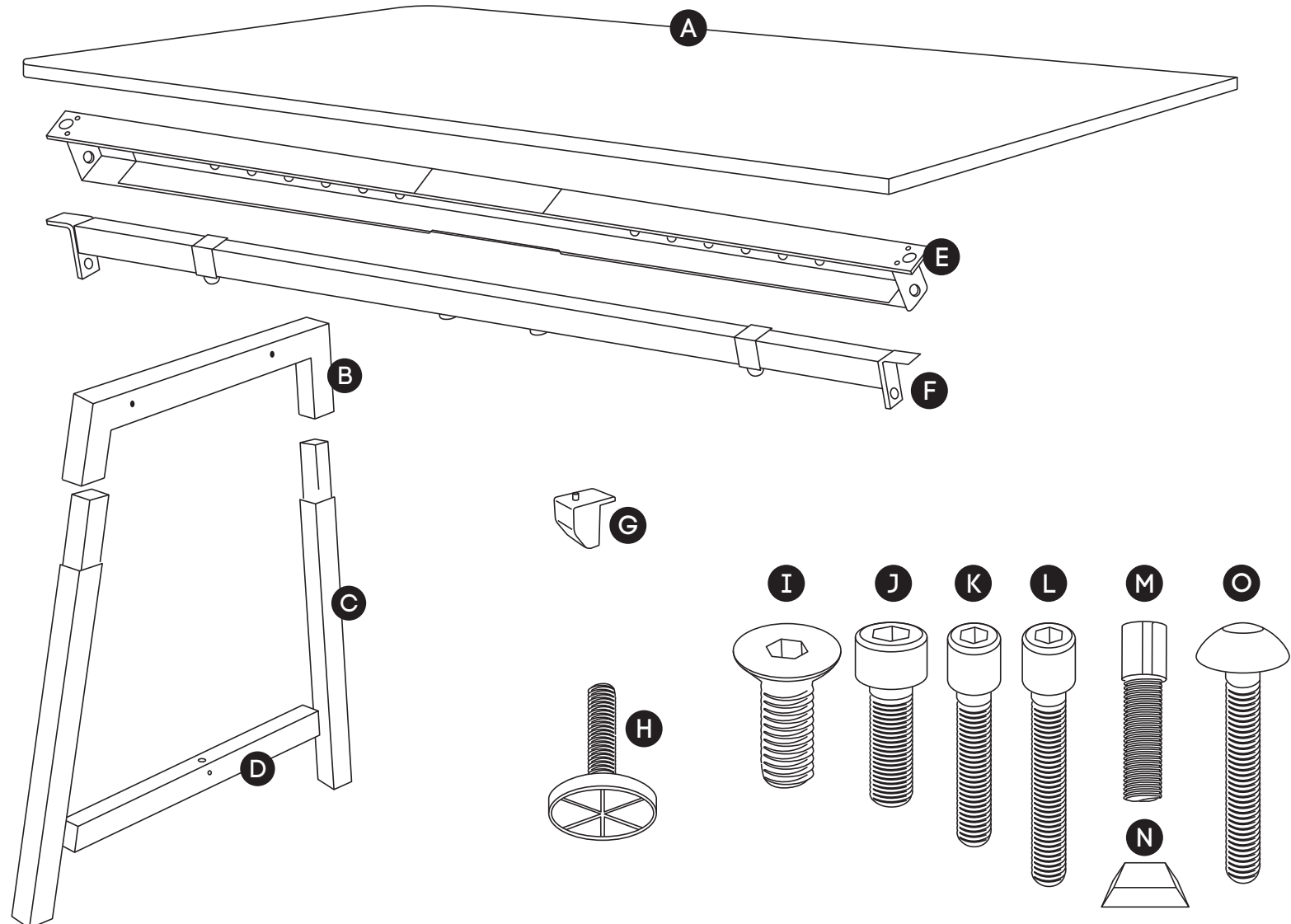

\* Colour of the beam is always black, regardless desk frame colour.

# ASSEMBLY INSTRUCTIONS

## Quadro Wood A leg Counter table Radius Corners

[www.jasonl.com.au](http://www.jasonl.com.au)

**Need help!**

Call us on  
**1300 527 665**

**jason.l**  
your office furniture mate



Sizes: 3200x1100 mm

### STEP 01

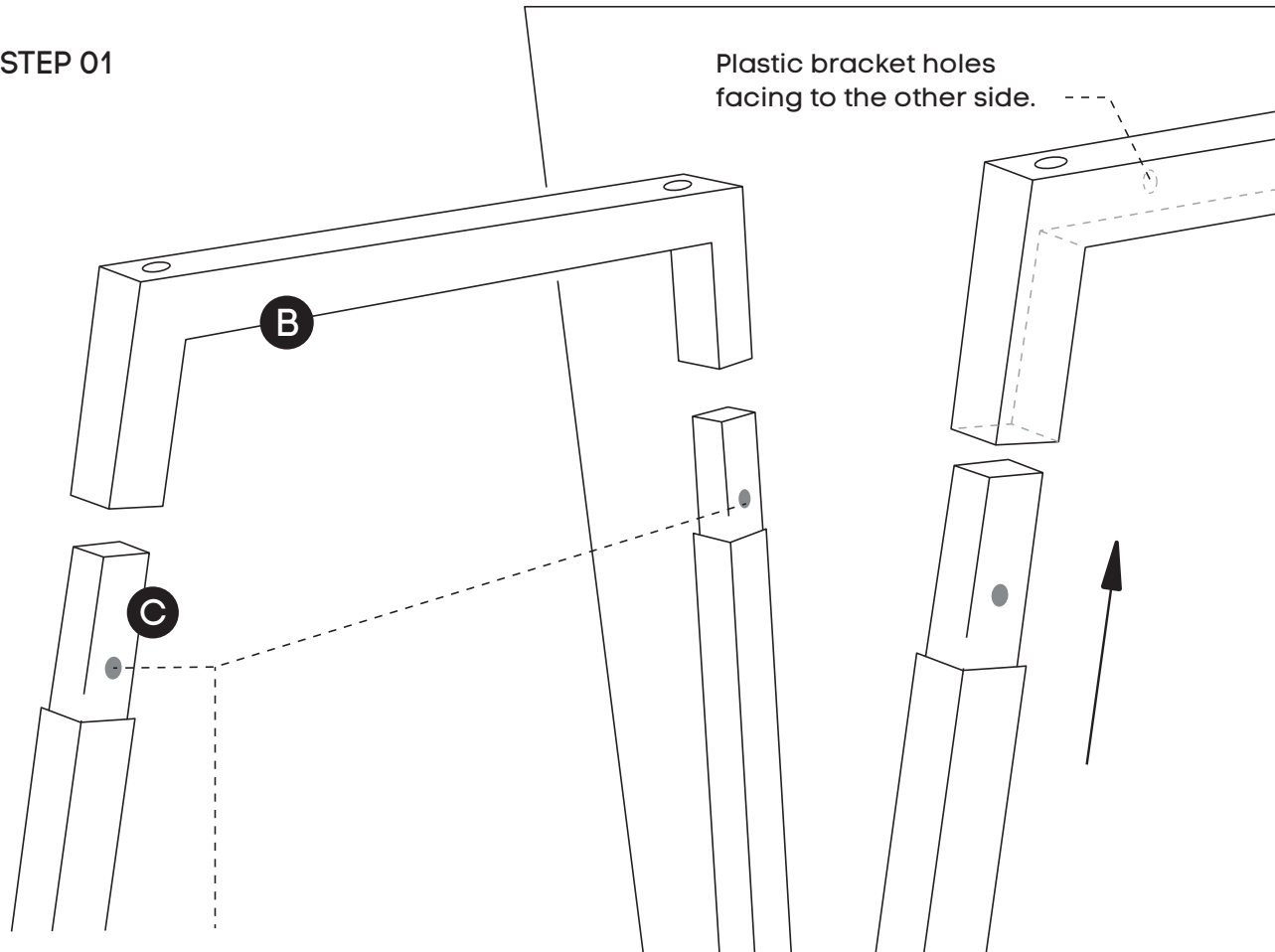

You will notice two colored stickers located on each leg.

Both legs must have the colour sticker facing away from where the plastic brackets are inserted.

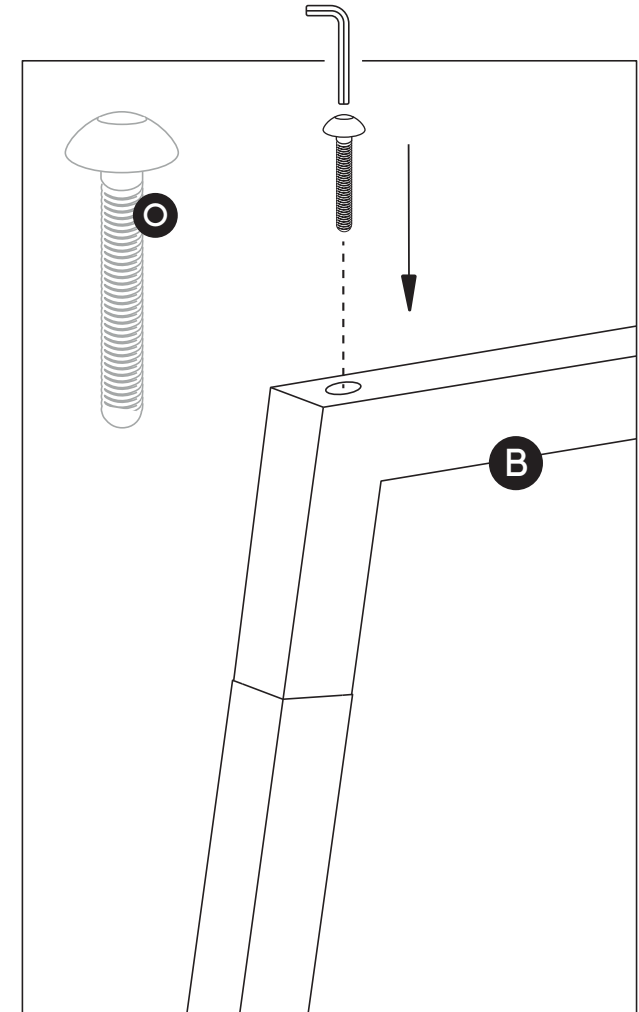

Insert the Leg wood add on (**C**) into the Leg Quadro A (Half leg) (**B**). Using Allen Key provided, attach mushroom head screw (**O**) for all legs.

# ASSEMBLY INSTRUCTIONS

## Quadro Wood A leg Counter table Radius Corners

[www.jasonl.com.au](http://www.jasonl.com.au)

**Need help!**

Call us on  
**1300 527 665**

**jason.l**  
your office furniture mate



Sizes: 3200x1100 mm

### STEP 02

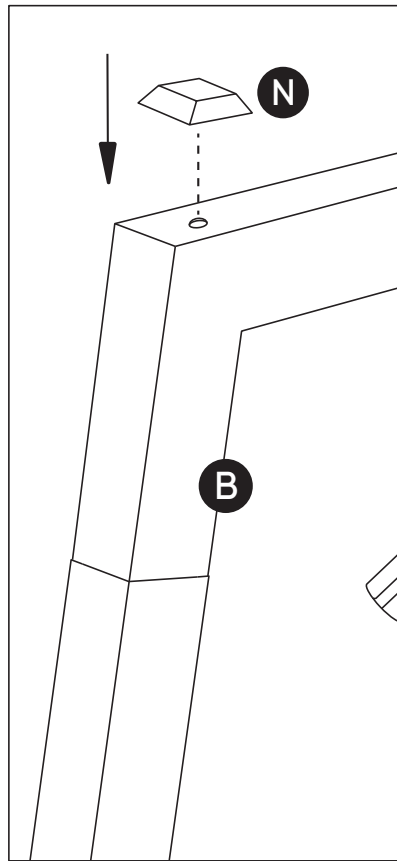

Now use corner pads **(N)** to cover the holes where just inserted the head screw sockets.

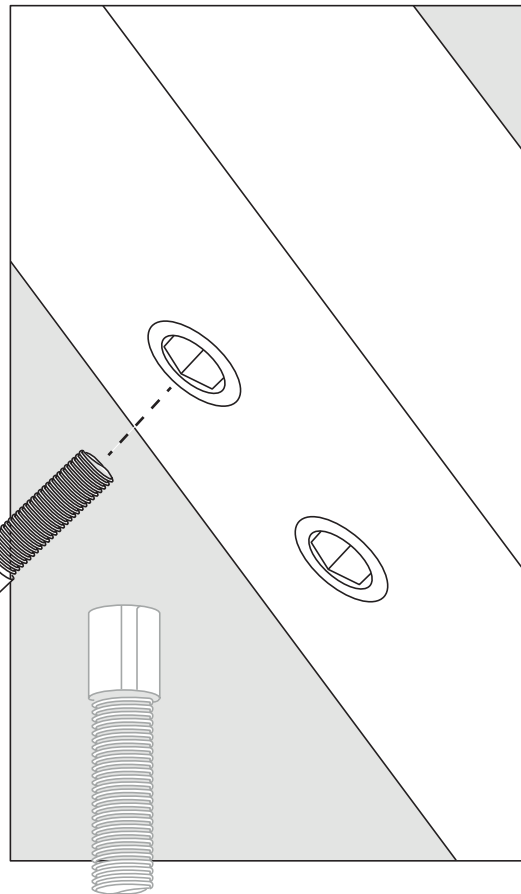

You will notice two holes in each Leg wood add on **(C)**. Insert a Pin into the top hole of each leg, as shown in the illustration.

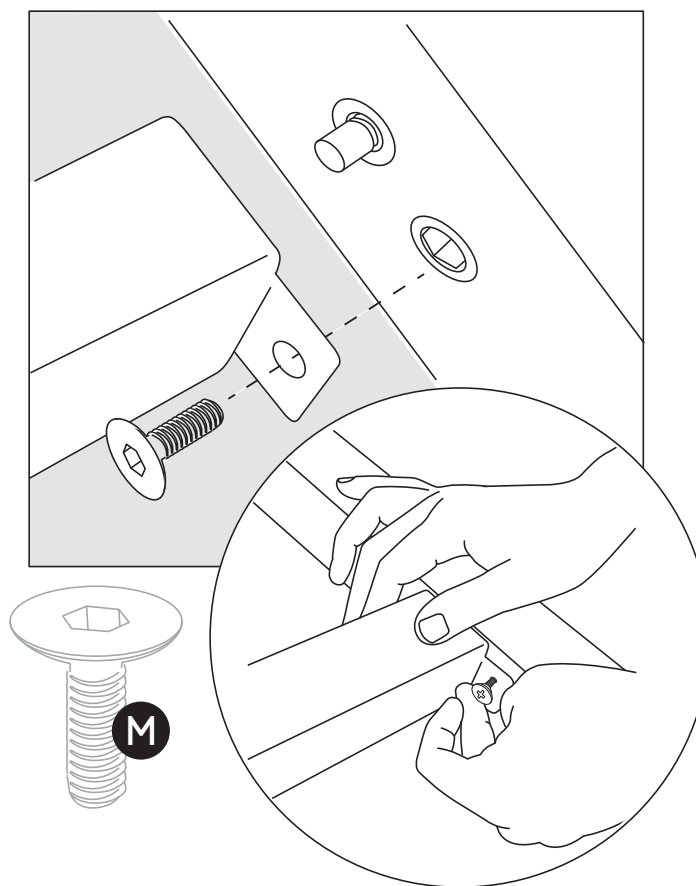

Now insert the Leg bottom beam **(D)** into the Leg wood add on **(C)**, using Pins **(M)** provided. Attach on each leg.

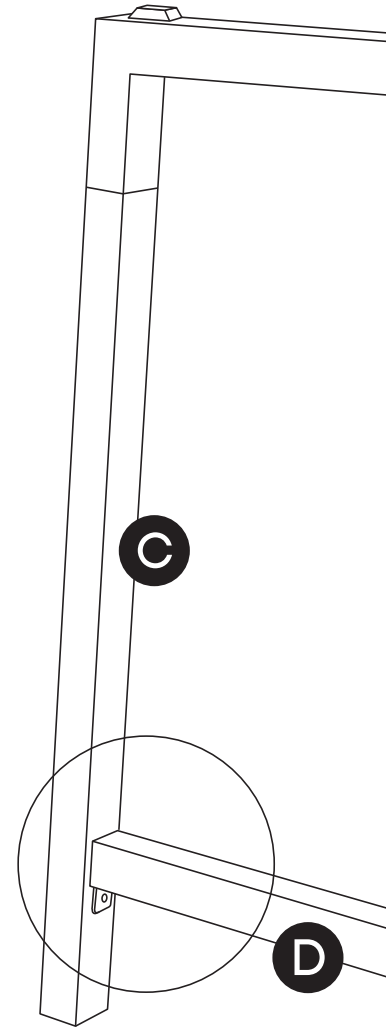

# ASSEMBLY INSTRUCTIONS

## Quadro Wood A leg Counter table Radius Corners

www.jasonl.com.au

Need help!

Call us on  
1300 527 665

**jason.l**  
your office furniture mate



Sizes: 3200x1100 mm

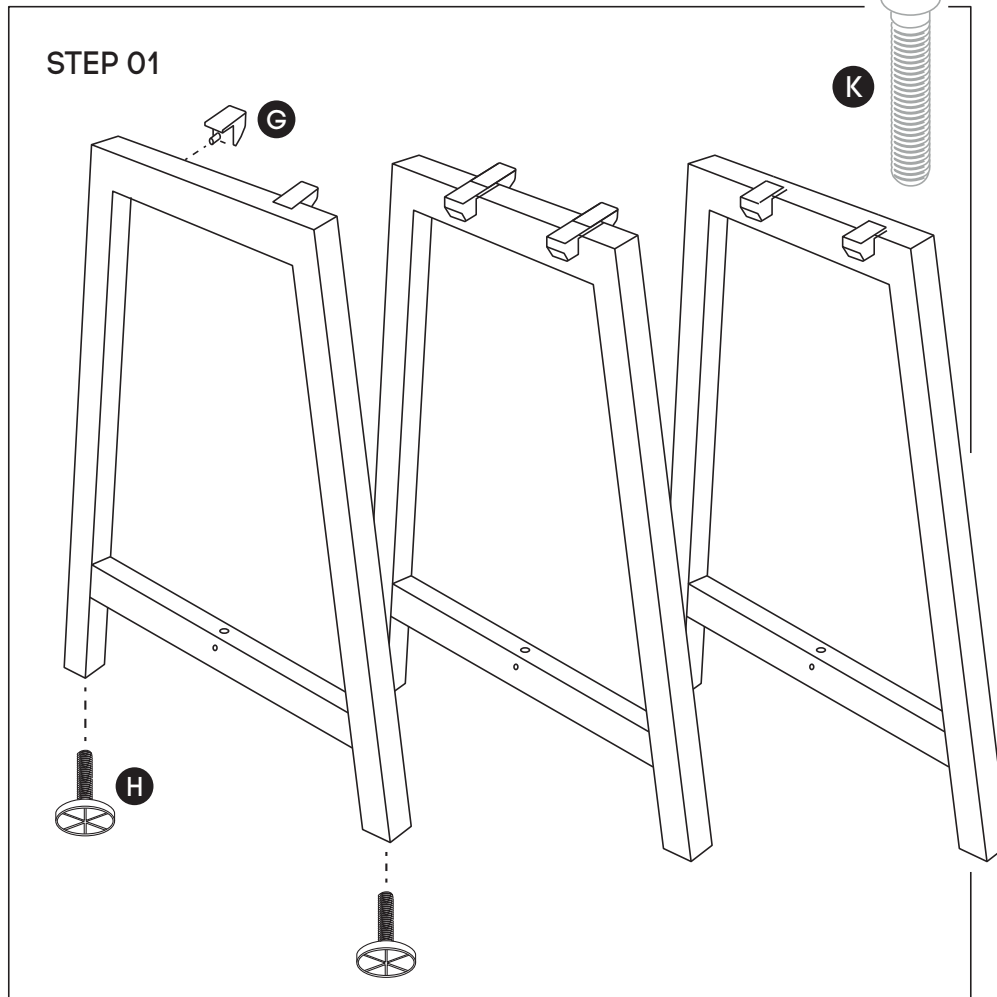

Using Allen Key provided, attach 2 plastic brackets (**G**) per exterior leg, and 4 plastic brackets for the shared leg (as per picture above) using M6x20MM (**K**) Socket head screw. Screw the feet (**H**) to the bottom of each Leg wood add on (**C**).

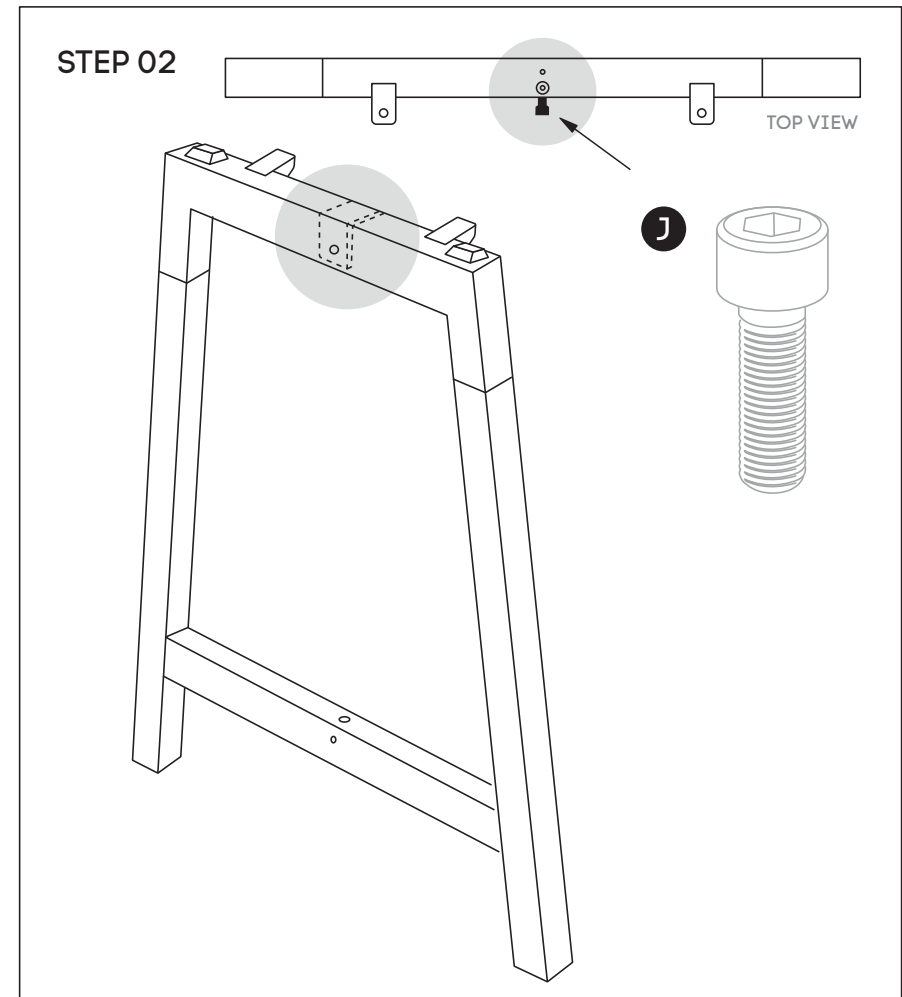

Using Allen Key provided, attach M8x20MM Socket head (**J**)-screw socket half way into leg for all legs

# ASSEMBLY INSTRUCTIONS

## Quadro Wood A leg Counter table Radius Corners

[www.jasonl.com.au](http://www.jasonl.com.au)

**Need help!**  
Call us on  
**1300 527 665**

**jason.l**  
your office furniture mate



Sizes: 3200x1100 mm

### STEP 03

Adjust extendable beam **(E)** to desired length using markers and secure beam at that length using screws provided

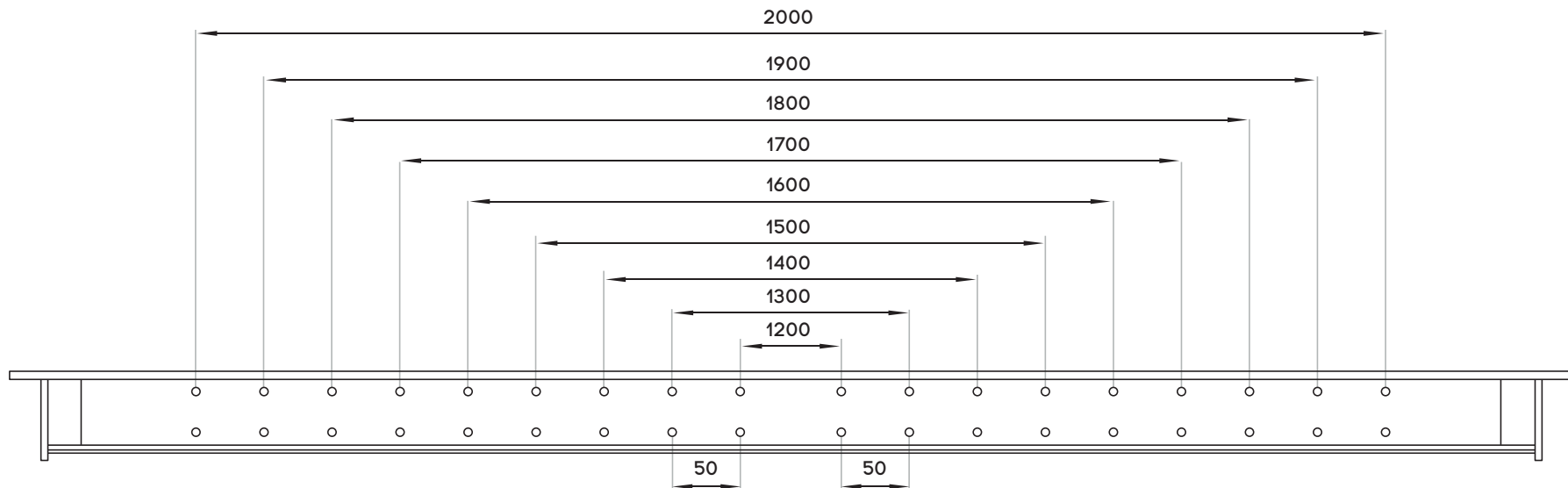
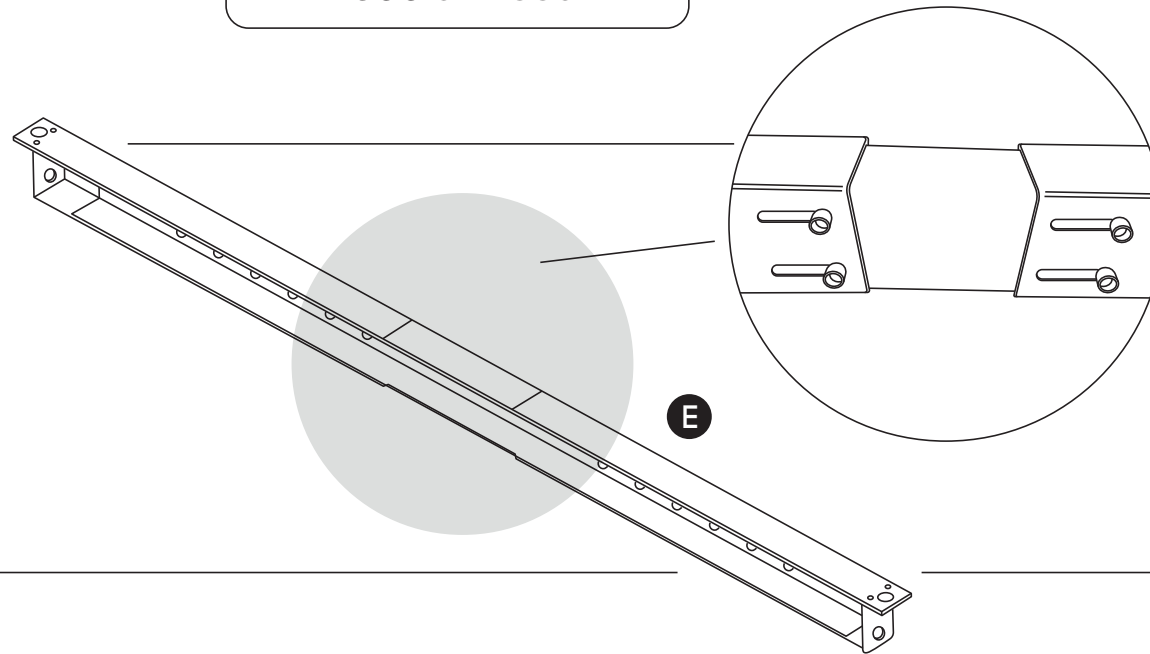

# ASSEMBLY INSTRUCTIONS

## Quadro Wood A leg Counter table Radius Corners

[www.jasonl.com.au](http://www.jasonl.com.au)

**Need help!**

Call us on  
**1300 527 665**

**jason.l**  
your office furniture mate



Sizes: 3200x1100 mm

### STEP 04

Adjust extendable beams (**F**) to desired length.

- 1 Remove plastic inserts
- 2 Loosen 2 bolts on beam using allen key
- 3 Extent lower beam to the same distance as upper beam
- 4 Insert plastic inserts back into the beam

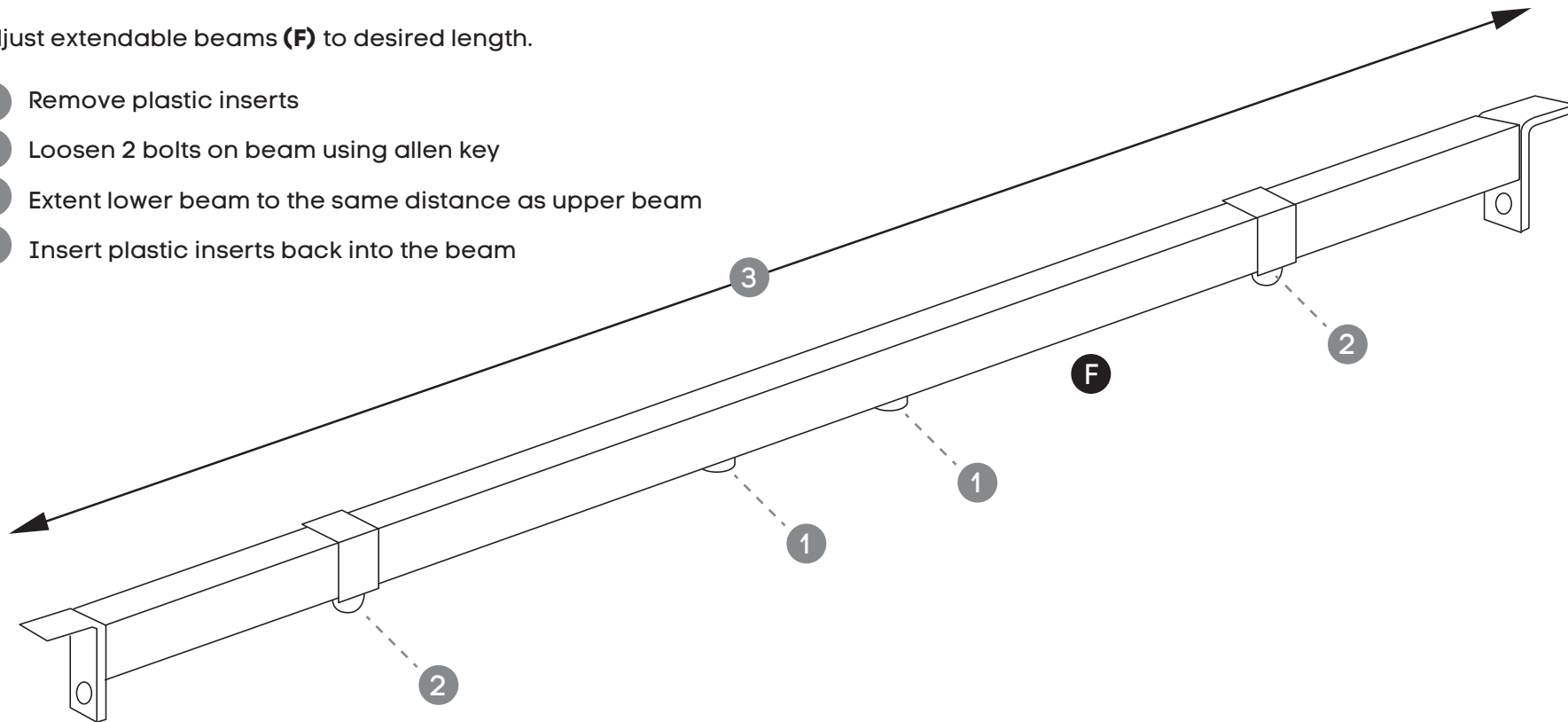

# ASSEMBLY INSTRUCTIONS

## Quadro Wood A leg Counter table Radius Corners

[www.jasonl.com.au](http://www.jasonl.com.au)

**Need help!**

Call us on  
**1300 527 665**

**jason.l**  
your office furniture mate



Sizes: 3200x1100 mm

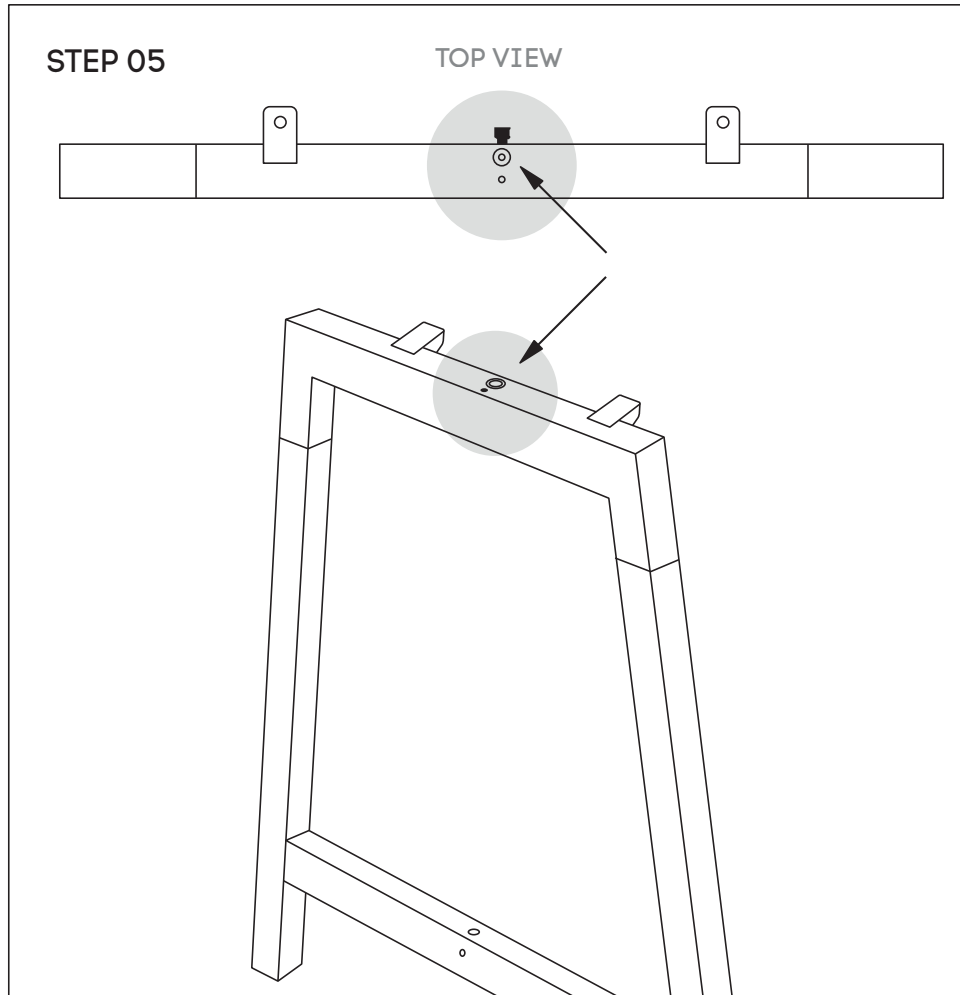
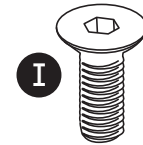

Attach Upper Beams **(E)** to legs using nut insert.  
See point attached

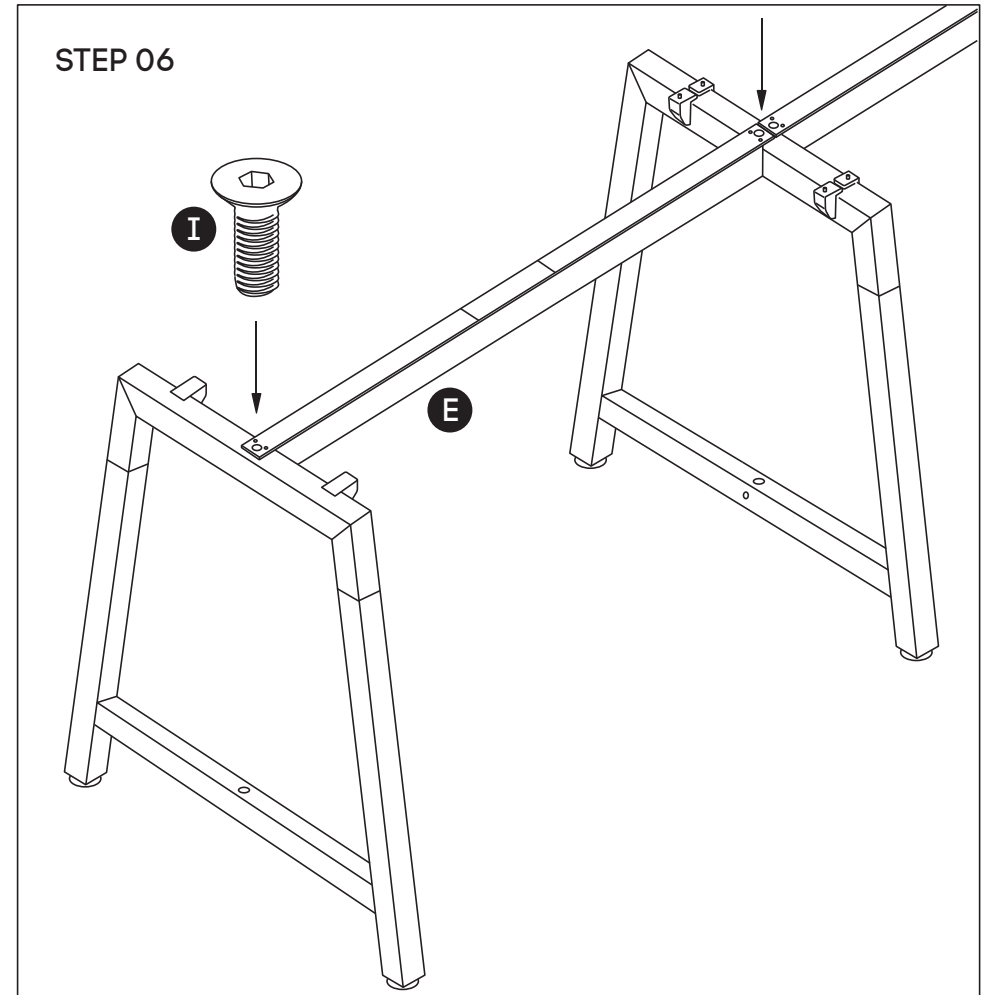

Frame looks like this. Using Allen Key, attach Upper Beams **(E)** with Sockets **(I)**.



# ASSEMBLY INSTRUCTIONS

## Quadro Wood A leg Counter table Radius Corners

[www.jasonl.com.au](http://www.jasonl.com.au)

**Need help!**

Call us on  
**1300 527 665**

**jason.l**  
your office furniture mate



Sizes: 3200x1100 mm

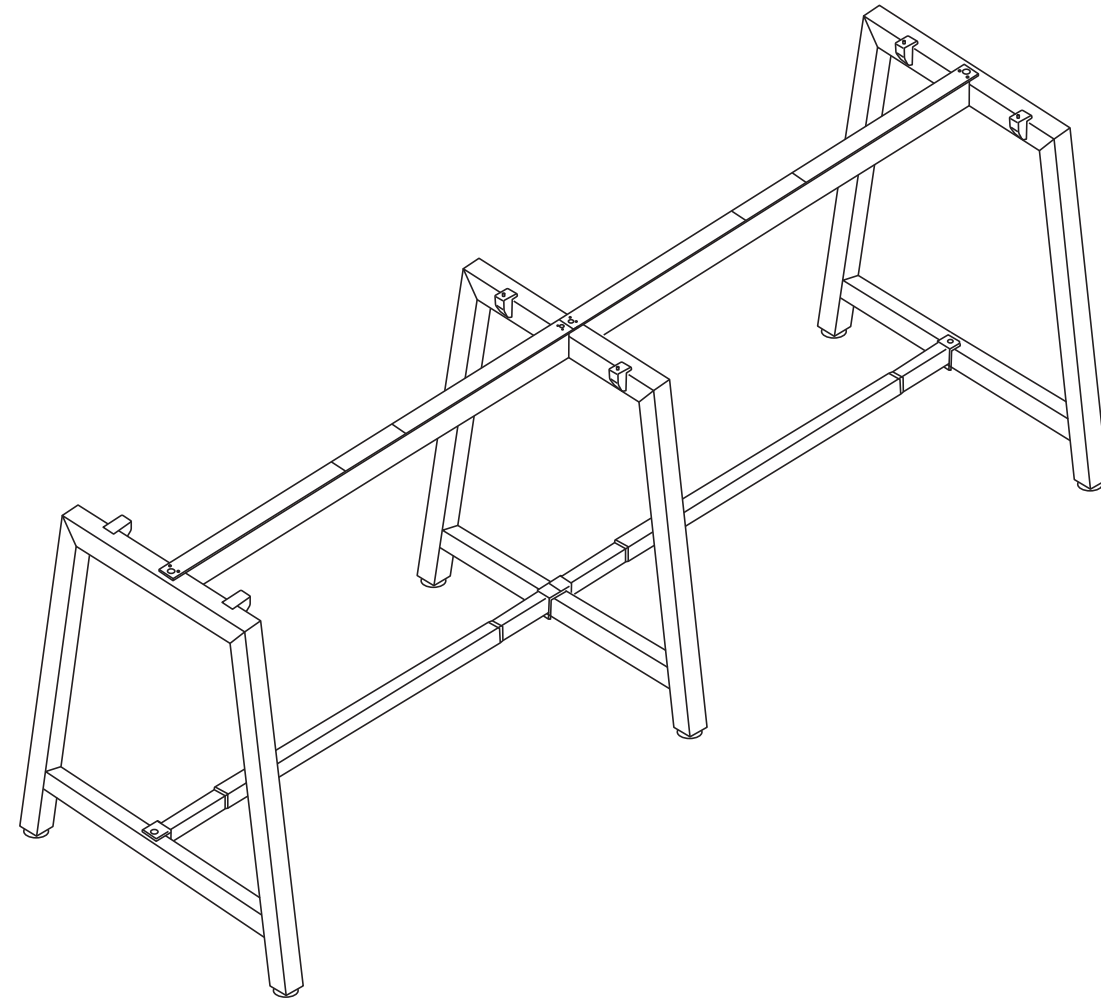
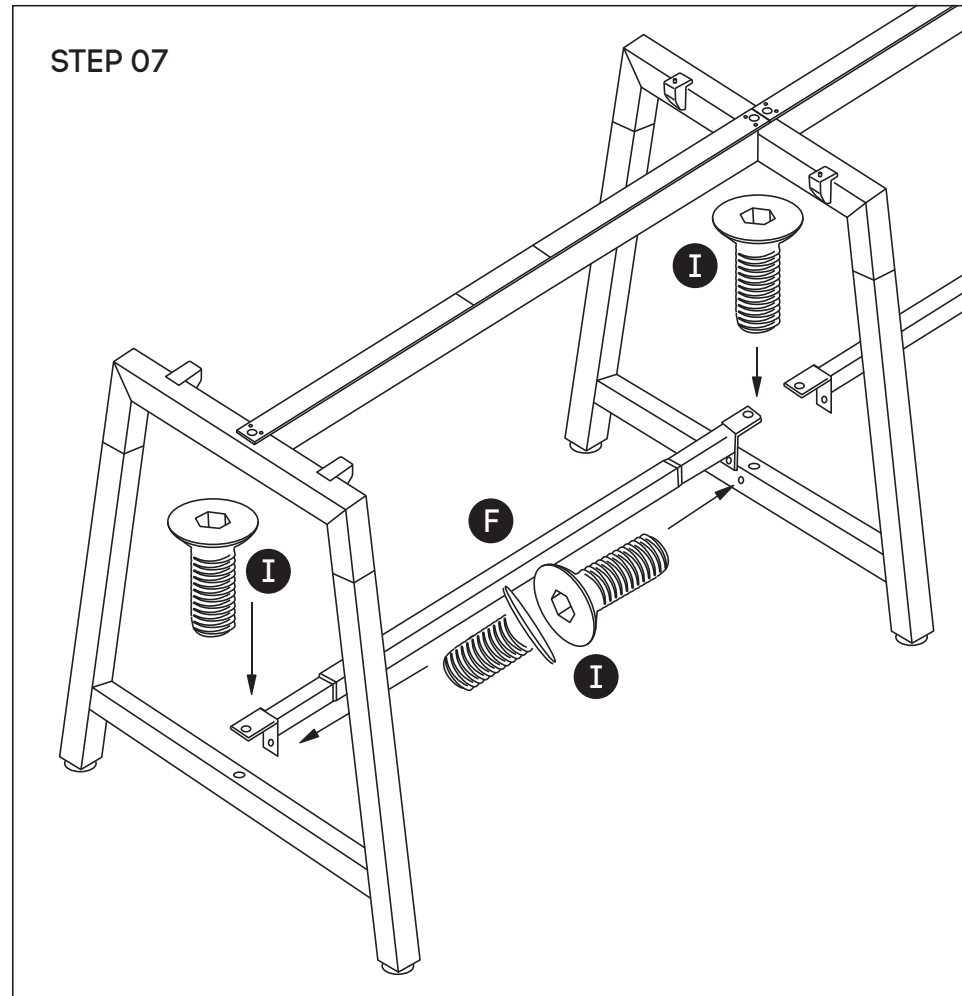

Frame looks like this. Using Allen Key. Tighen Sockets **(I)** on the Lower Beams **(F)** using Allen Key **(O)**. Insert plastic spacers to improve rigidity. Attach two Sockets **(I)** to the side of each lower side beams (as shown in the picture).

# ASSEMBLY INSTRUCTIONS

## Quadro Wood A leg Counter table Radius Corners

[www.jasonl.com.au](http://www.jasonl.com.au)

**Need help!**

Call us on  
**1300 527 665**

**jason.l**  
your office furniture mate



Sizes: 3200x1100 mm

STEP 08

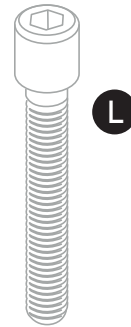
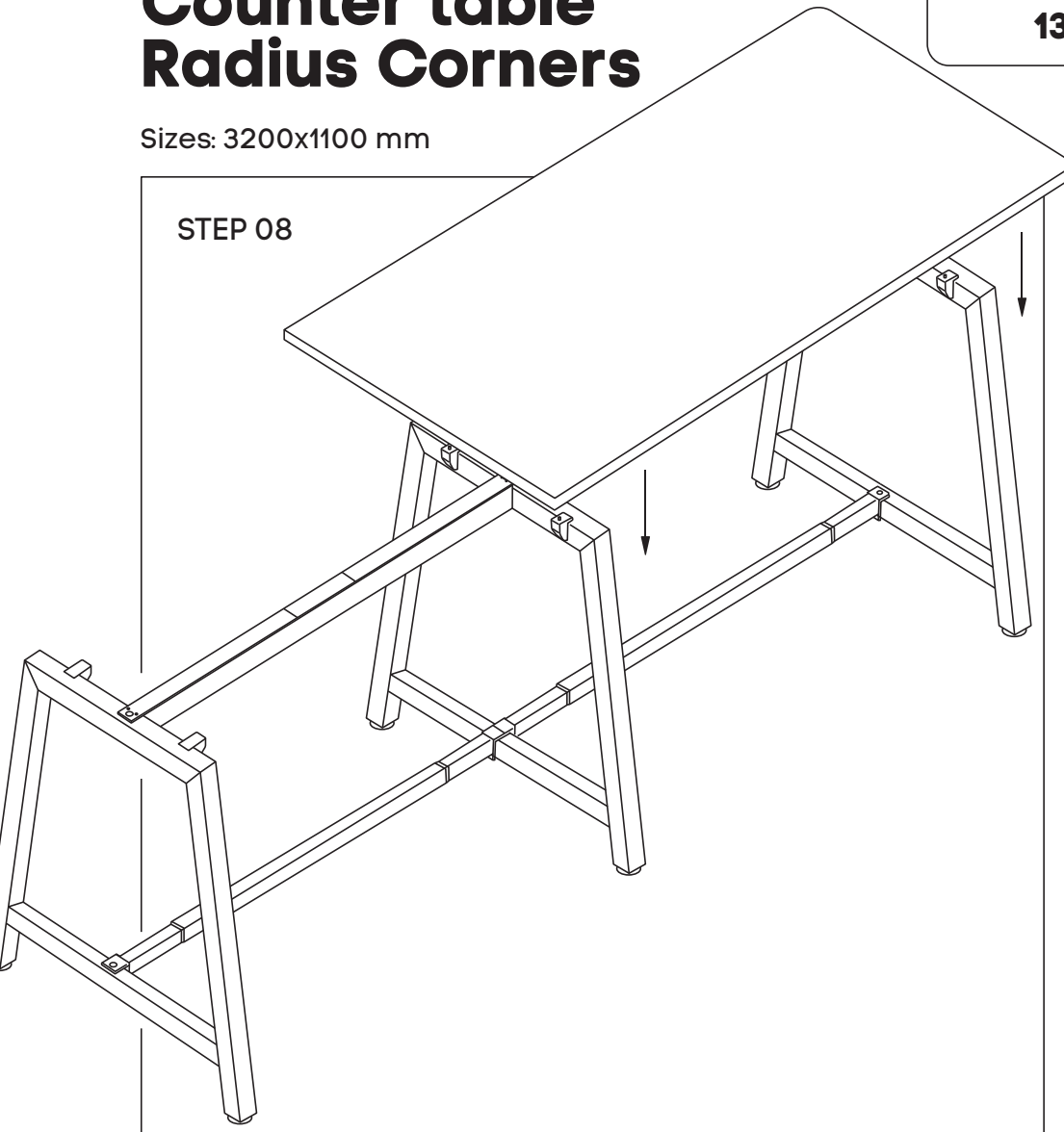
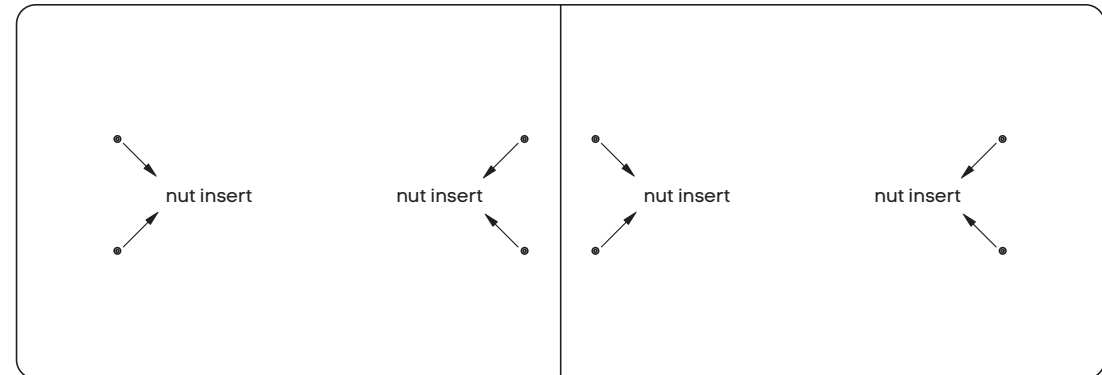

TABLE TOP  
BOTTOM VIEW



Place desktops ontop of frame. Nut inserts in top will align with plastic joiner brackets using M6x30MM (L) sockets attached top to frame.