

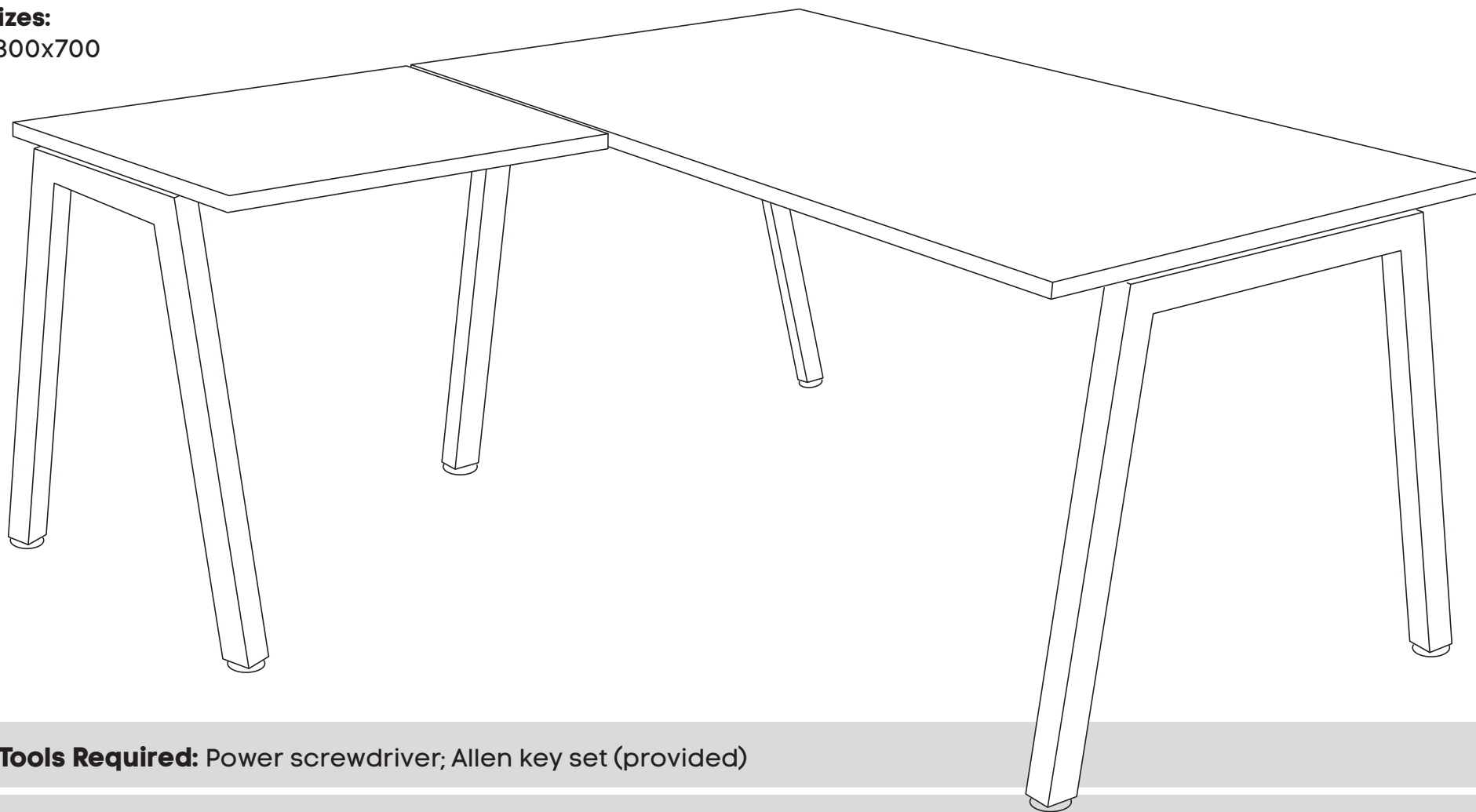

Quadro Wood A L-Shaped Desk

Sizes:
1800x700



Tools Required: Power screwdriver; Allen key set (provided)

 2 persons required for installation

Need help!

Call us on **1300 527 665**

Quadro Wood A L-Shaped Desk

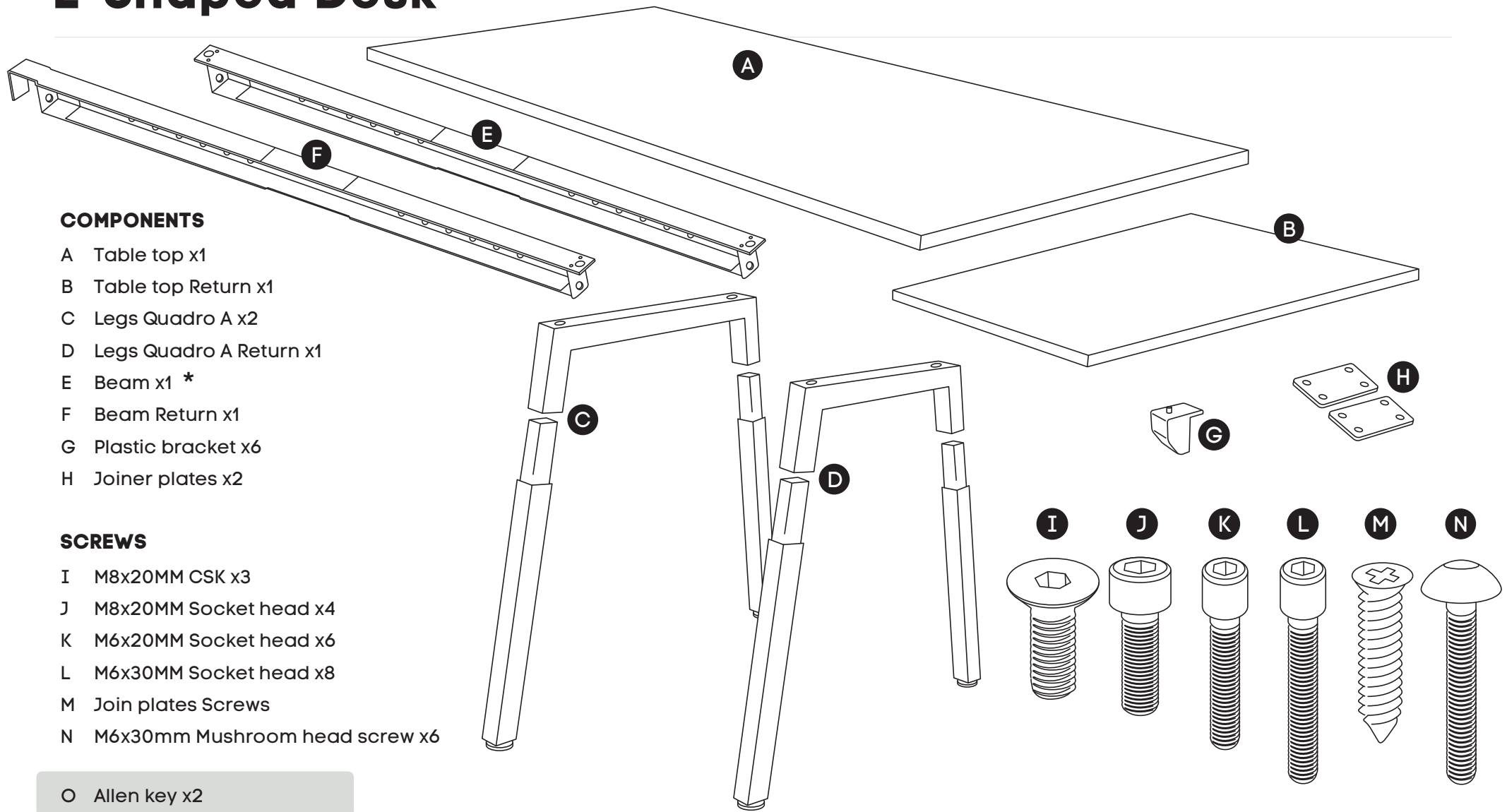

COMPONENTS

- A Table top x1
- B Table top Return x1
- C Legs Quadro A x2
- D Legs Quadro A Return x1
- E Beam x1 *
- F Beam Return x1
- G Plastic bracket x6
- H Joiner plates x2

SCREWS

- I M8x20MM CSK x3
- J M8x20MM Socket head x4
- K M6x20MM Socket head x6
- L M6x30MM Socket head x8
- M Join plates Screws
- N M6x30mm Mushroom head screw x6

O Allen key x2

* Colour of the beam is always black, regardless desk frame colour.

Need help!

Call us on **1300 527 665**

Quadro Wood A L-Shaped Desk

STEP 01

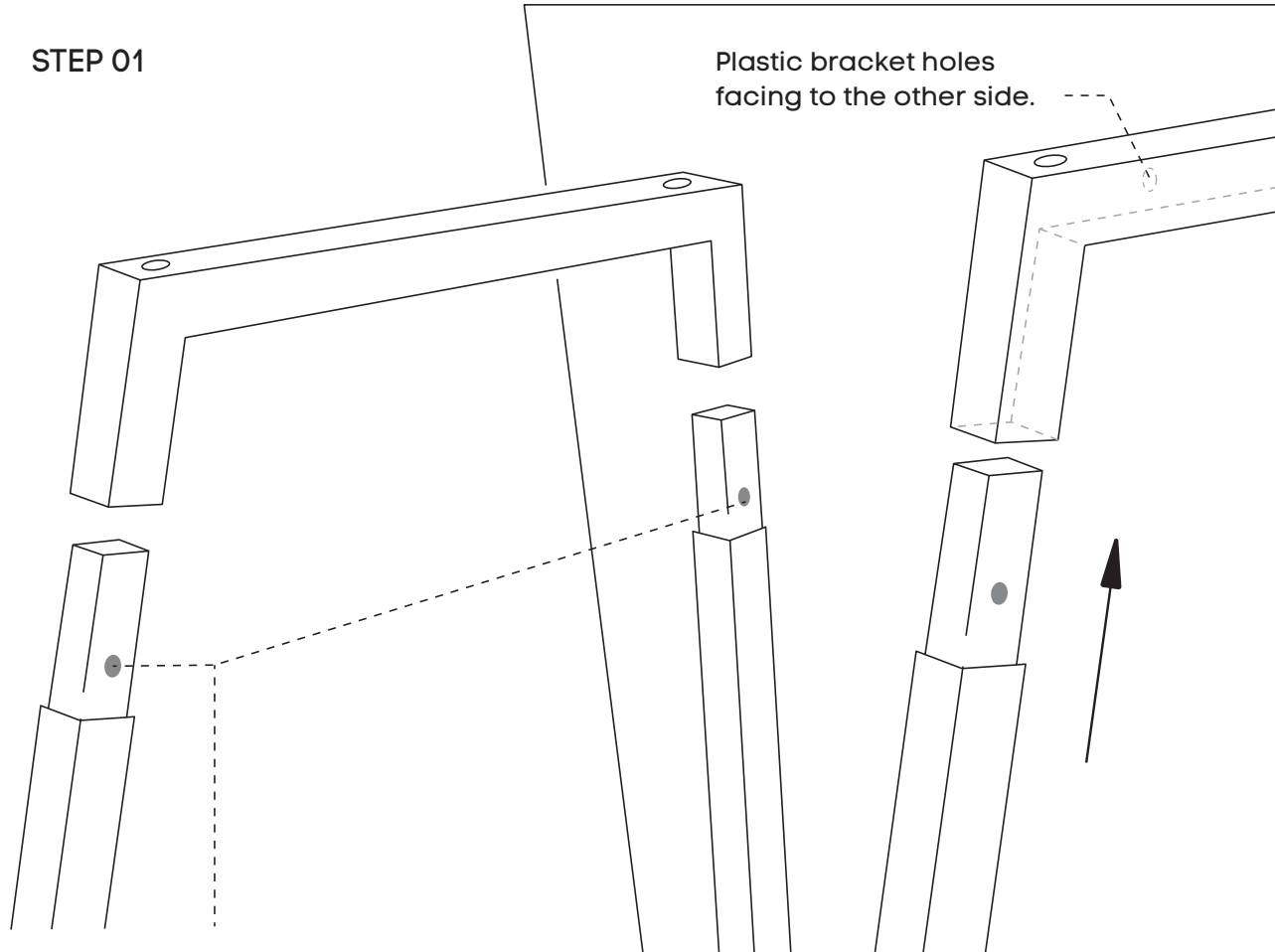

You will notice two colored stickers located on each leg.

Both legs must have the colour sticker facing away from where the plastic brackets are inserted.

STEP 02

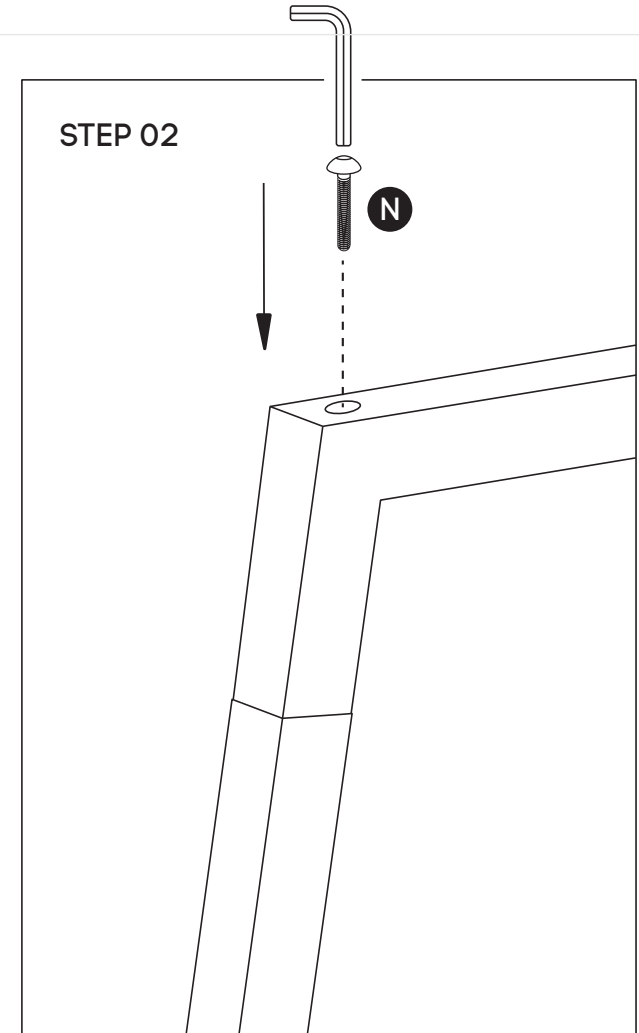

Insert the bottom of the legs as shown in the illustration. Using Allen Key provided, attach Mushroom Head Screw (N) - for all legs.

Need help!

Call us on **1300 527 665**

Quadro Square L-Shaped Desk

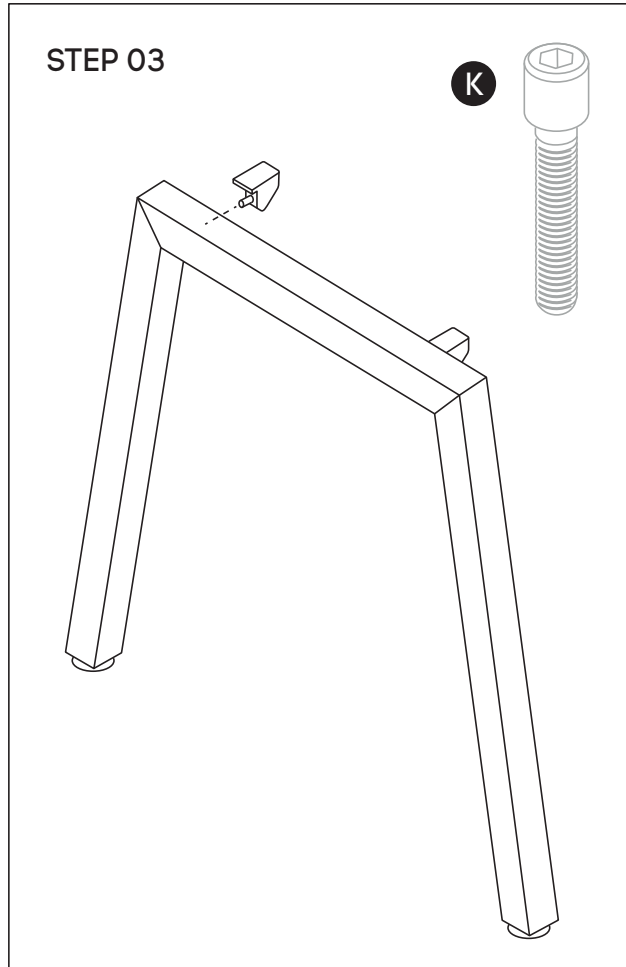

Using Allen Key provided, attach 2 plastic brackets per leg (**G**) (as per picture above) using M6x20MM (**K**) Socket head screw

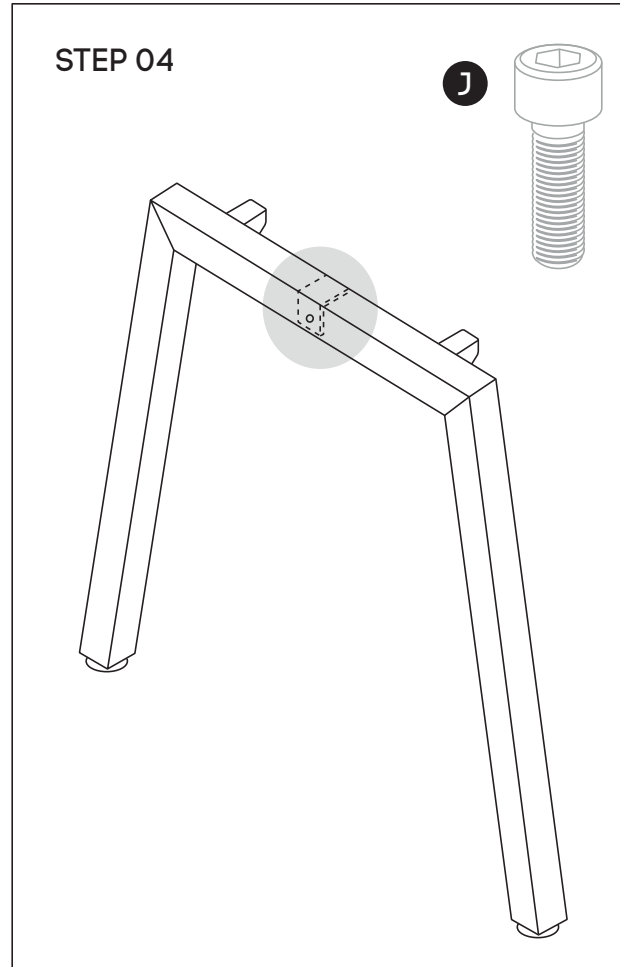

Using Allen Key provided, attach M8x20MM Socket head (**J**) - screw socket half way into leg for both legs (**C**)

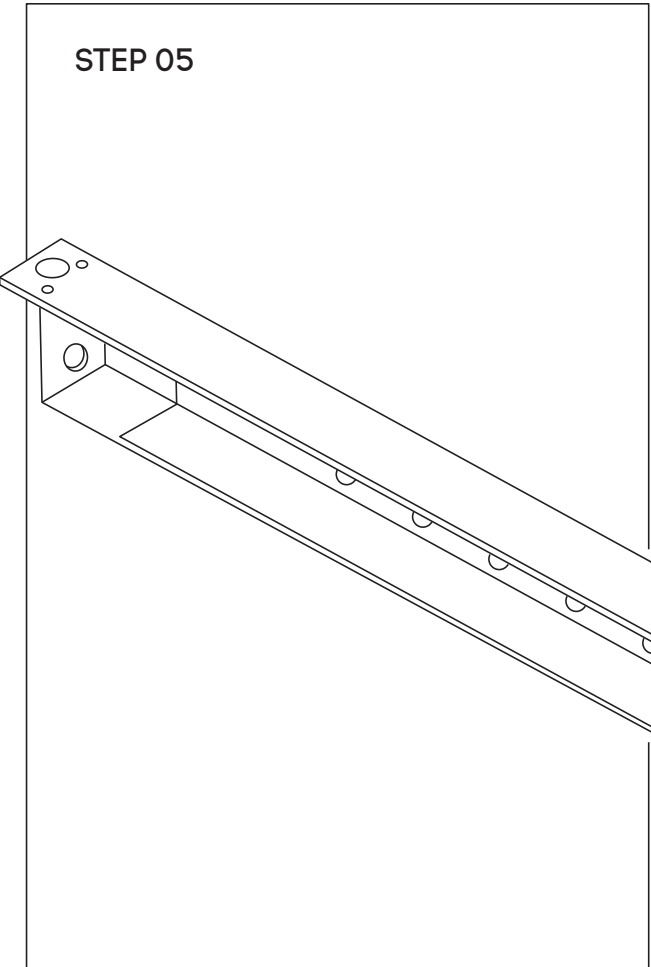

Use fixed beam (**E**) and secure beam using screws provided.

Quadro Wood A L-Shaped Desk

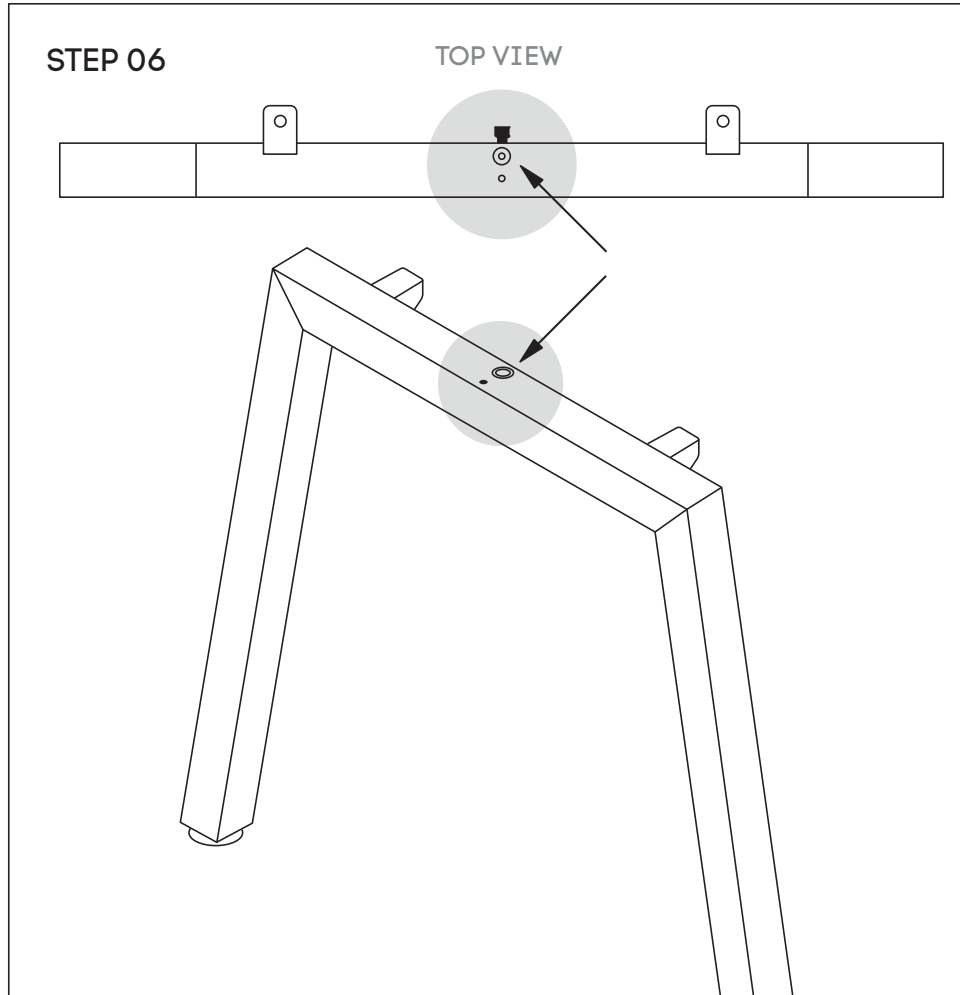

Attach beam **(E)** to legs **(C)** using nut insert in legs.
See point attached

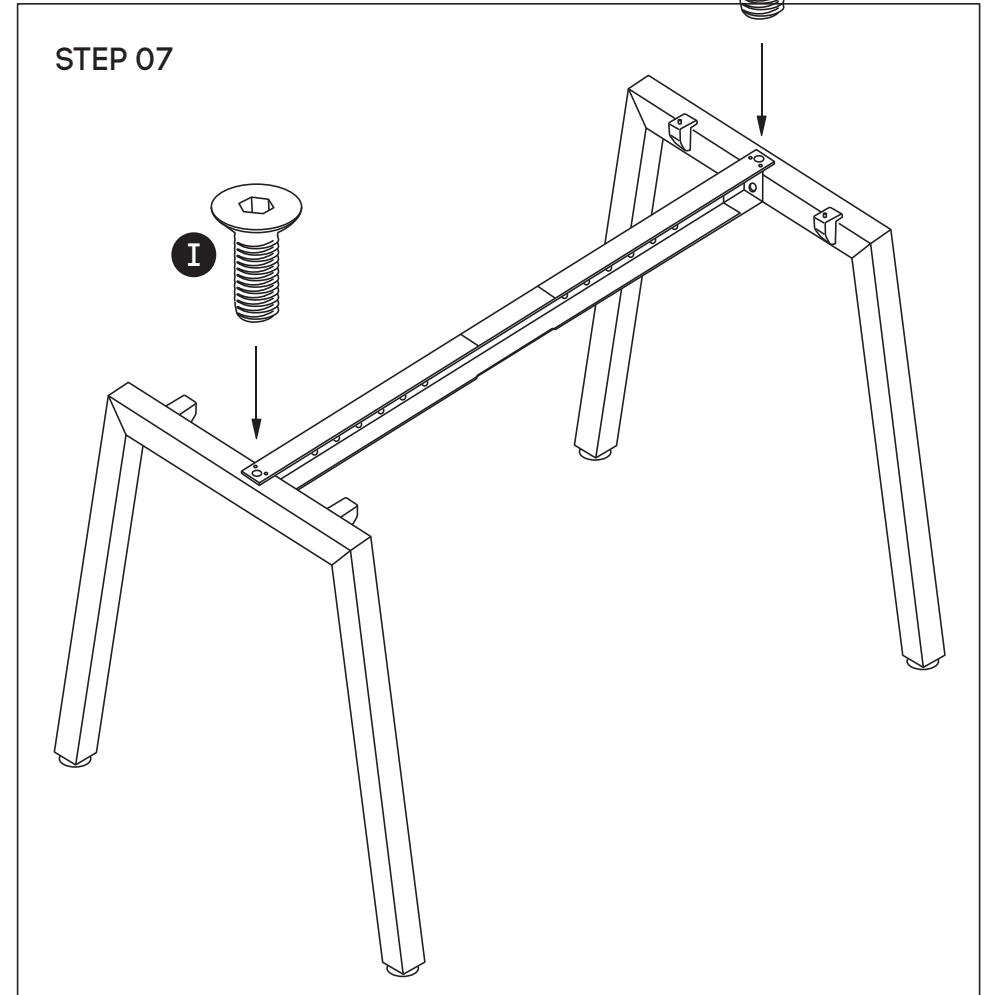

Frame looks like this. Using Allen Key, attach beam **(E)** with Socket **(I)**

Need help!

Call us on **1300 527 665**

Quadro Wood A L-Shaped Desk

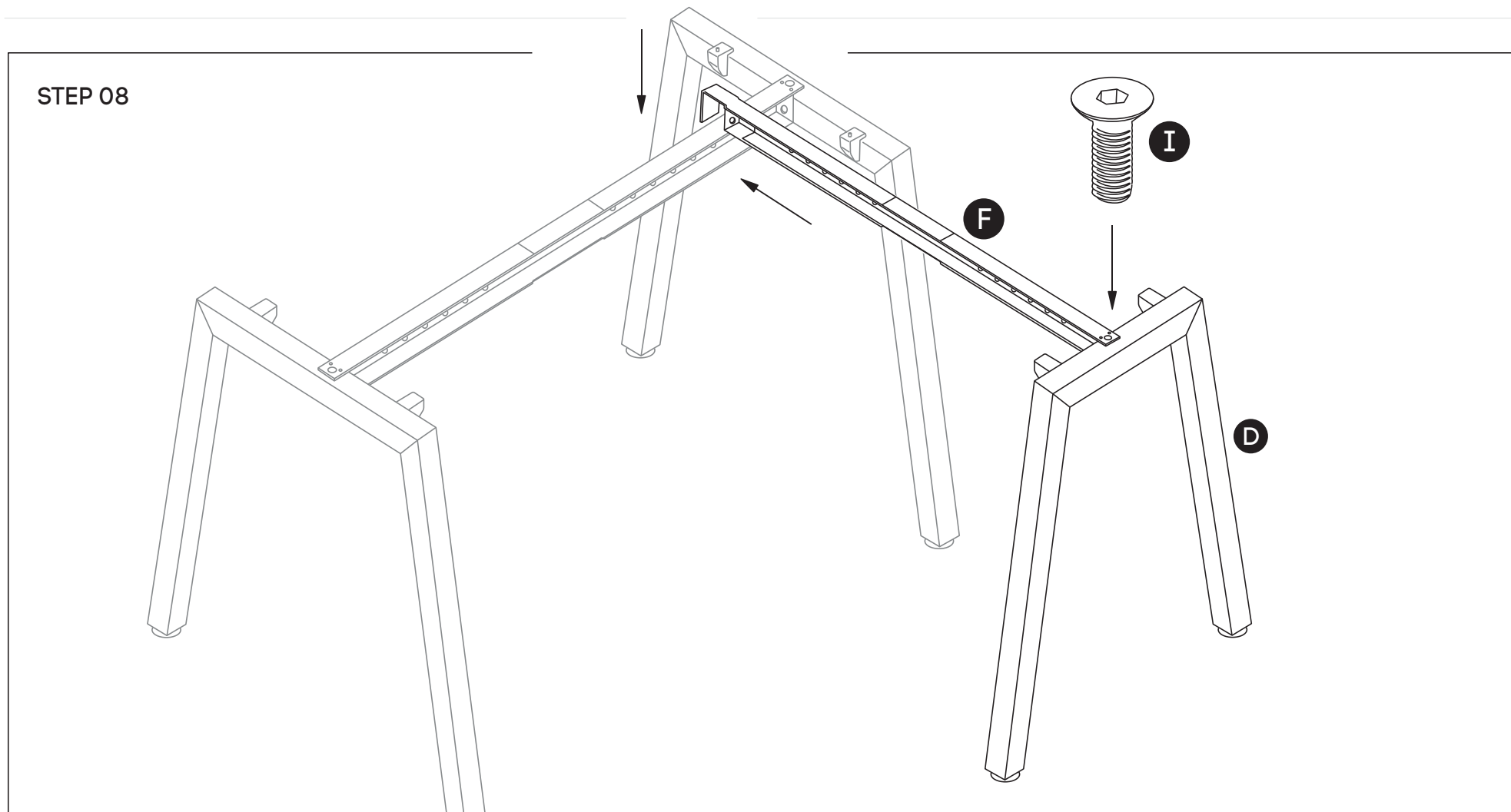

Now attach the return beam **(F)** to return leg **(D)** using nut insert in legs. See point attached.
Then, connect the hook of the return beam to the beam of the main structure.

Need help!

Call us on **1300 527 665**

Quadro Wood A L-Shaped Desk

STEP 09

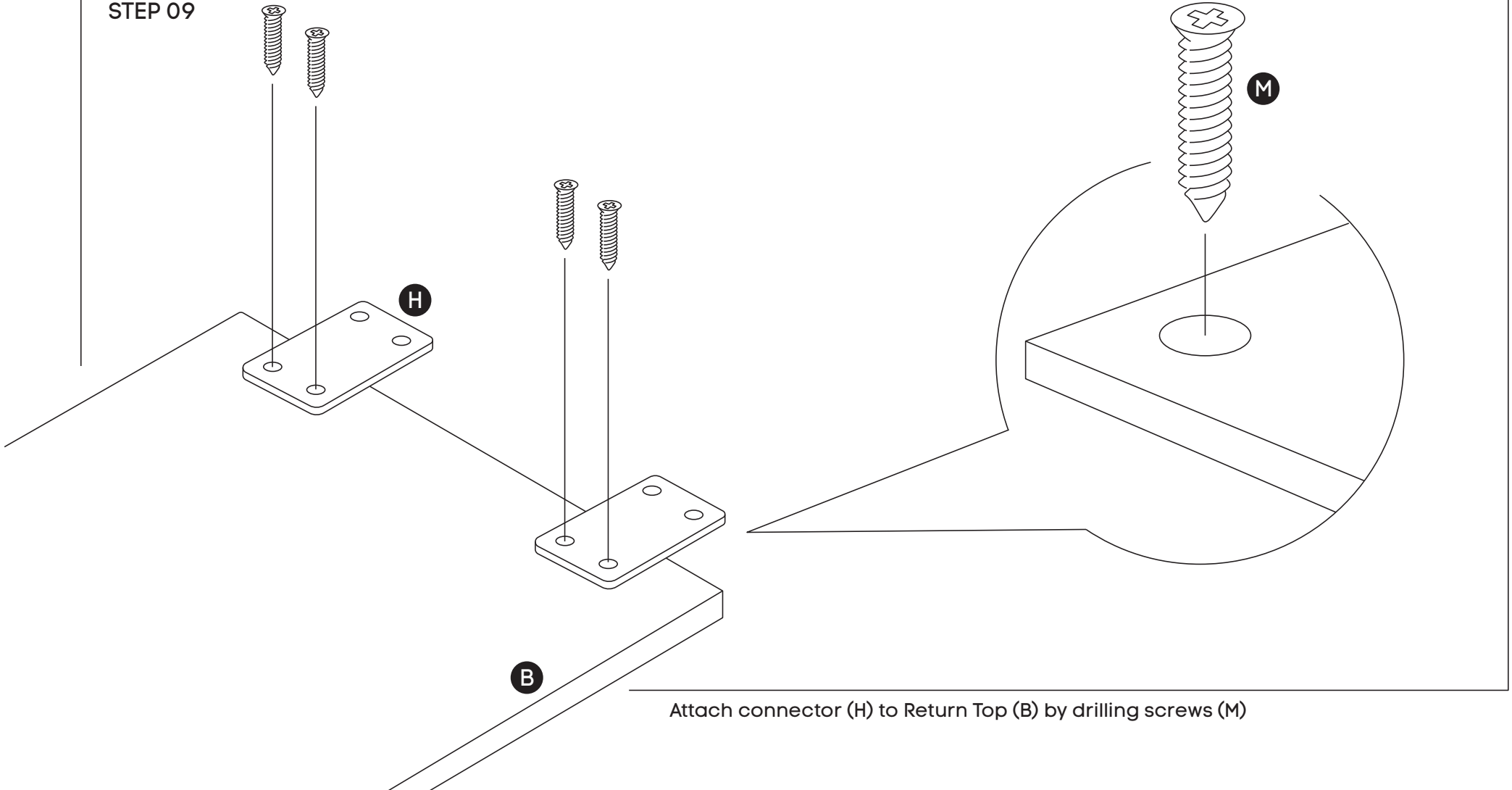

Attach connector (H) to Return Top (B) by drilling screws (M)

Need help!

Call us on **1300 527 665**

Quadro Wood A L-Shaped Desk

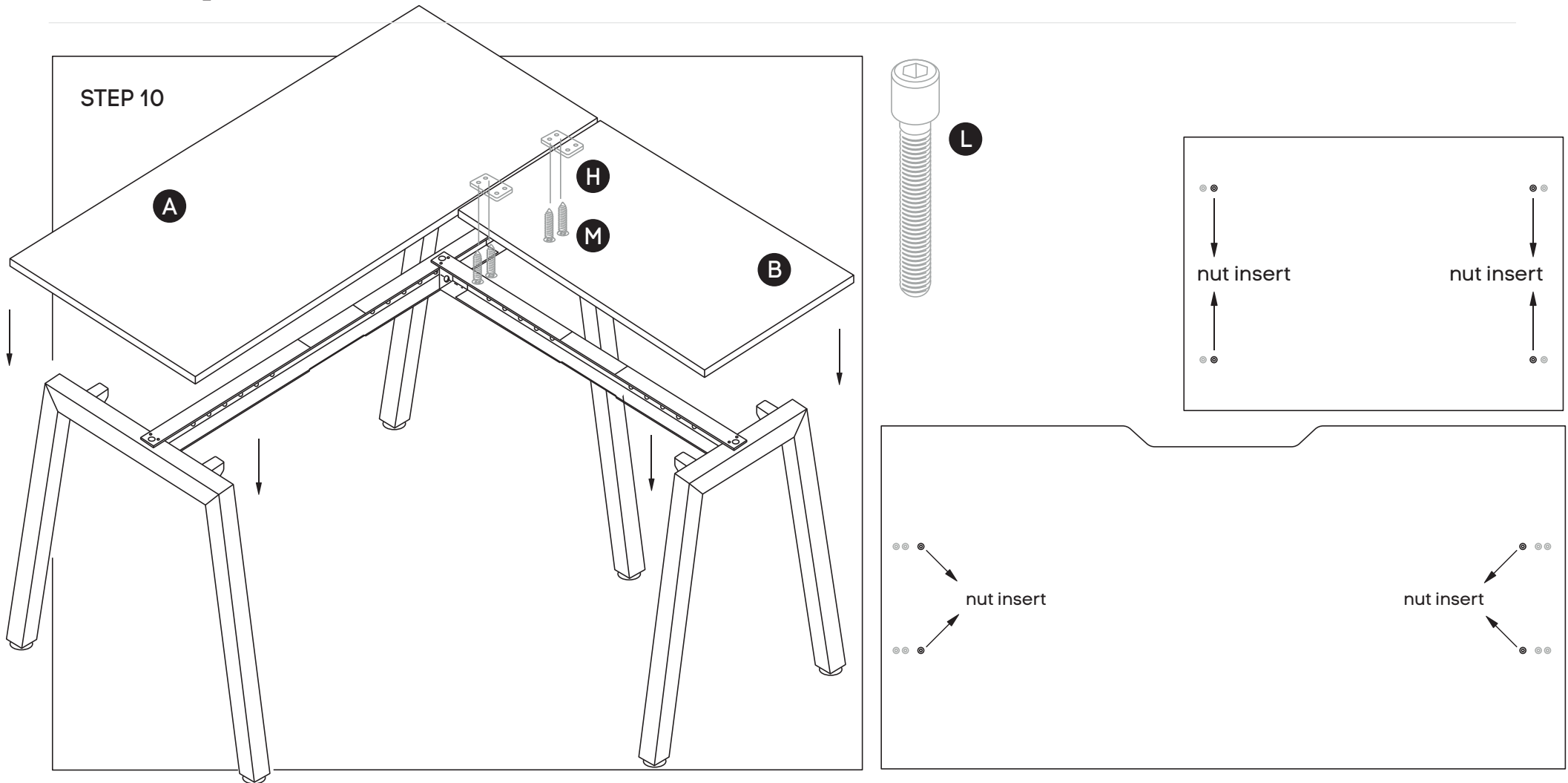

Place table top **(A)** on top of frame - with cutout at the back of the desk. Using nut inserts in the desk, use M6x30mm socket **(L)** and attach desktop to the frame. Using nut inserts in the desktop, use M6x30mm socket **(L)** and attach desktop **(B)** to the frame. Once desktop are attached and secure to the frame, use woods screws and secure joiner plates to the underside of desktop A.

TABLE TOP
BOTTOM VIEW

Need help! Call us on **1300 527 665**