

ASSEMBLY INSTRUCTIONS

Quadro Square leg 2 person corner workstations T configuration

www.jasonl.com.au

Need help!

Call us on
1300 527 665

jason.l
your office furniture mate



Sizes: 1400Lx1800W , 1600Lx1800W , 1800Lx1800W mm

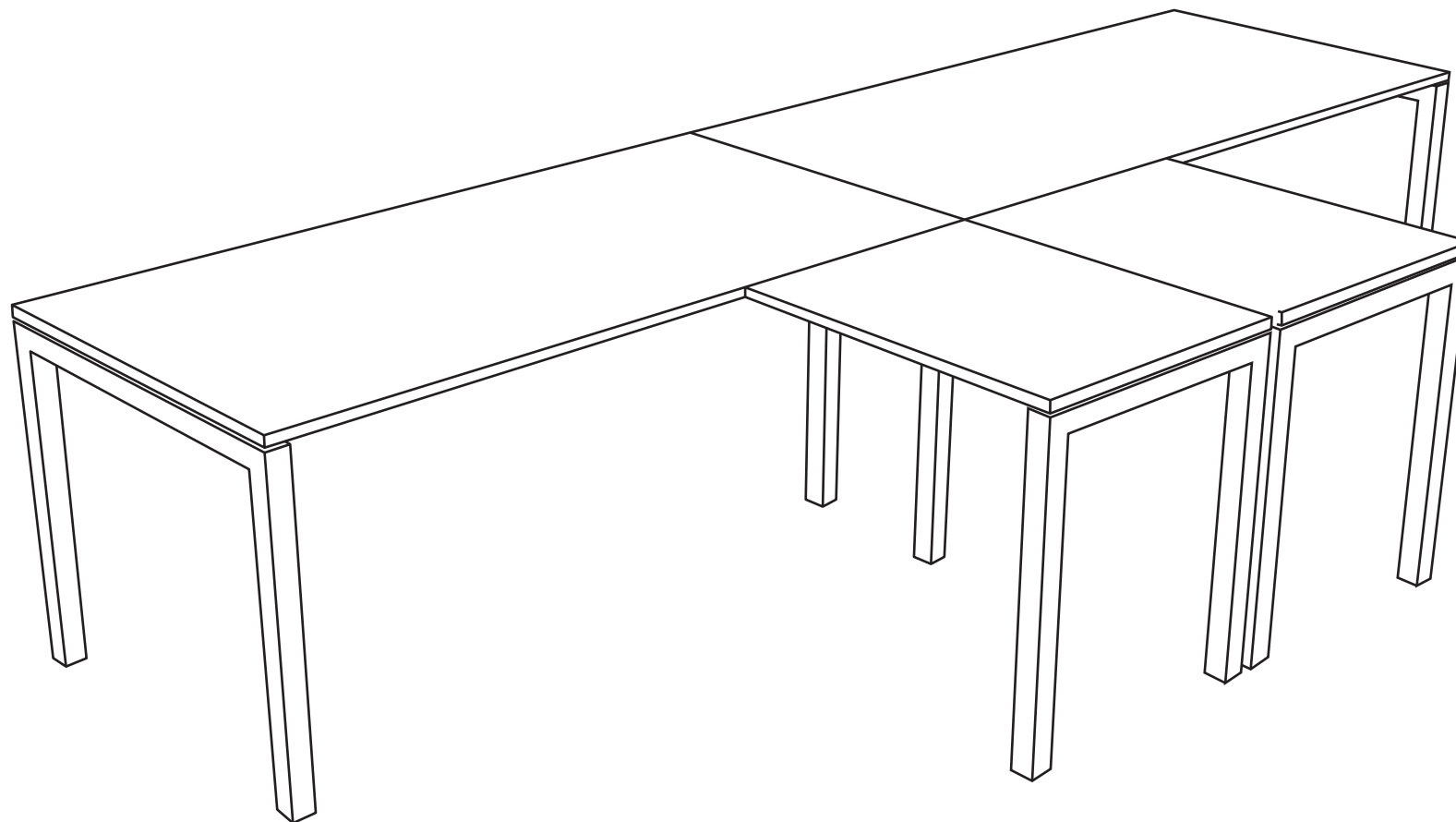

Tools Required: Power screwdriver; Allen key set (provided)

 2 persons required for installation

ASSEMBLY INSTRUCTIONS

Quadro Square leg 2 person corner workstations T configuration

www.jasonl.com.au

Need help!
Call us on
1300 527 665

jason.l
your office furniture mate



Sizes: 1400Lx1800W , 1600Lx1800W , 1800Lx1800W mm

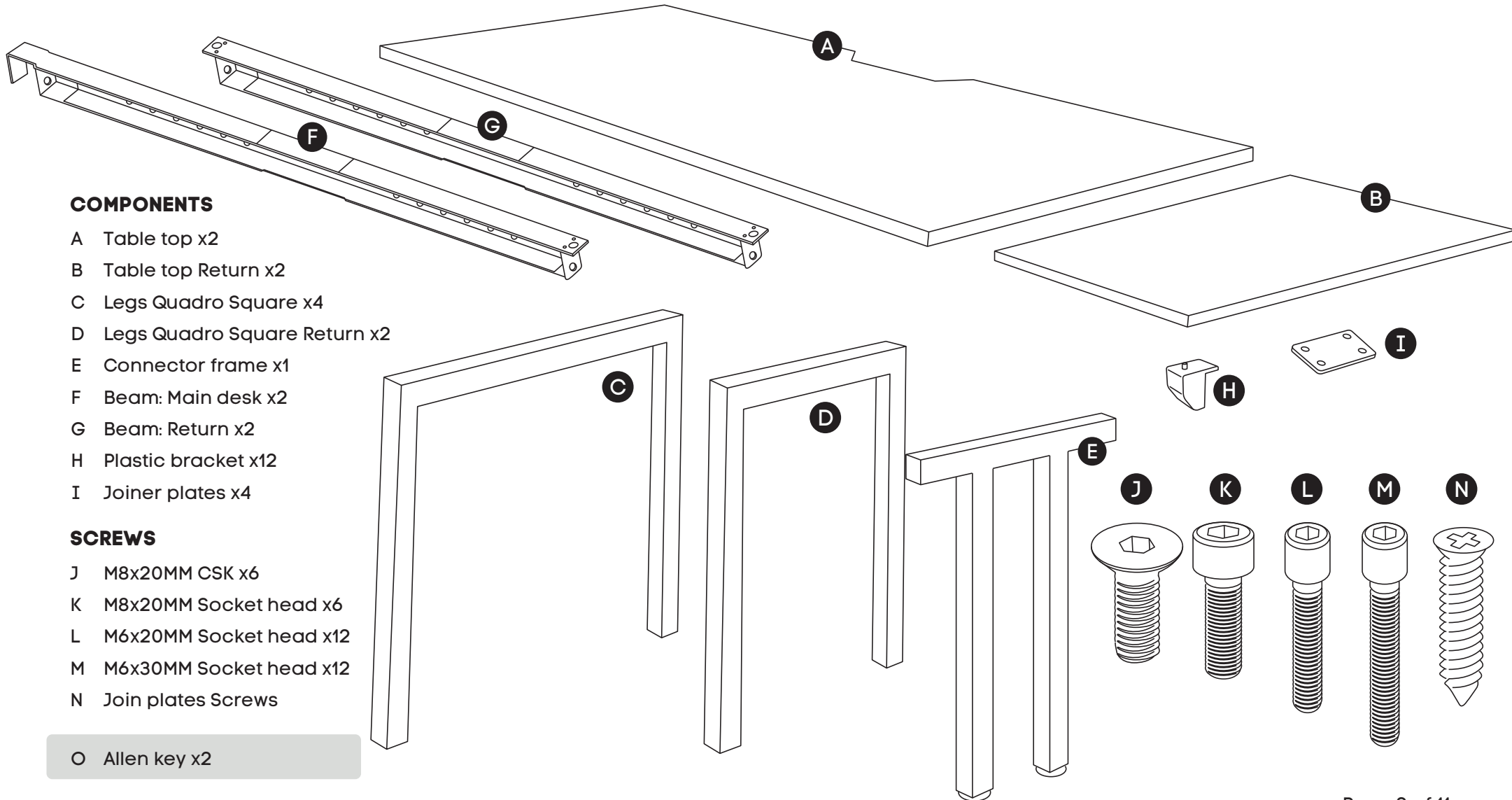

COMPONENTS

- A Table top x2
- B Table top Return x2
- C Legs Quadro Square x4
- D Legs Quadro Square Return x2
- E Connector frame x1
- F Beam: Main desk x2
- G Beam: Return x2
- H Plastic bracket x12
- I Joiner plates x4

SCREWS

- J M8x20MM CSK x6
- K M8x20MM Socket head x6
- L M6x20MM Socket head x12
- M M6x30MM Socket head x12
- N Join plates Screws

○ Allen key x2

ASSEMBLY INSTRUCTIONS

Quadro Square leg 2 person corner workstations T configuration

www.jasonl.com.au

Need help!
Call us on
1300 527 665

jason.l
your office furniture mate



Sizes: 1400Lx1800W , 1600Lx1800W , 1800Lx1800W mm

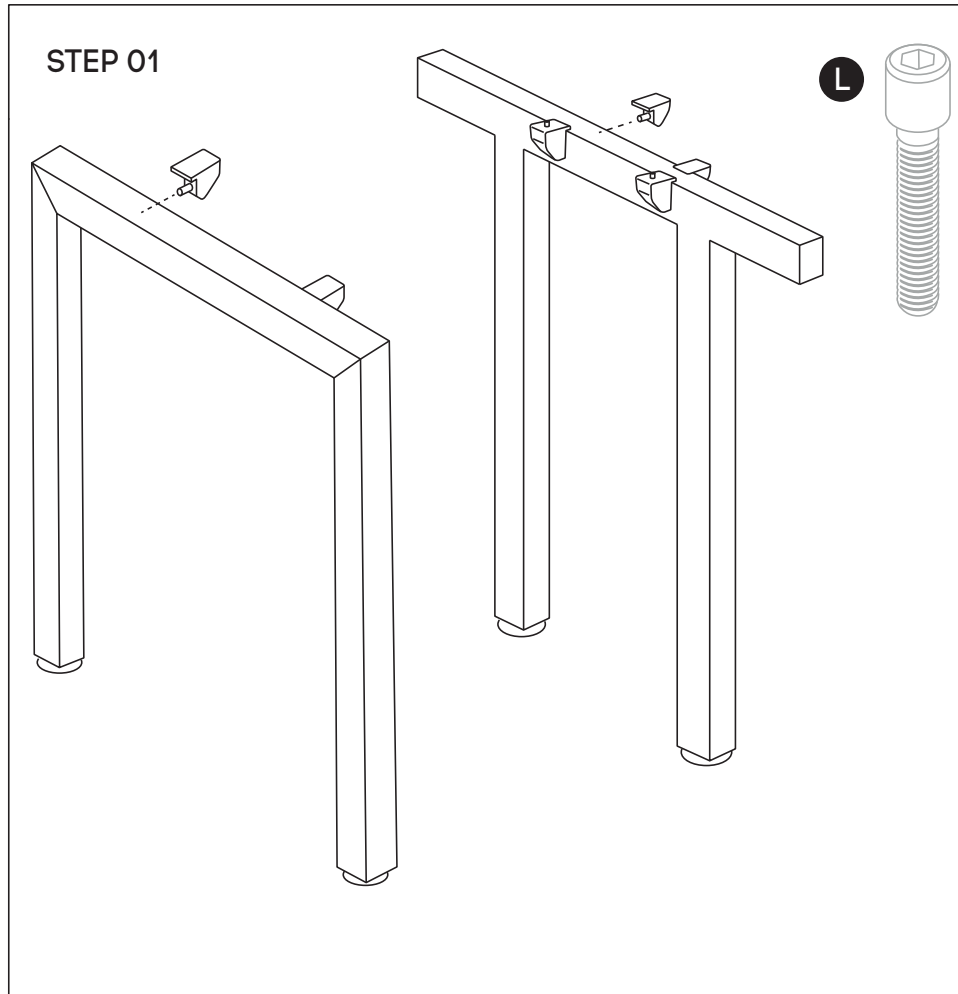

Using Allen Key provided, attach 2 plastic brackets per leg **(C)(D)** (as per picture above) using M6x20MM **(L)** Socket head screw. Do the same with Connector frame **(E)**.

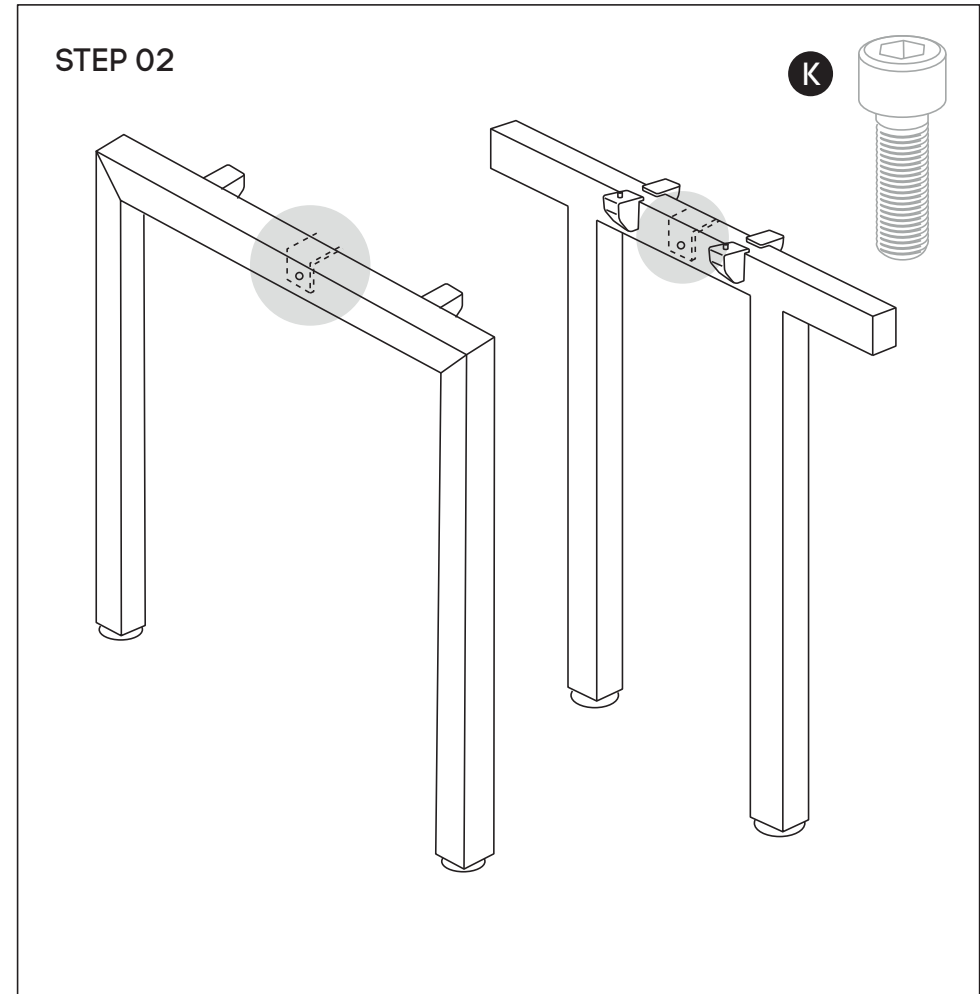

Using Allen Key provided, attach M8x20MM Socket head **(K)**-screw socket half way into leg for both legs **(C)** and into Connector frame **(E)**.

ASSEMBLY INSTRUCTIONS

Quadro Square leg 2 person corner workstations T configuration

www.jasonl.com.au

Need help!
Call us on
1300 527 665

jason.l
your office furniture mate



Sizes: 1400Lx1800W , 1600Lx1800W , 1800Lx1800W mm

STEP 03

Adjust extendable beam **(F)** to desired length using markers and secure beam at that length using screws provided

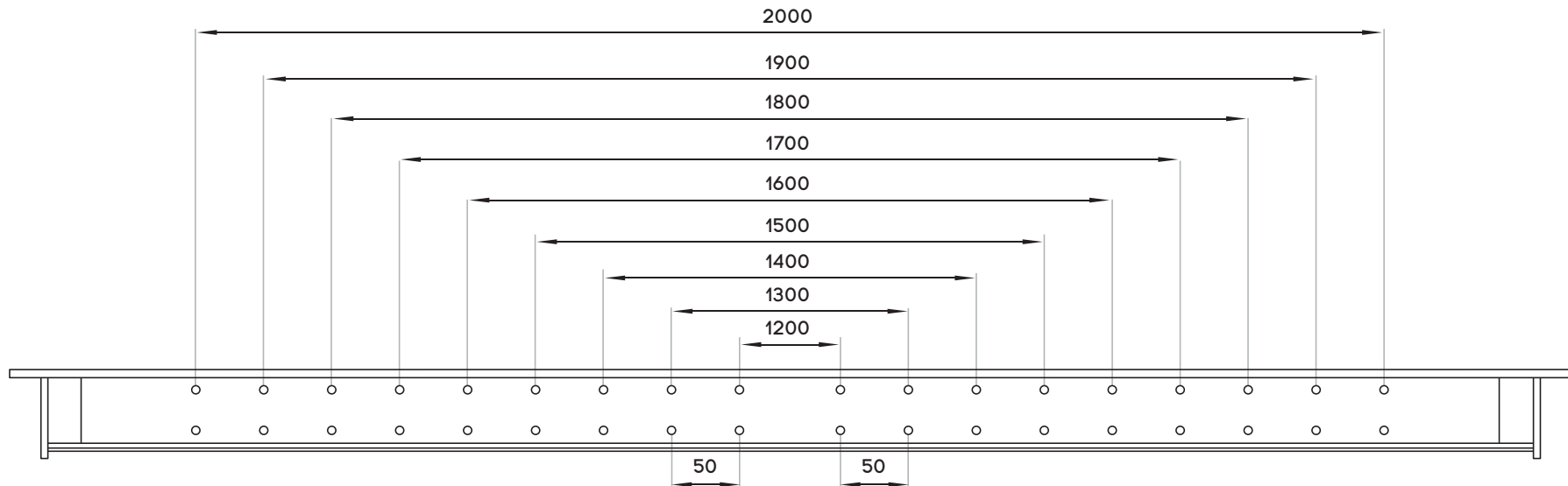
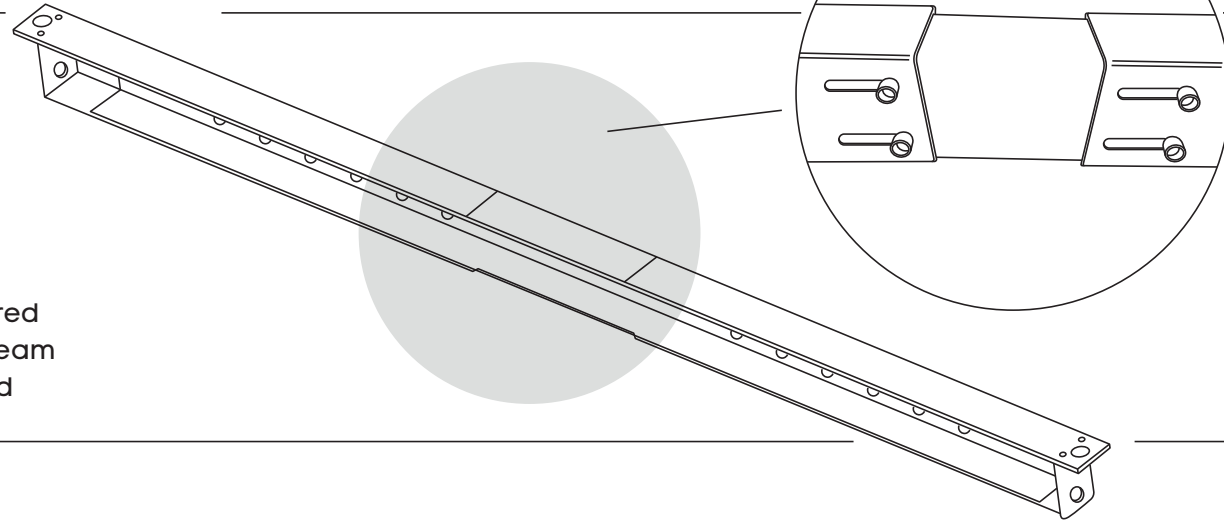

ASSEMBLY INSTRUCTIONS

Quadro Square leg 2 person corner workstations T configuration

www.jasonl.com.au

Need help!
Call us on
1300 527 665

jason.l
your office furniture mate



Sizes: 1400Lx1800W , 1600Lx1800W , 1800Lx1800W mm

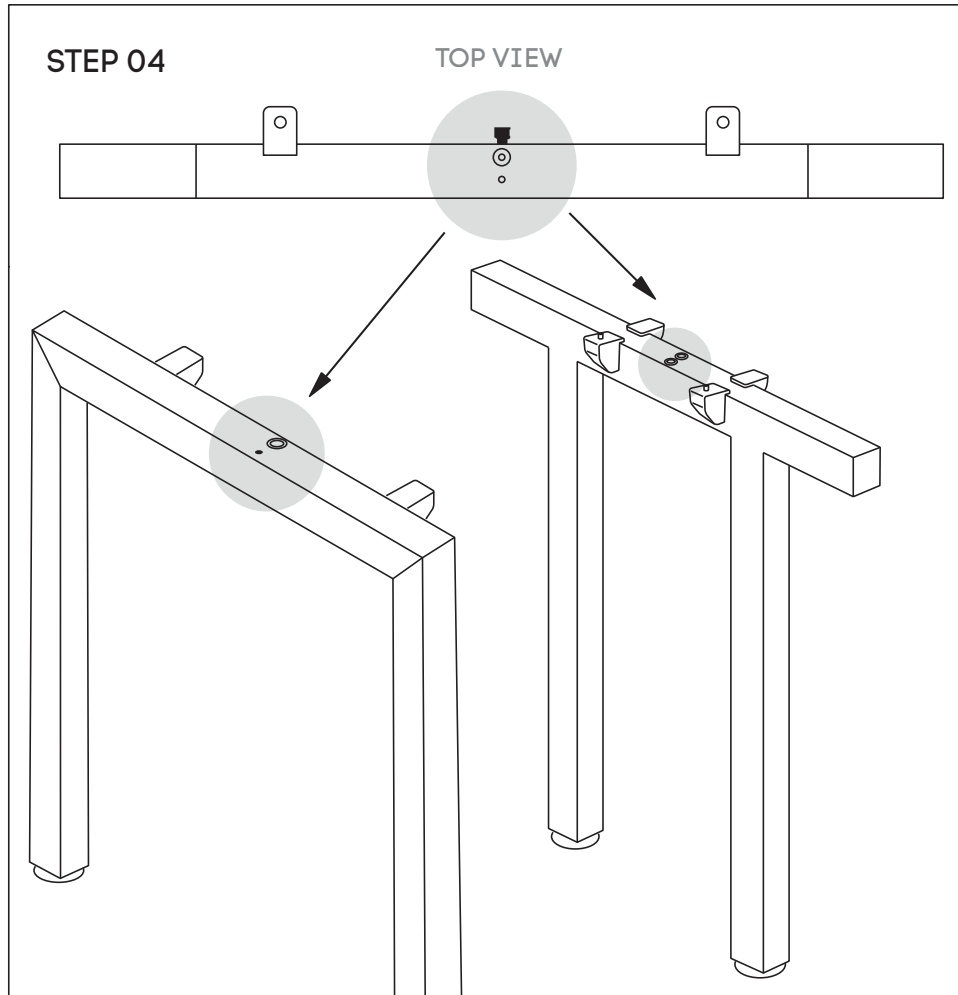

Attach beam **(F)** to legs **(C)** and Connector frame **(E)** using nut insert in legs. See point attached

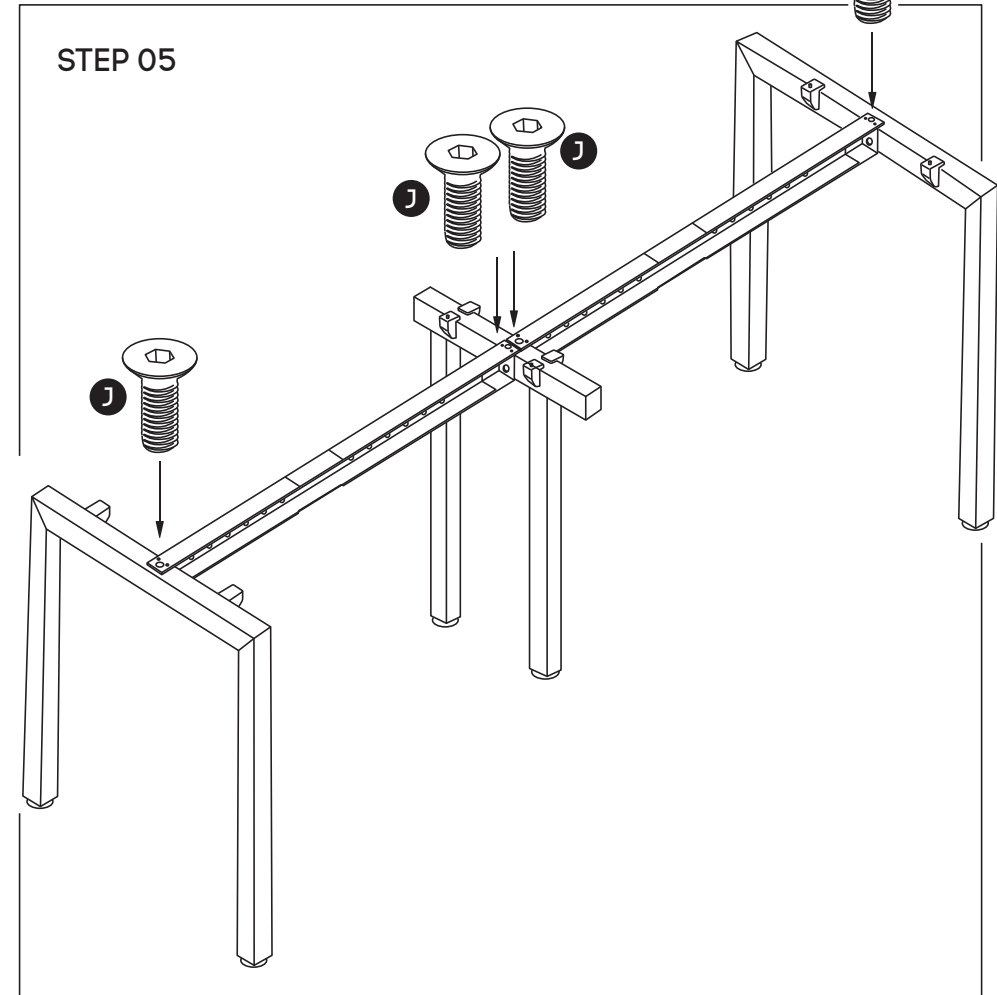

Frame looks like this. Using Allen Key, attach beam **(F)** with Socket **(J)**

ASSEMBLY INSTRUCTIONS

Quadro Square leg 2 person corner workstations T configuration

www.jasonl.com.au

Need help!
Call us on
1300 527 665

jason.l
your office furniture mate



Sizes: 1400Lx1800W , 1600Lx1800W , 1800Lx1800W mm

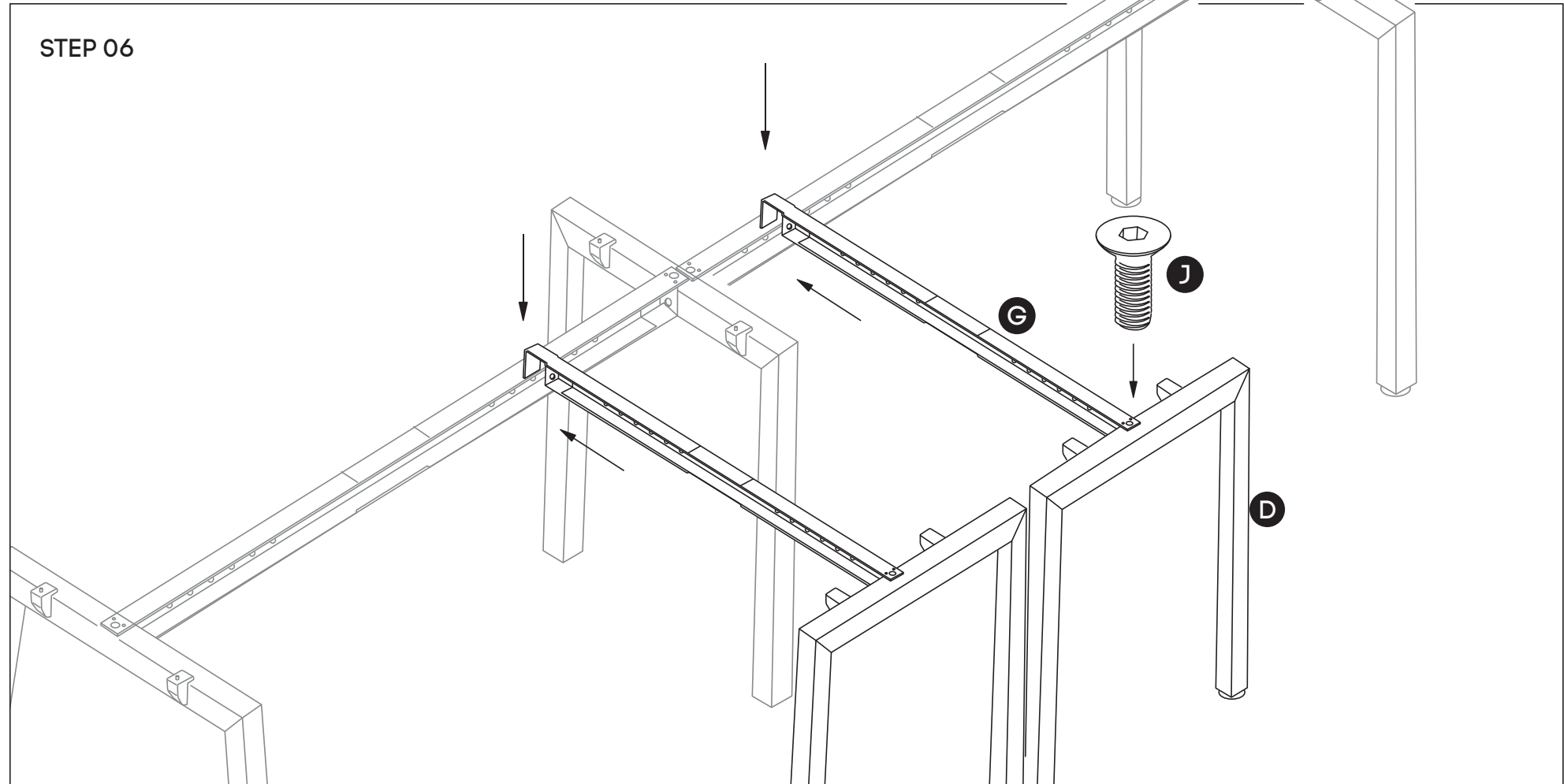

Now attach the return beams (**G**) to return legs (**D**) using nut insert in legs. See point attached.
Then, connect the hook of the return beam to the beam of the main structure.

ASSEMBLY INSTRUCTIONS

Quadro Square leg 2 person corner workstations T configuration

www.jasonl.com.au

Need help!
Call us on
1300 527 665

jason.l
your office furniture mate



Sizes: 1400Lx1800W , 1600Lx1800W , 1800Lx1800W mm

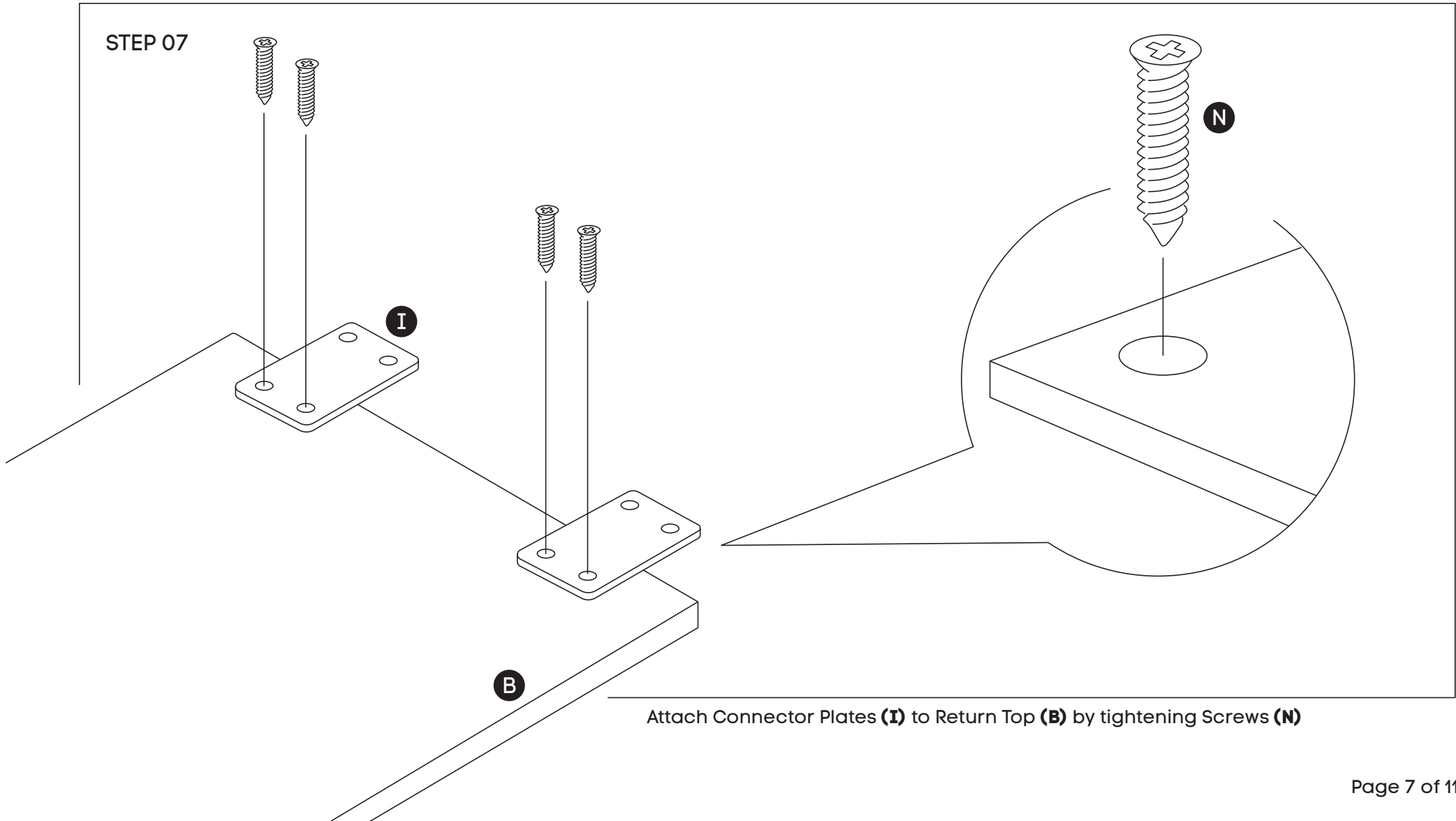

ASSEMBLY INSTRUCTIONS

Quadro Square leg 2 person corner workstations

T configuration

www.jasonl.com.au

Need help!
Call us on
1300 527 665

jason.l
your office furniture mate



Sizes: 1400Lx1800W , 1600Lx1800W , 1800Lx1800W mm

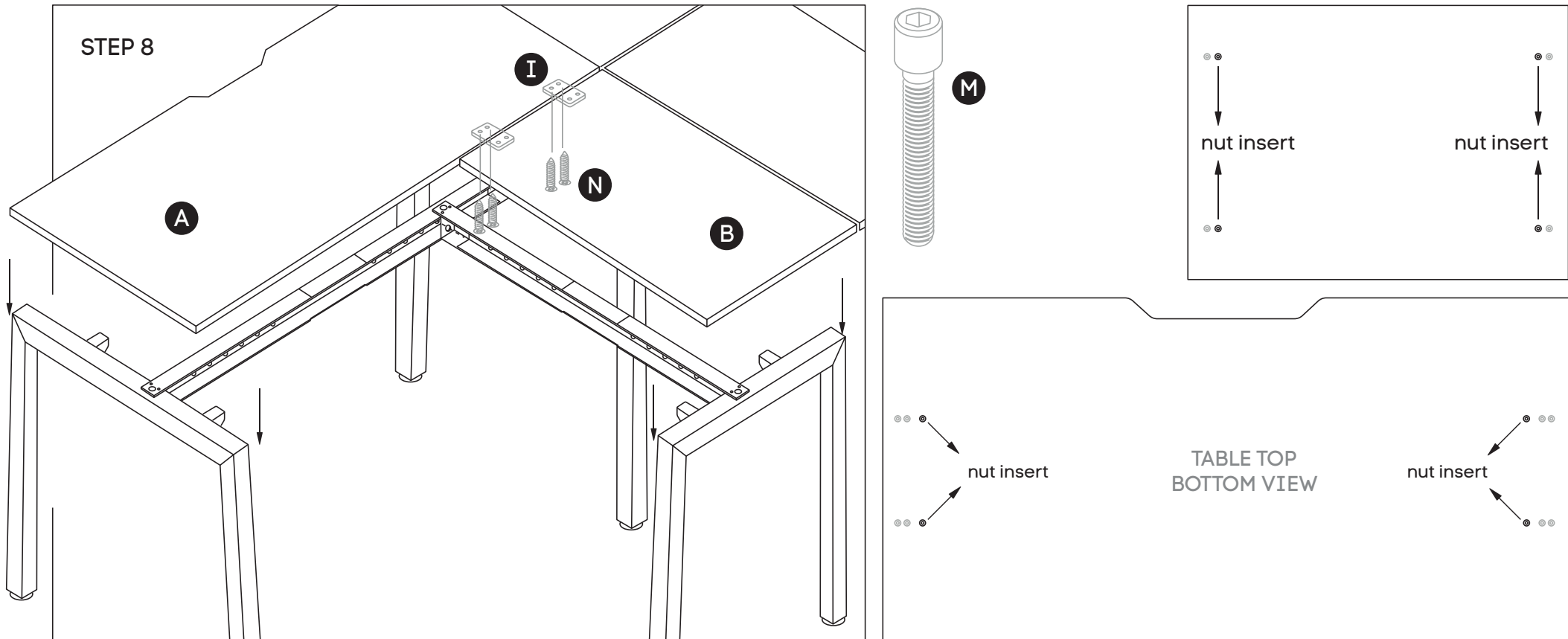

- Place table tops **(A)** on top of frame - with cutout at the back of the desk.
- Using nut inserts in the desktop, use M6x30mm socket **(M)** and attach desktop to the frame.
- Using nut inserts in the desktop, use M6x30mm socket **(M)** and attach return desktops **(B)** to the frame.
- Once desktop are attached and secure to the frame, use woods screws **(N)** and secure joiner plates **(I)** to the underside of desktop A.

ASSEMBLY INSTRUCTIONS

Quadro Square leg 2 person corner workstations T configuration

www.jasonl.com.au

Need help!

Call us on
1300 527 665

jason.l
your office furniture mate



Sizes: 1400Lx1800W , 1600Lx1800W , 1800Lx1800W mm

STEP 9

**If you purchased
with screens divider**

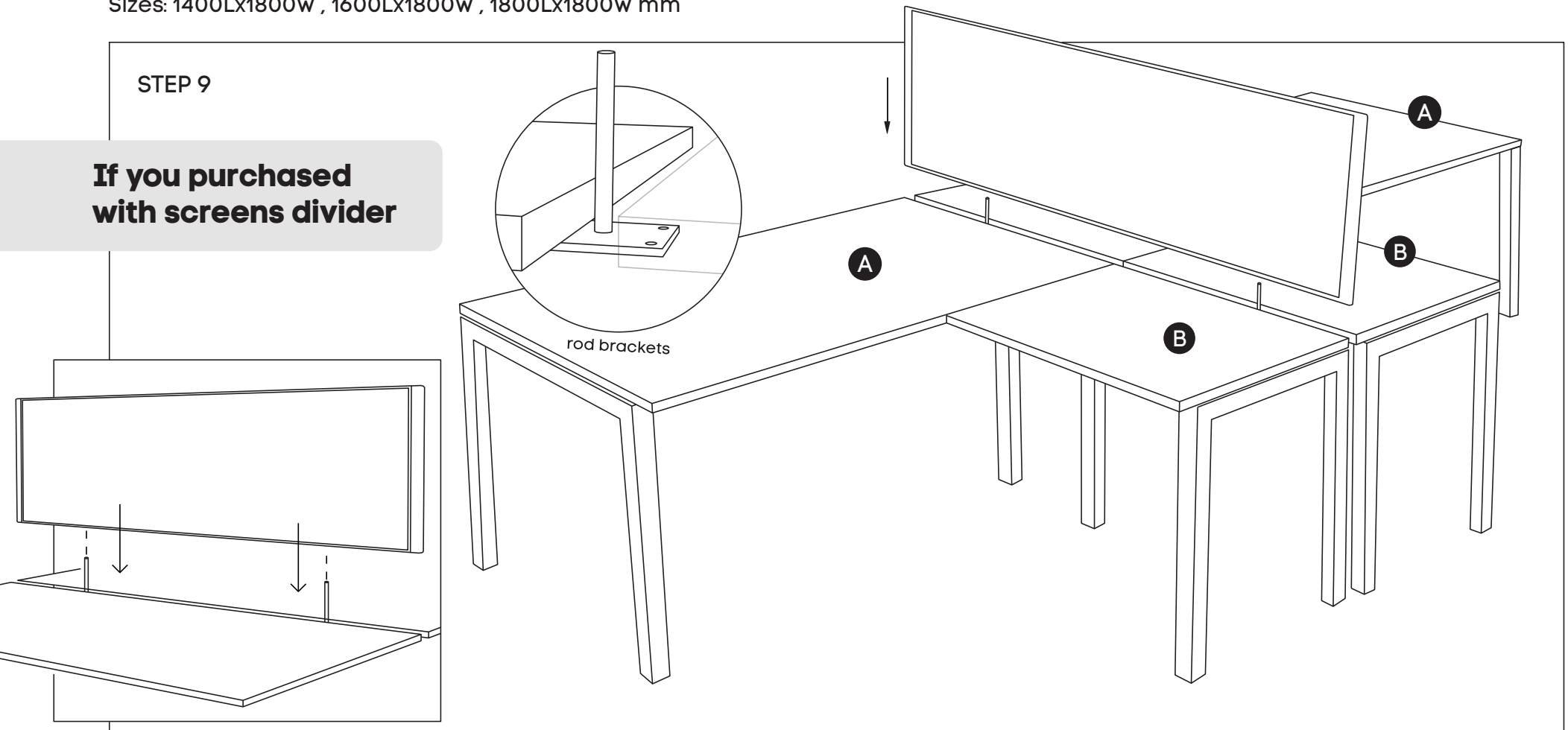

- Please leave 25mm gap between 2 x table top **(A)** so we can drop the return desk mounted screen in between the two tops.
- Please position the screen so that it sits at the same level as the bottom surface of the desktop. Please adjust the screen position to make sure the screen end meet with the the desk end and please hold the screen.
- Second person to insert single desk mounted rod brackets. The brackets rod goes inside the pre-drilled screens holes.
- The screen holes are located around 300mm from the screen end each. First person to hold screen stand still.

ASSEMBLY INSTRUCTIONS

Quadro Square leg 2 person corner workstations T configuration

www.jasonl.com.au

Need help!
Call us on
1300 527 665

jason.l
your office furniture mate



Sizes: 1400Lx1800W , 1600Lx1800W , 1800Lx1800W mm

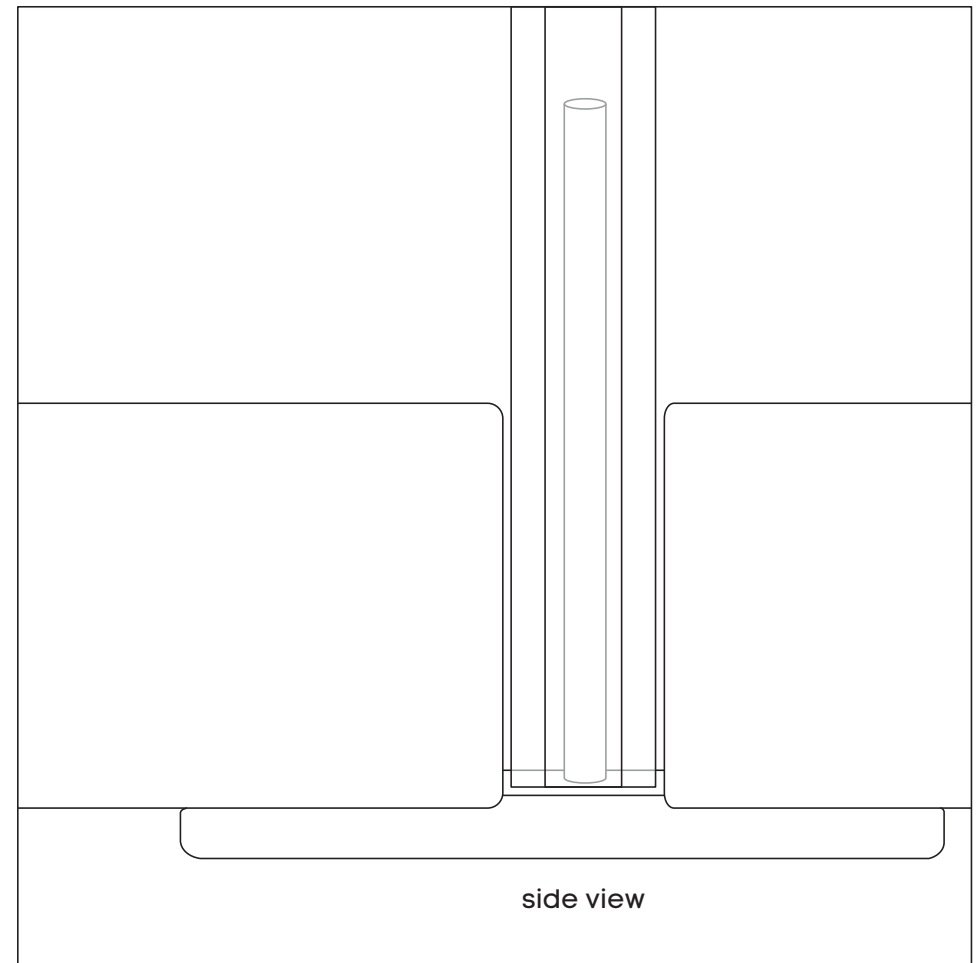
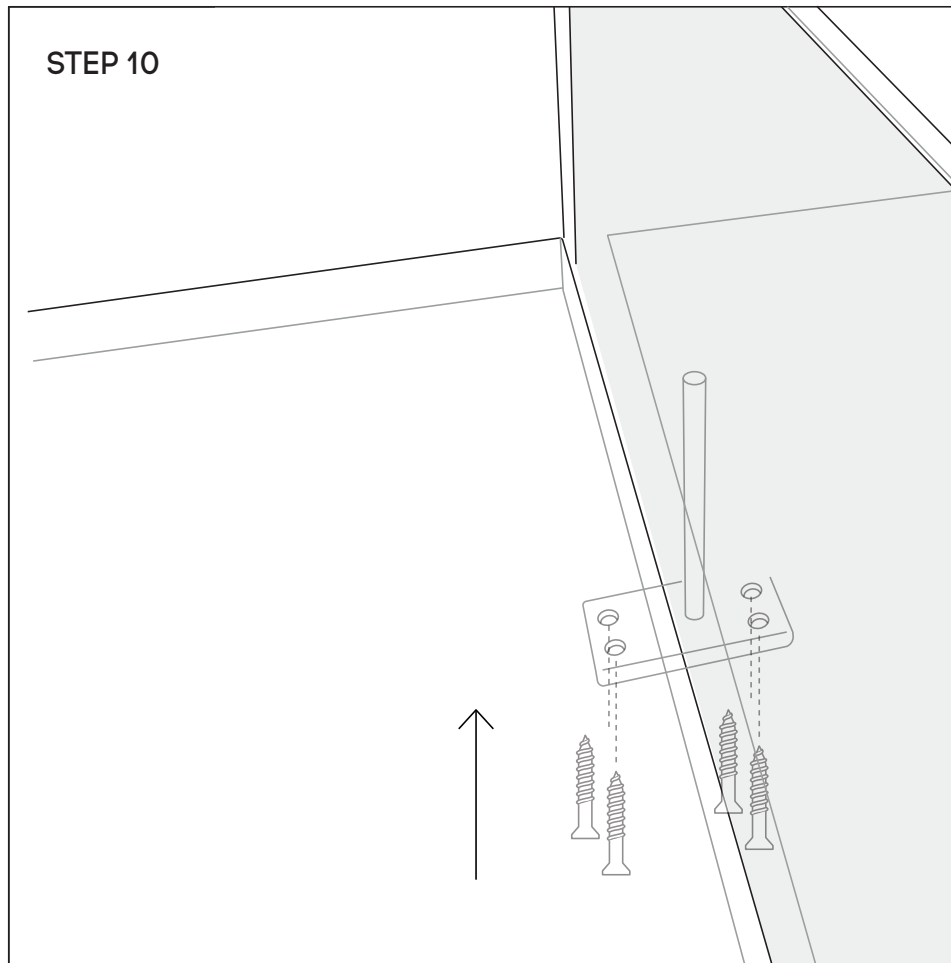

Second person to drill 4 holes into the brackets holes with provided wood screws into the underneath desktop.
Please check the position of the rod brackets and bracket holes again before drilling the screws all the way through. Please tighten all the wood screws.

ASSEMBLY INSTRUCTIONS

Quadro Square leg 2 person corner workstations T configuration

www.jasonl.com.au

Need help!
Call us on
1300 527 665

jason.l
your office furniture mate



Sizes: 1400Lx1800W , 1600Lx1800W , 1800Lx1800W mm

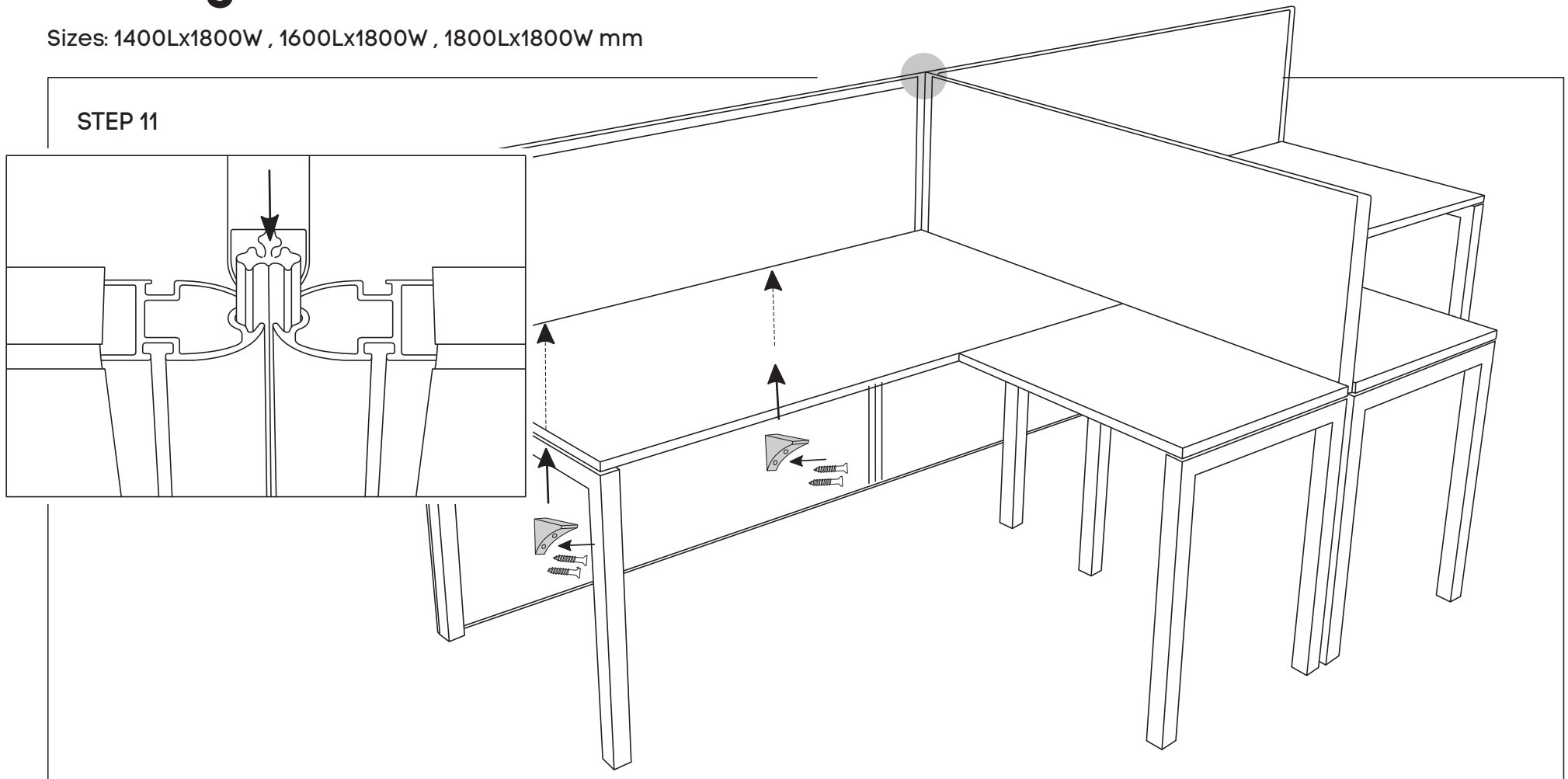

Floor based screen divider assembly instruction:

- Using an Allen key remove top 3 caps from all screens uprights. Bring three partition towards one another and slide the 3 way connector rod - down between the three screen uprights.
- Under the desktops, use I-shaped panel brackets to secure the screens to the table tops **(A)**. Place two brackets in each screen.