

# ASSEMBLY INSTRUCTIONS

## Quadro Loop leg 4 person Corner workstation

Sizes: 1400Lx1800W , 1600Lx1800W , 1800Lx1800W mm

[www.jasonl.com.au](http://www.jasonl.com.au)

**Need help!**  
Call us on  
**1300 527 665**

**jason.l**  
your office furniture mate

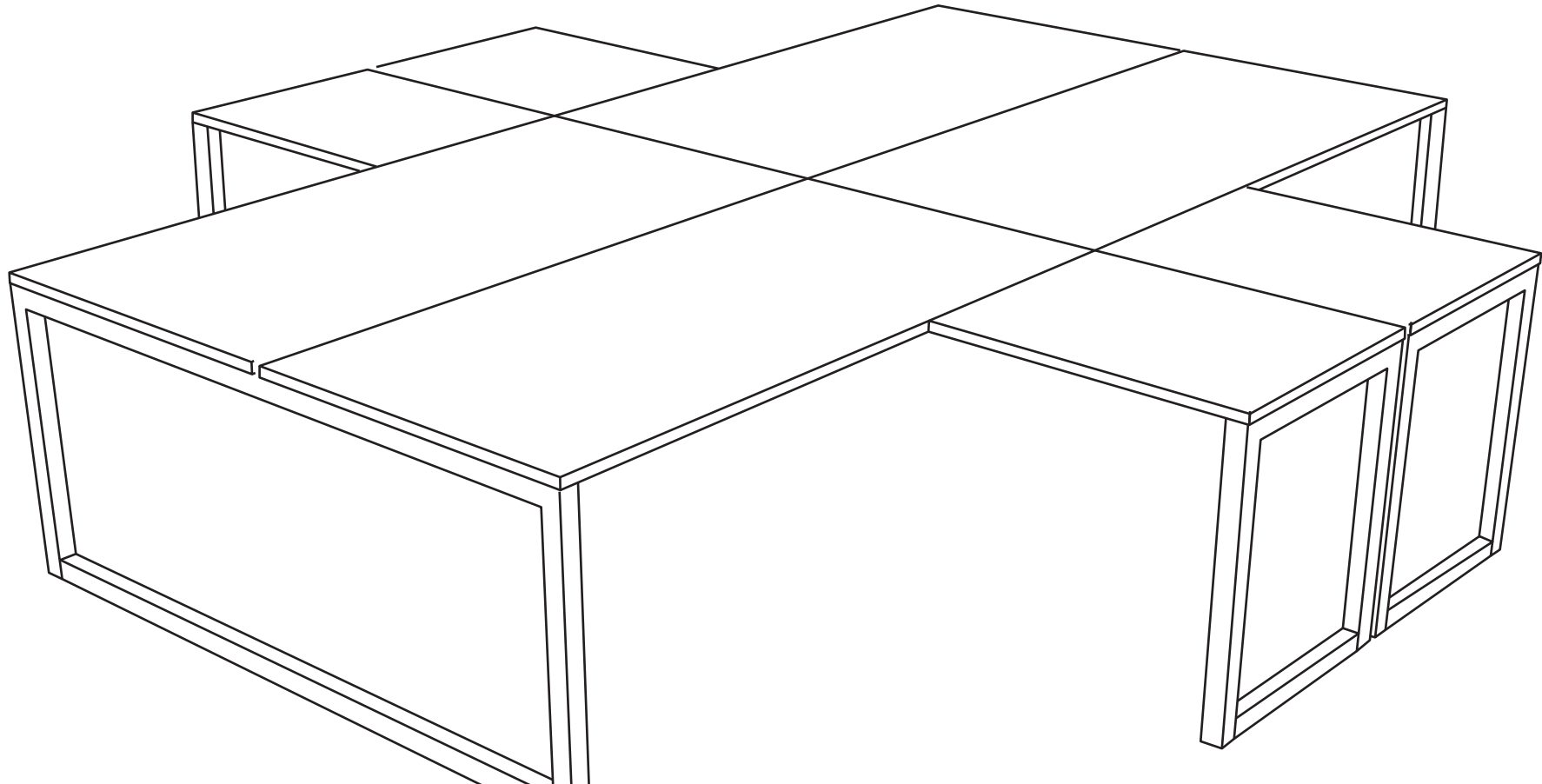

**Tools Required:** Power screwdriver; Allen key set (provided)

 2 persons required for installation

# ASSEMBLY INSTRUCTIONS

## Quadro Loop leg 4 person Corner workstation

Sizes: 1400Lx1800W , 1600Lx1800W , 1800Lx1800W mm

[www.jasonl.com.au](http://www.jasonl.com.au)

**Need help!**  
Call us on  
**1300 527 665**

**jason.l**  
your office furniture mate

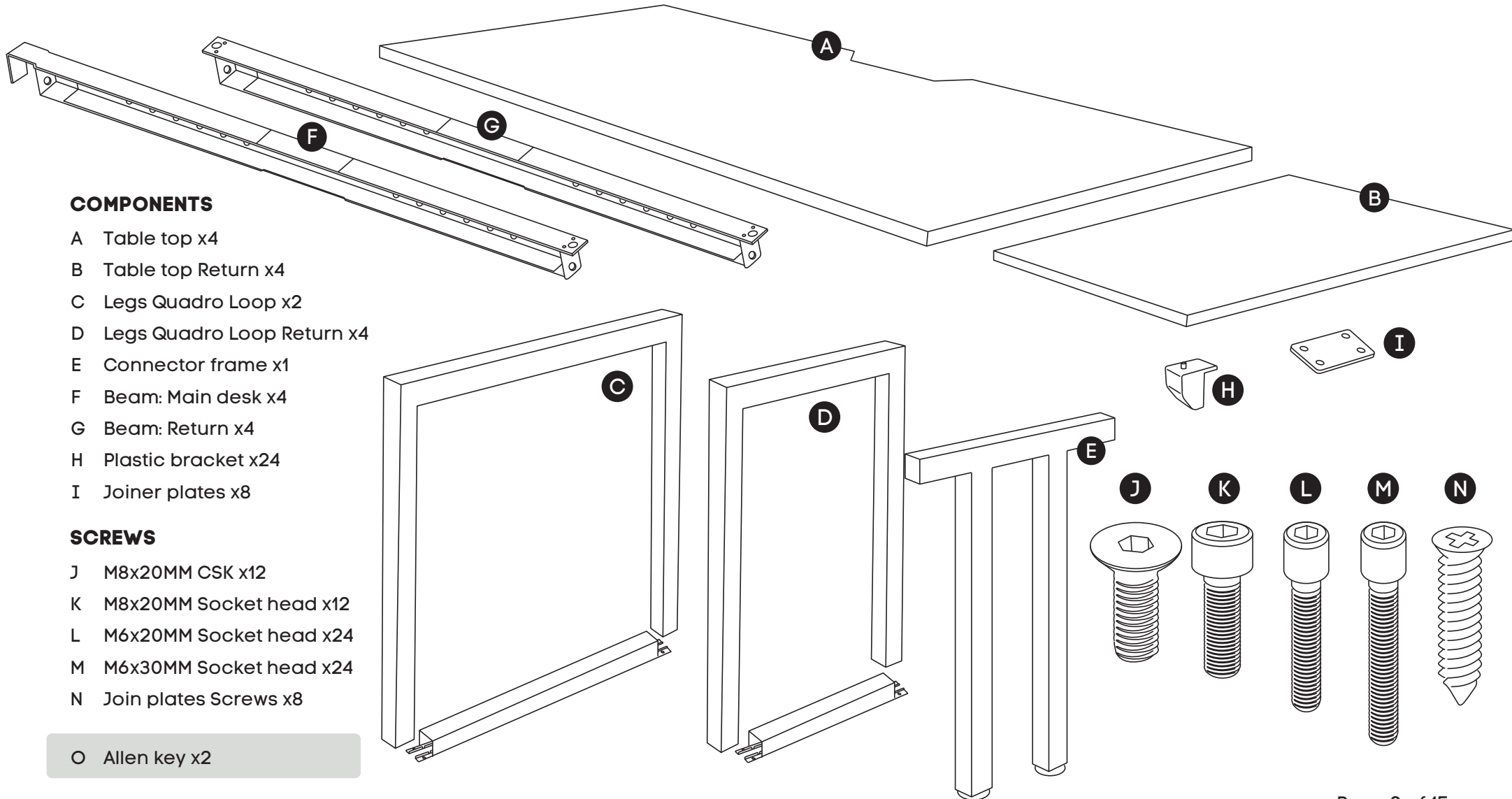

### COMPONENTS

- A Table top x4
- B Table top Return x4
- C Legs Quadro Loop x2
- D Legs Quadro Loop Return x4
- E Connector frame x1
- F Beam: Main desk x4
- G Beam: Return x4
- H Plastic bracket x24
- I Joiner plates x8

### SCREWS

- J M8x20MM CSK x12
- K M8x20MM Socket head x12
- L M6x20MM Socket head x24
- M M6x30MM Socket head x24
- N Join plates Screws x8

O Allen key x2

# ASSEMBLY INSTRUCTIONS

## Quadro Loop leg 4 person Corner workstation

Sizes: 1400Lx1800W , 1600Lx1800W , 1800Lx1800W mm

[www.jasonl.com.au](http://www.jasonl.com.au)

**Need help!**  
Call us on  
**1300 527 665**

**jason.l**  
your office furniture mate



The first step is to assemble the workstation frame, without table tops and without returns frames and tops.

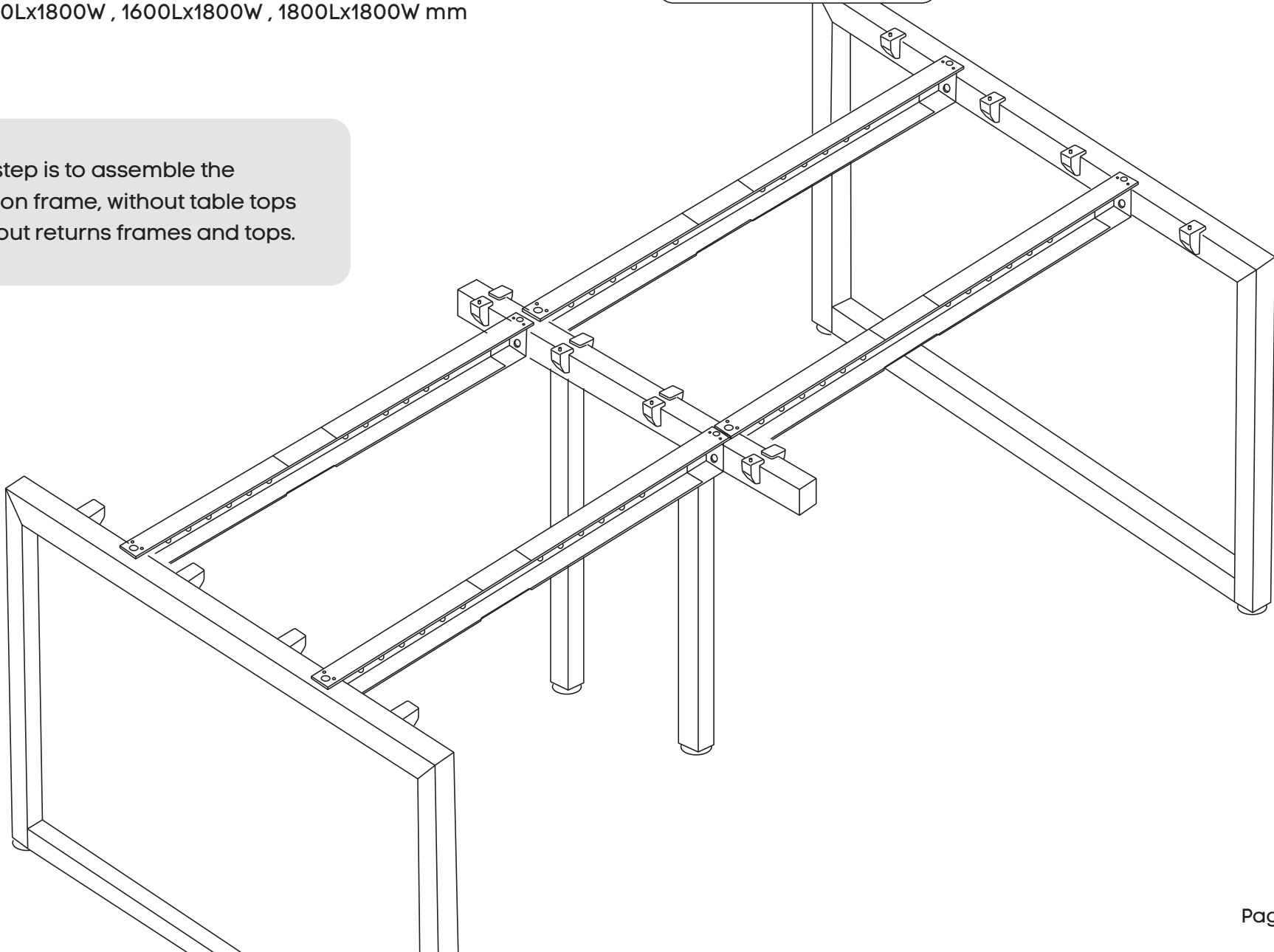

# ASSEMBLY INSTRUCTIONS

## Quadro Loop leg 4 person Corner workstation

Sizes: 1400Lx1800W , 1600Lx1800W , 1800Lx1800W mm

[www.jasonl.com.au](http://www.jasonl.com.au)

**Need help!**

Call us on  
**1300 527 665**

**jason.l**  
your office furniture mate

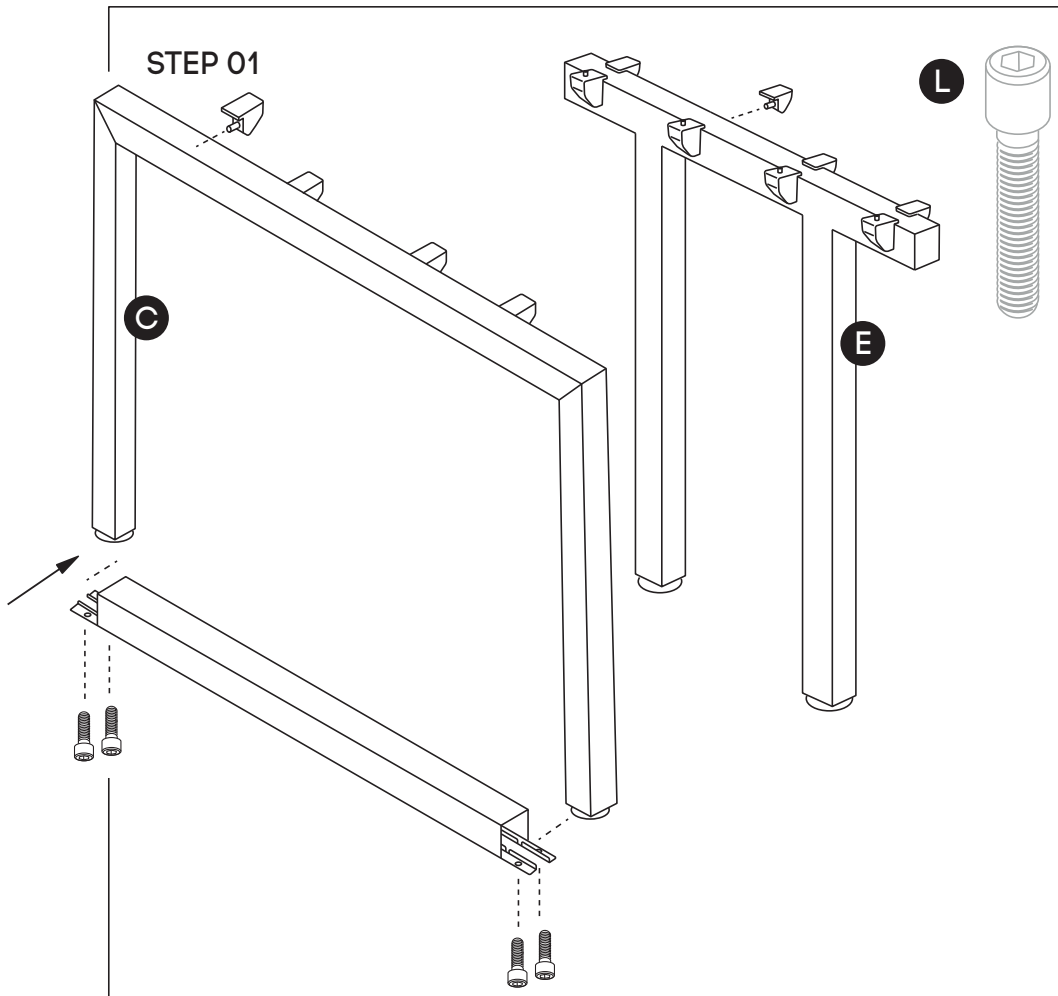

Using Allen Key provided, attach 4 plastic brackets (H) per leg (C) (as per picture above) using M6x20MM (L) Socket head screw. Do the same with Connector frame (E). Connect Loop Legs to Bottom of Quadro Legs (C) by using 4 bolts per leg.

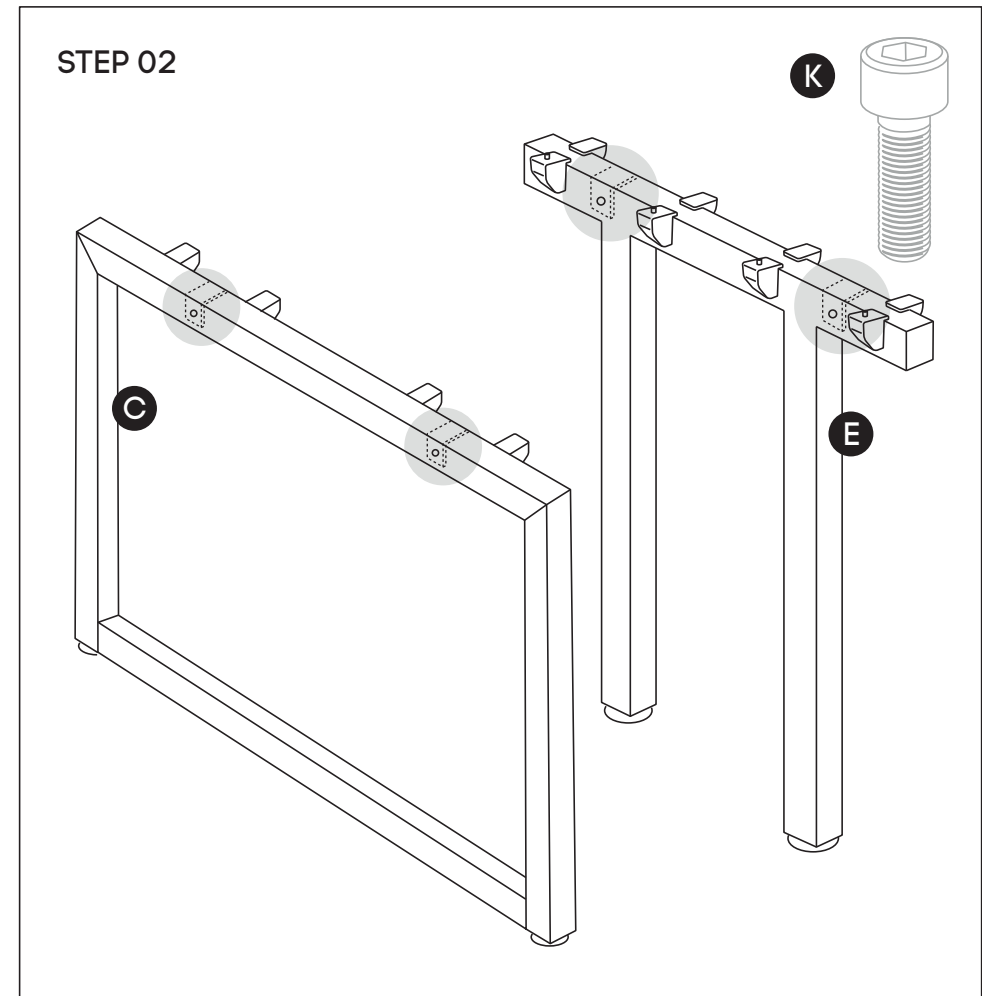

Using Allen Key provided, attach M8x20MM Socket head (K)-screw socket half way into leg for both legs (C) and into Connector frame (E).

# ASSEMBLY INSTRUCTIONS

## Quadro Loop leg 4 person Corner workstation

[www.jasonl.com.au](http://www.jasonl.com.au)

**Need help!**  
Call us on  
**1300 527 665**

**jason.l**  
your office furniture mate



Sizes: 1400Lx1800W , 1600Lx1800W , 1800Lx1800W mm

### STEP 03

Adjust extendable main desk beans (**F**) to desired length using markers and secure beam at that length using screws provided

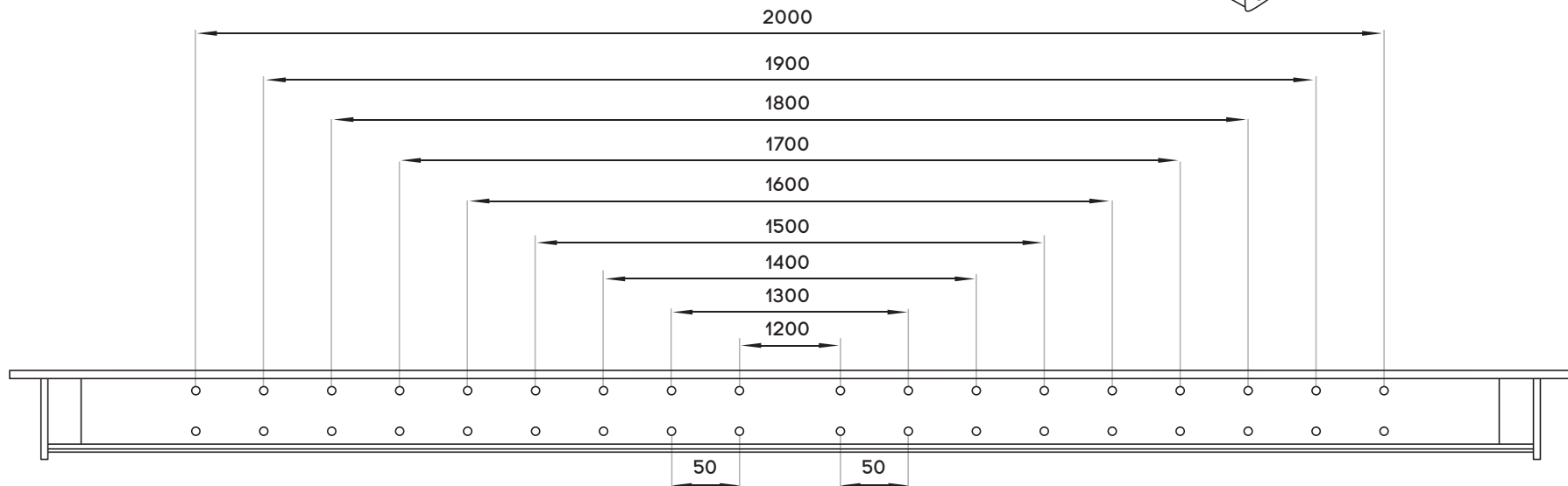
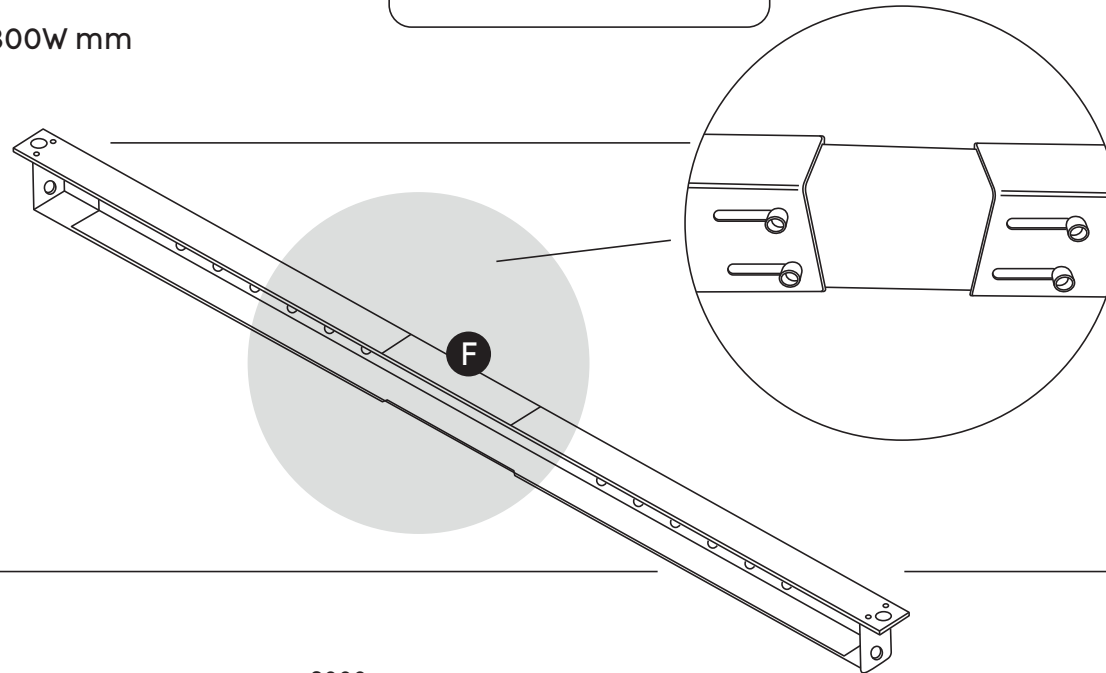

# ASSEMBLY INSTRUCTIONS

## Quadro Loop leg 4 person Corner workstation

Sizes: 1400Lx1800W , 1600Lx1800W , 1800Lx1800W mm

[www.jasonl.com.au](http://www.jasonl.com.au)

**Need help!**  
Call us on  
**1300 527 665**

**jason.l**  
your office furniture mate

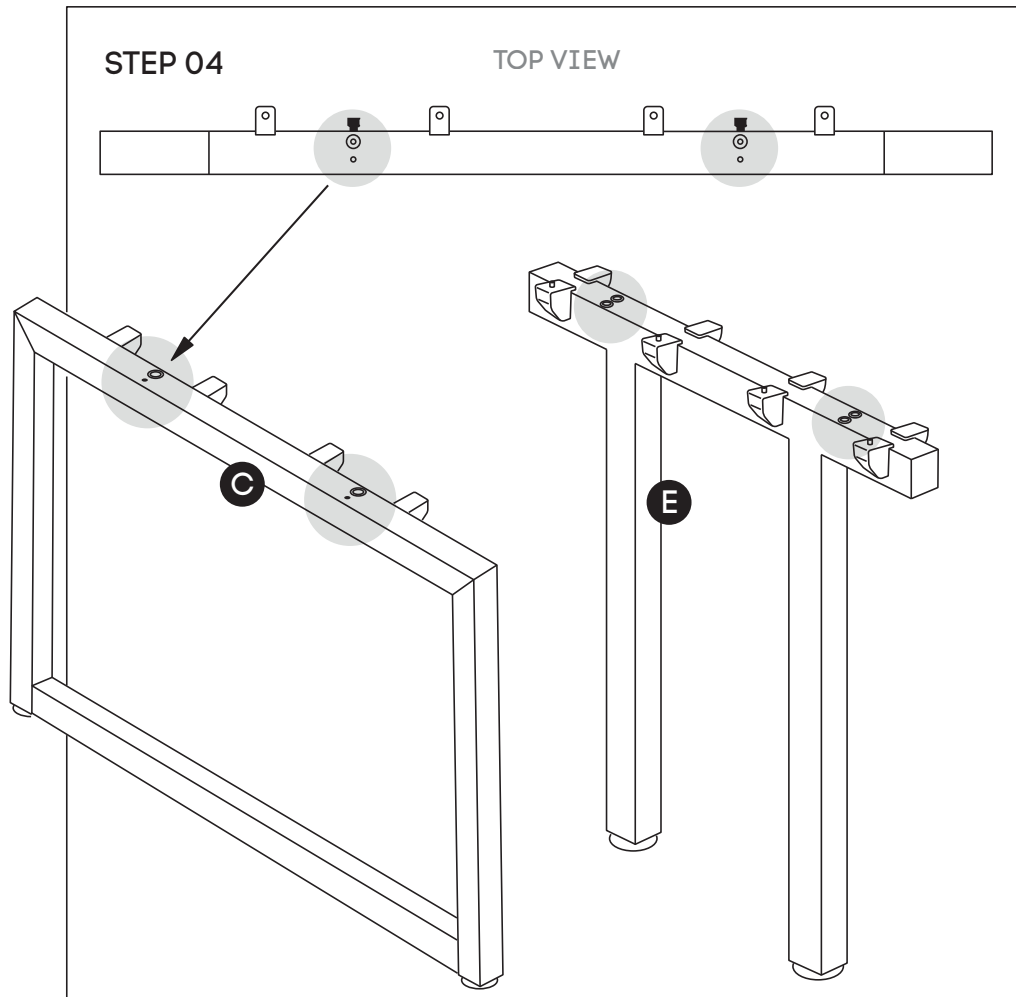

Attach main desk beams **(F)** to legs **(C)** and Connector frame **(E)** using nut insert in legs. See point attached

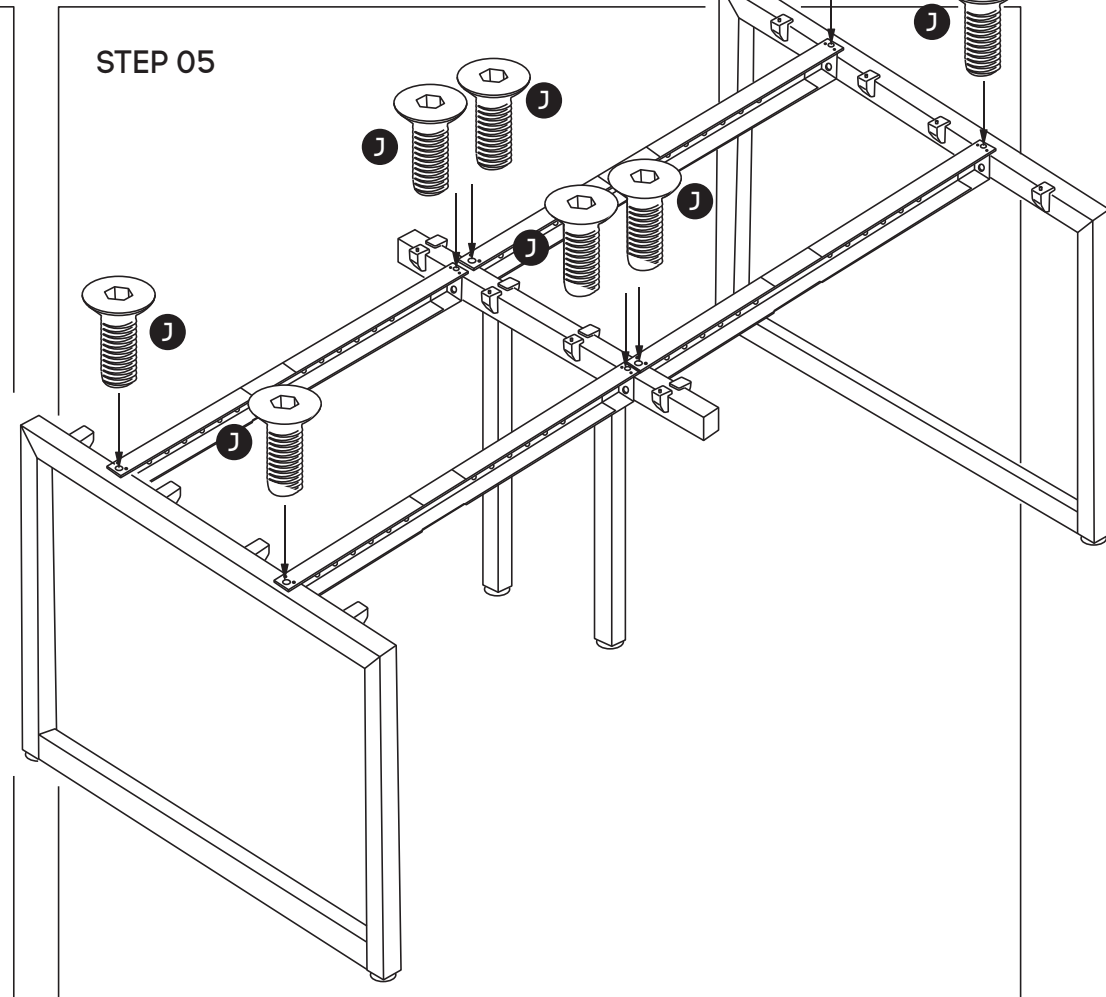

Frame looks like this. Using Allen Key, attach main desks beams **(F)** with Socket **(J)**

# ASSEMBLY INSTRUCTIONS

## Quadro Loop leg 4 person Corner workstation

Sizes: 1400Lx1800W , 1600Lx1800W , 1800Lx1800W mm

[www.jasonl.com.au](http://www.jasonl.com.au)

**Need help!**  
Call us on  
**1300 527 665**

**jason.l**  
your office furniture mate



The next step is to assemble and attach the return structures to the main frame.

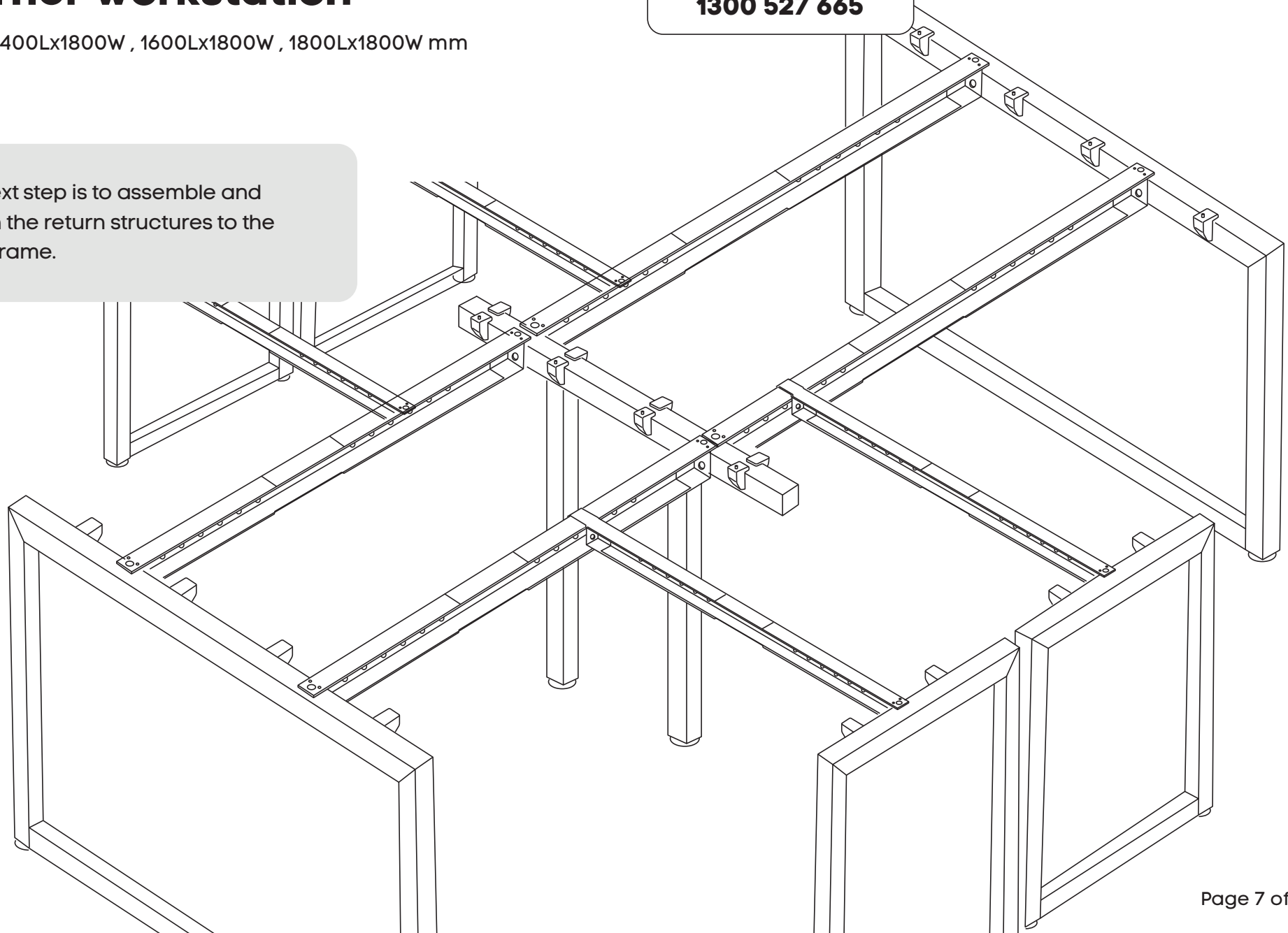

# ASSEMBLY INSTRUCTIONS

## Quadro Loop leg 4 person Corner workstation

[www.jasonl.com.au](http://www.jasonl.com.au)

**Need help!**  
Call us on  
**1300 527 665**

**jason.l**  
your office furniture mate



Sizes: 1400Lx1800W , 1600Lx1800W , 1800Lx1800W mm

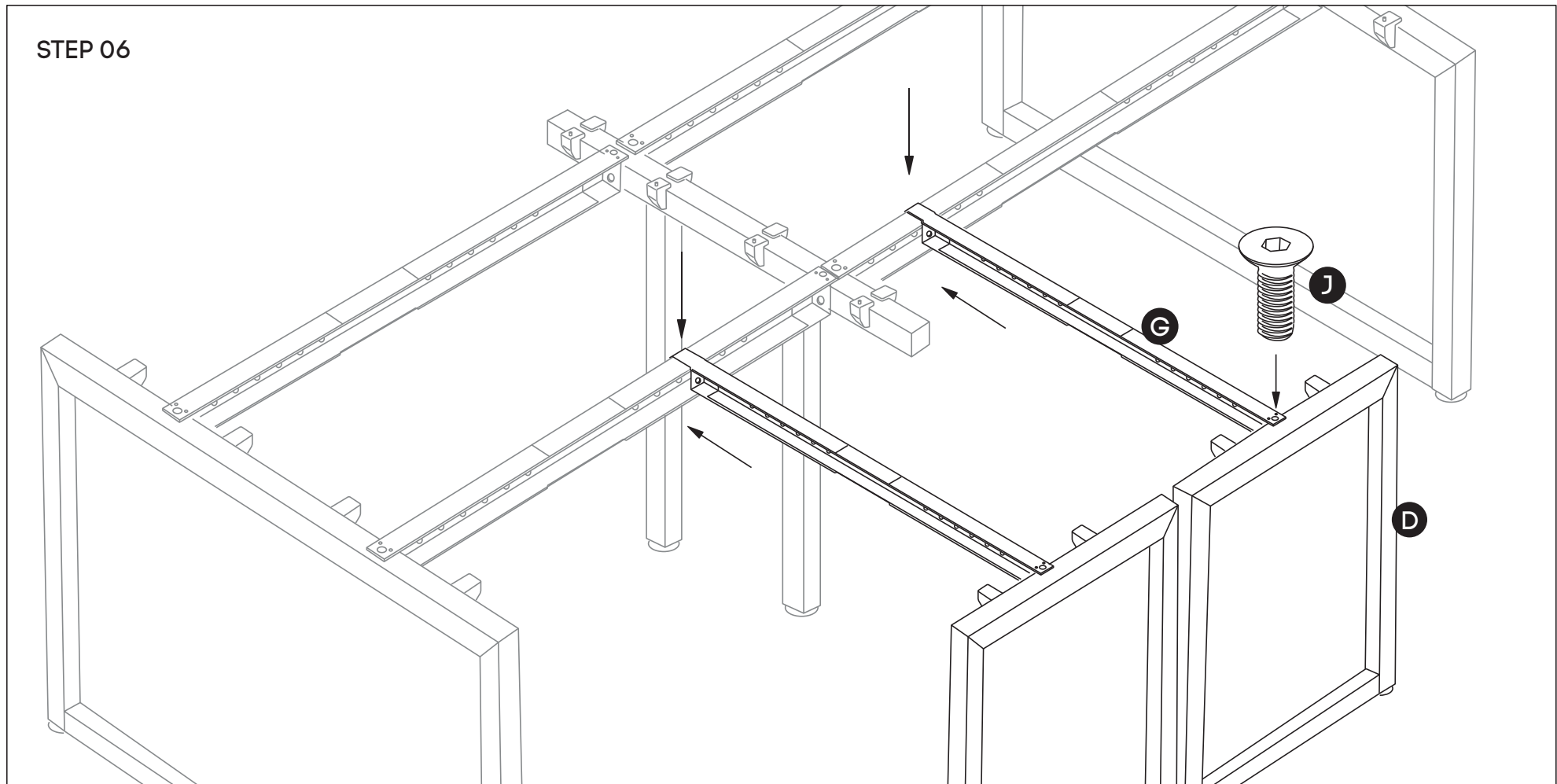

Attach the return beams (**G**) to return legs (**D**) using nut insert in legs. See point attached.  
Then, connect the hook of the return beam to the beam of the main structure.  
Repeat thsi step until the entire frame is complete.



# ASSEMBLY INSTRUCTIONS

## Quadro Loop leg 4 person Corner workstation

Sizes: 1400Lx1800W , 1600Lx1800W , 1800Lx1800W mm

[www.jasonl.com.au](http://www.jasonl.com.au)

**Need help!**  
Call us on  
**1300 527 665**

**jason.l**  
your office furniture mate



The next step is about to add both the main and return table tops over the entire frame.

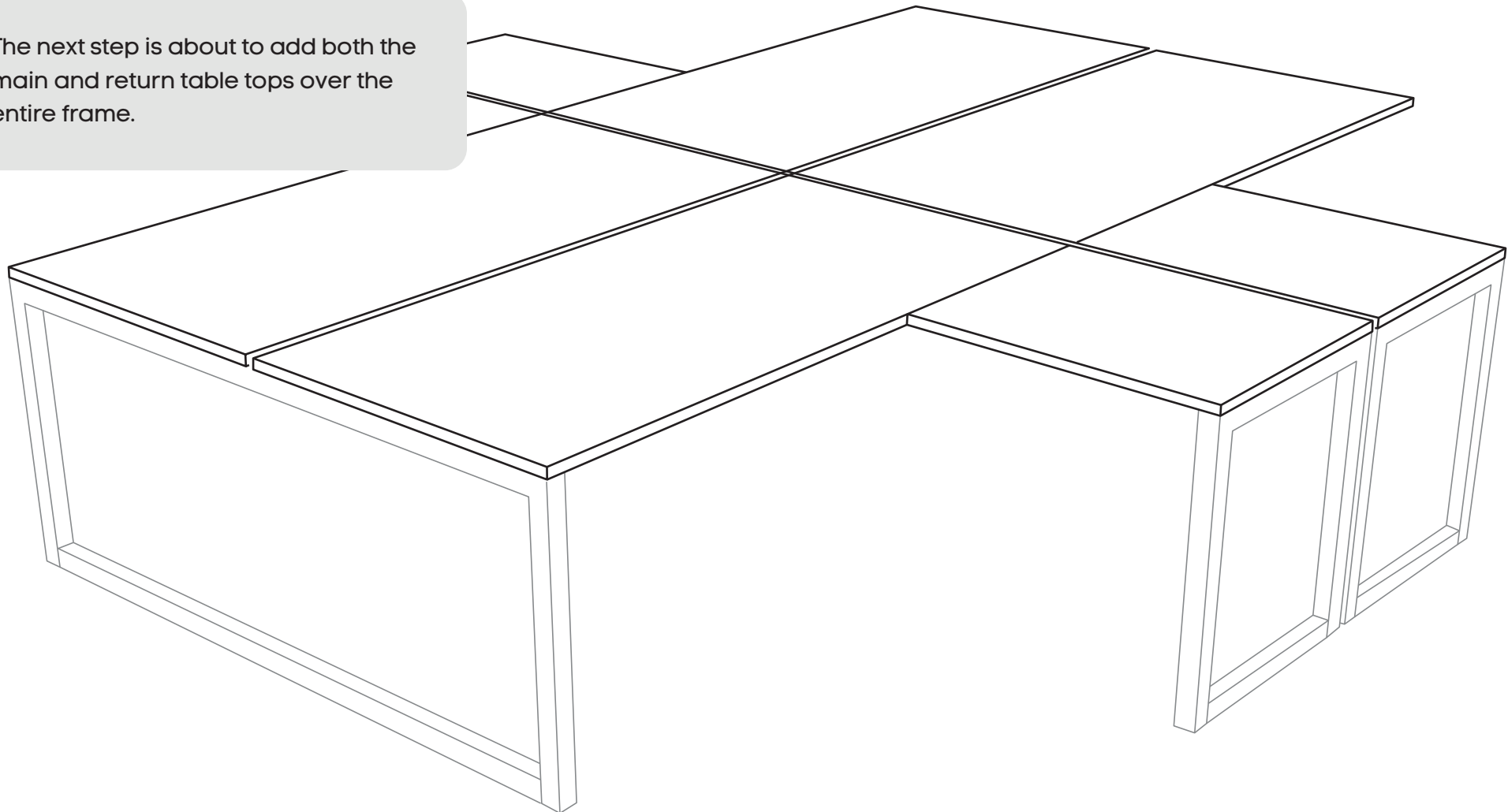

# ASSEMBLY INSTRUCTIONS

## Quadro Loop leg 4 person Corner workstation

Sizes: 1400Lx1800W , 1600Lx1800W , 1800Lx1800W mm

[www.jasonl.com.au](http://www.jasonl.com.au)

**Need help!**  
Call us on  
**1300 527 665**

**jason.l**  
your office furniture mate



STEP 07

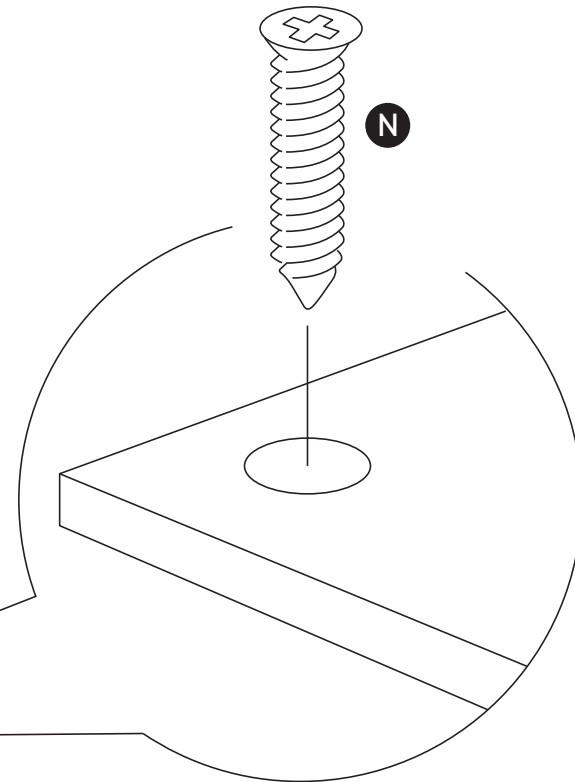
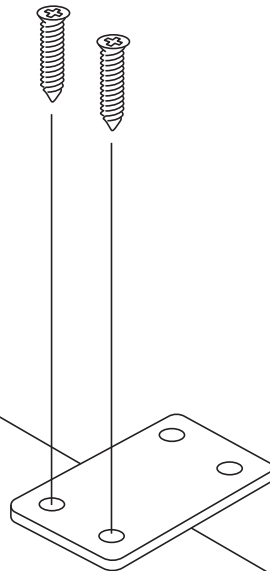
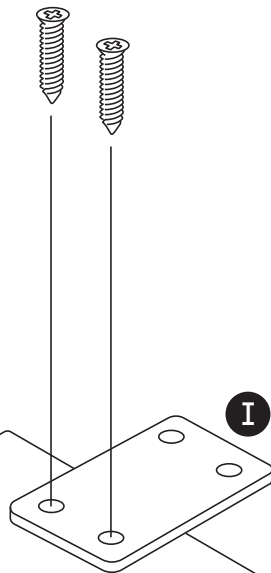

Attach Connector Plates **(I)** to Return Top **(B)** by tightening Screws **(N)**

# ASSEMBLY INSTRUCTIONS

## Quadro Loop leg 4 person Corner workstation

Sizes: 1400Lx1800W , 1600Lx1800W , 1800Lx1800W mm

[www.jasonl.com.au](http://www.jasonl.com.au)

**Need help!**  
Call us on  
**1300 527 665**

**jason.l**  
your office furniture mate

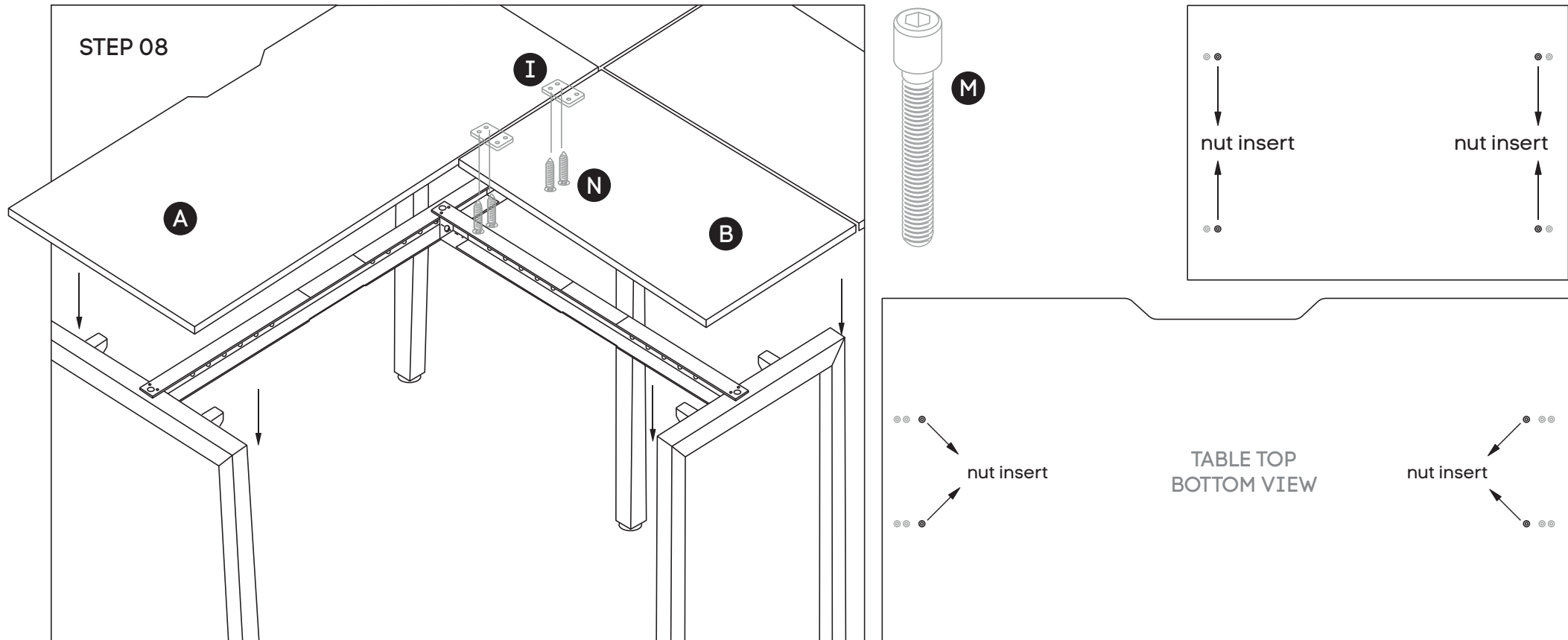

- Place table tops **(A)** on top of frame - with cutout at the back of the desk. Please leave 25mm gap between 2 x table top **(A)** so we can drop the return desk mounted screen in between the two tops.
- Using nut inserts in the desk, use M6x30mm socket **(M)** and attach desktop to the frame.
- Using nut inserts in the desktop, use M6x30mm socket **(M)** and attach return desktops **(B)** to the frame.
- Once desktop are attached and secure to the frame, use woods screws **(N)** and secure joiner plates **(I)** to the underside of desktop A.

# ASSEMBLY INSTRUCTIONS

## Quadro Loop leg 4 person Corner workstation

Sizes: 1400Lx1800W , 1600Lx1800W , 1800Lx1800W mm

[www.jasonl.com.au](http://www.jasonl.com.au)

**Need help!**  
Call us on  
**1300 527 665**

**jason.l**  
your office furniture mate



**If you have purchased with  
desk mounted screens**

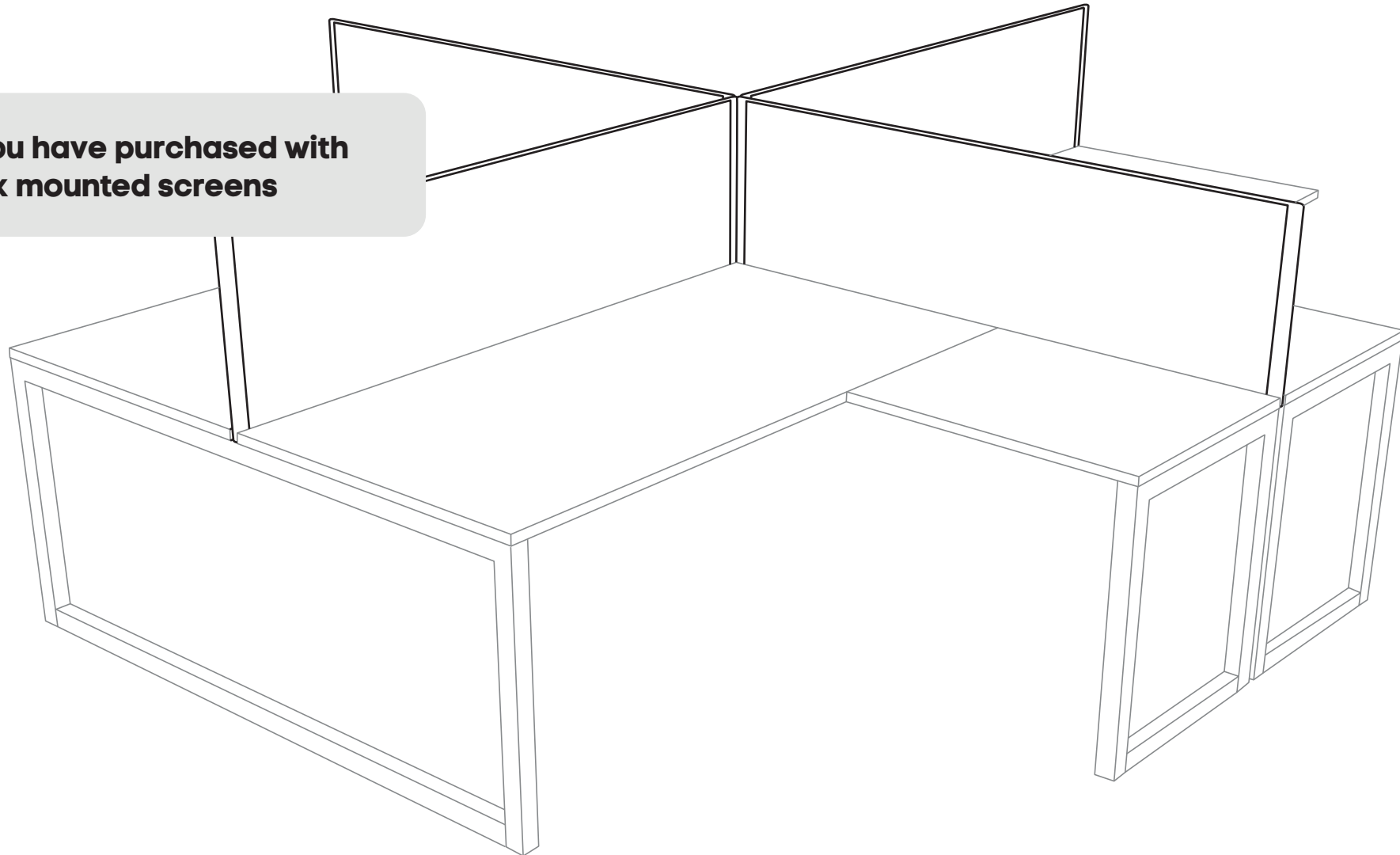

# ASSEMBLY INSTRUCTIONS

## Quadro Loop leg 4 person Corner workstation

Sizes: 1400Lx1800W , 1600Lx1800W , 1800Lx1800W mm

[www.jasonl.com.au](http://www.jasonl.com.au)

**Need help!**  
Call us on  
**1300 527 665**

**jason.l**  
your office furniture mate

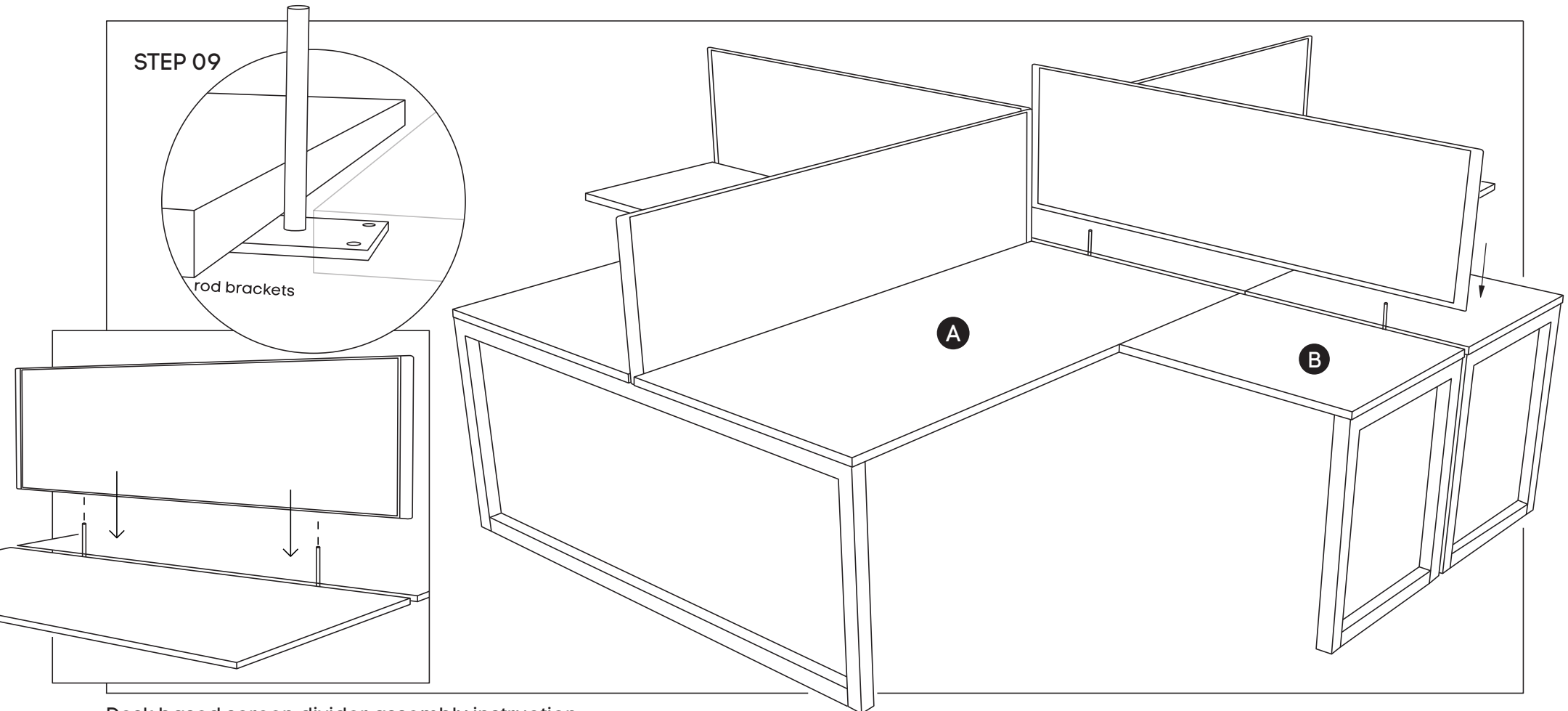

Desk based screen divider assembly instruction:

- Please position the screen so that it sits at the same level as the bottom surface of the desktop. Please adjust the screen position to make sure the screen end meet with the the desk end and please hold the screen.
- Second person to insert single desk mounted rod brackets. The brackets rod goes inside the pre-drilled screens holes.
- The screen holes are located around 300mm from the screen end each. First person to hold screen stand still.

# ASSEMBLY INSTRUCTIONS

## Quadro Loop leg 4 person Corner workstation

Sizes: 1400Lx1800W , 1600Lx1800W , 1800Lx1800W mm

[www.jasonl.com.au](http://www.jasonl.com.au)

**Need help!**  
Call us on  
**1300 527 665**

**jason.l**  
your office furniture mate

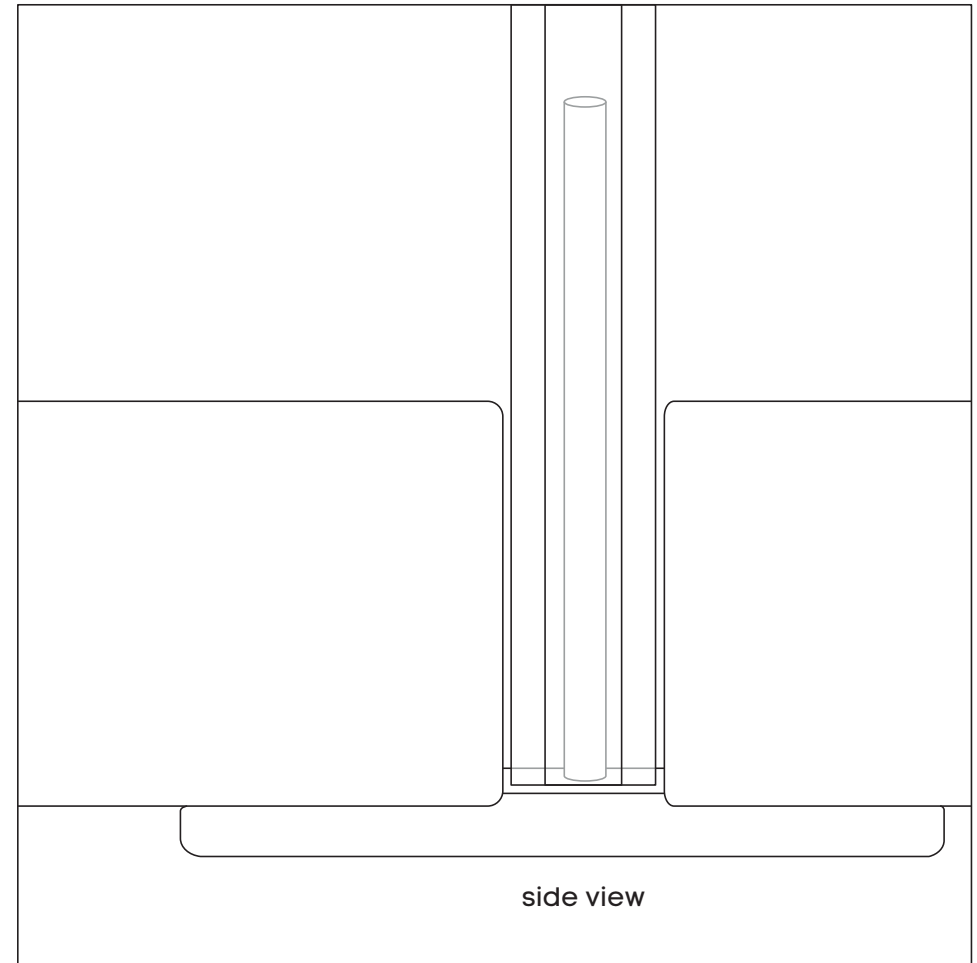
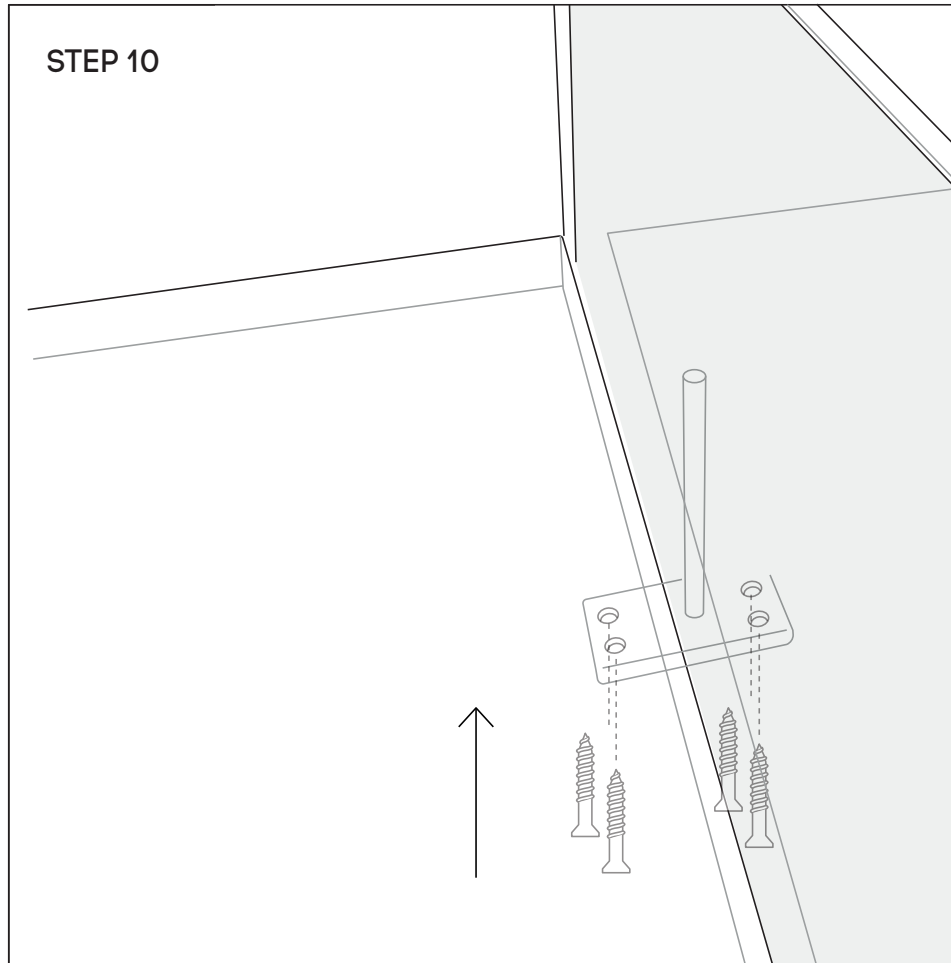

Second person to drill 4 holes into the brackets holes with provided wood screws into the underneath desktop.  
Please check the position of the rod brackets and bracket holes again before drilling the screws all the way through. Please tighten all the wood screws.

# ASSEMBLY INSTRUCTIONS

## Quadro Loop leg 4 person Corner workstation

Sizes: 1400Lx1800W , 1600Lx1800W , 1800Lx1800W mm

[www.jasonl.com.au](http://www.jasonl.com.au)

**Need help!**  
Call us on  
**1300 527 665**

**jason.l**  
your office furniture mate

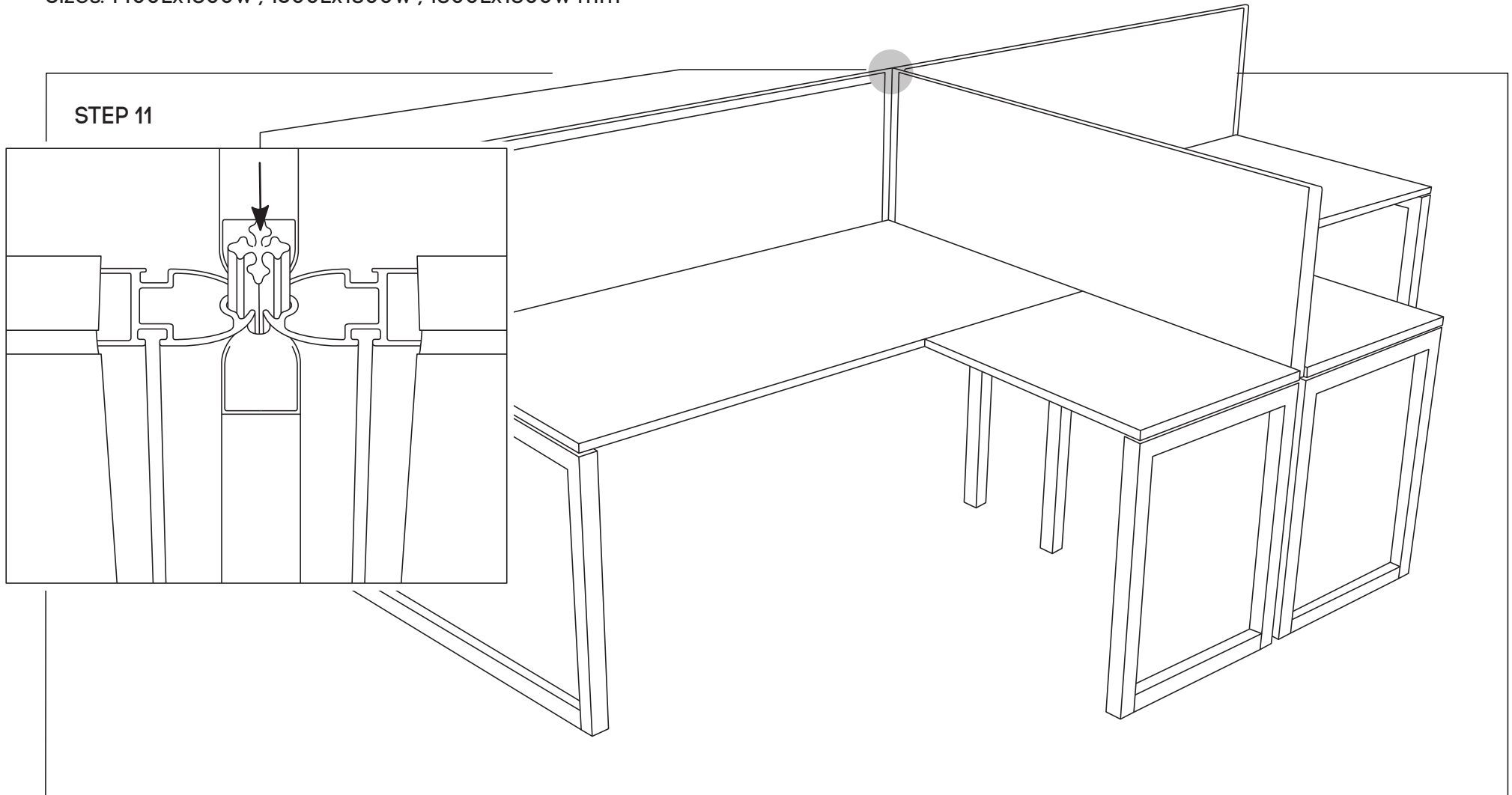

- Using an Allen key remove top 4 caps from all screens uprights. Bring four partition towards one another and slide the 4 way connector rod - down between the four screen uprights.