

**ASSEMBLY INSTRUCTIONS**  
**Quadro Loop desk**

Size: 1000L x 600W mm

[www.jasonl.com.au](http://www.jasonl.com.au)

**Need help!**

Call us on  
**1300 527 665**

**jason.l**  
your office furniture mate

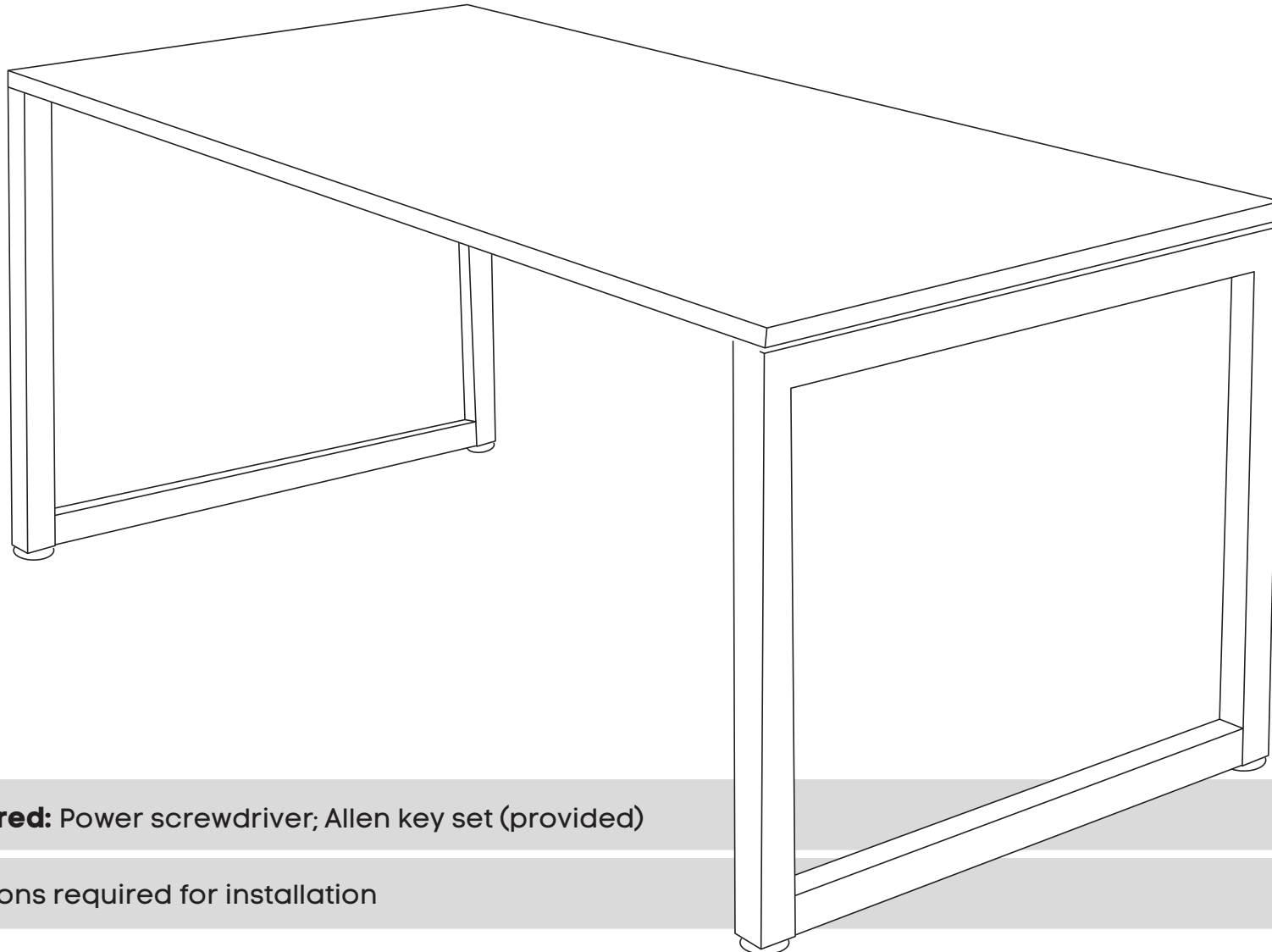

**Tools Required:** Power screwdriver; Allen key set (provided)

 2 persons required for installation

# ASSEMBLY INSTRUCTIONS

## Quadro Loop desk

Size: 1000L x 600W mm

[www.jasonl.com.au](http://www.jasonl.com.au)

**Need help!**

Call us on  
**1300 527 665**

**jason.l**  
your office furniture mate

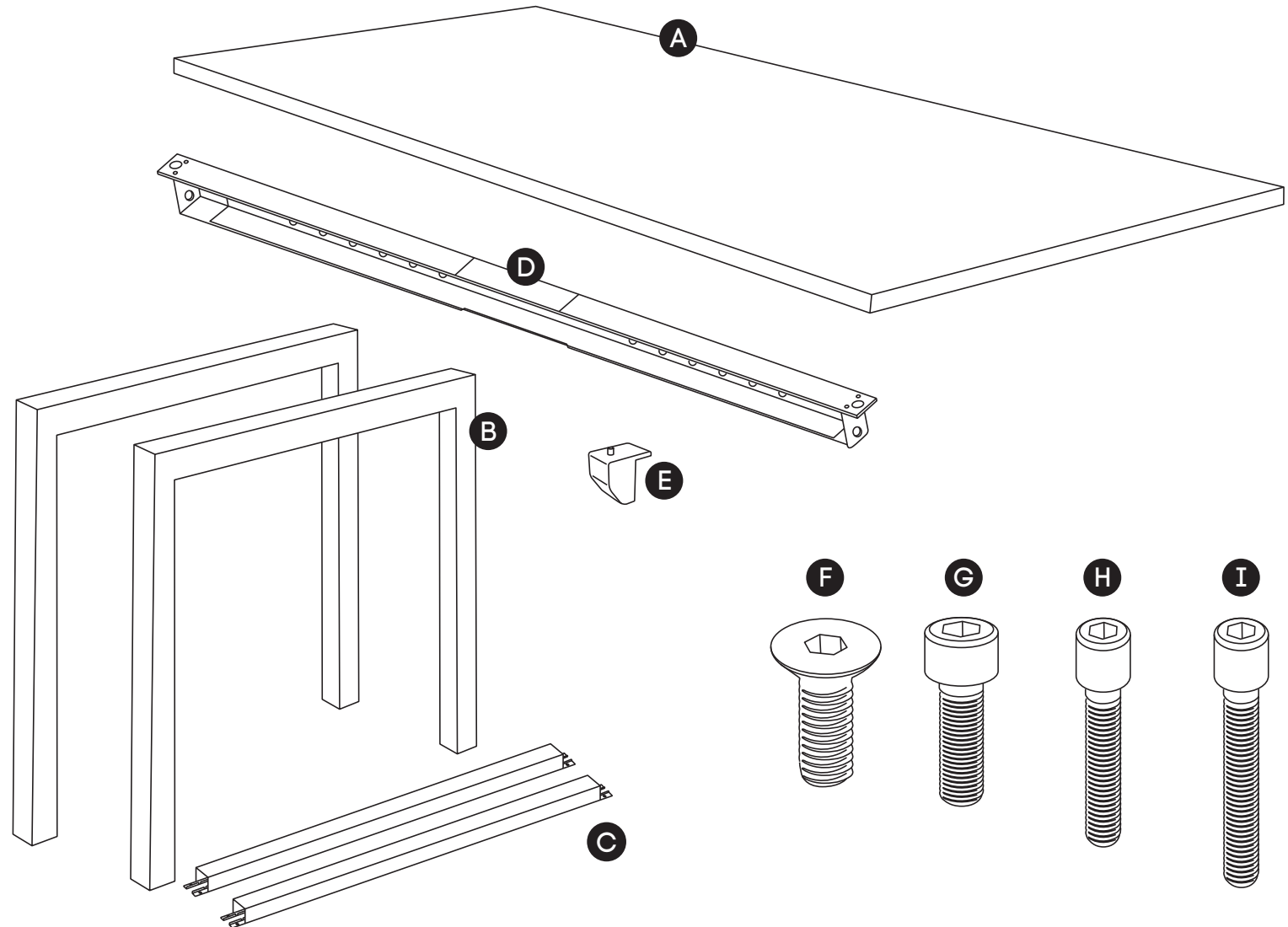

### COMPONENTS

- A Table top x1
- B Legs Quadro x2
- C Legs Quadro Loop x2
- D Beam x1 \*
- E Plastic bracket x4

### SCREWS

- F M8x20MM CSK x1
- G M8x20MM Socket head x1
- H M6x20MM Socket head x2
- I M6x30MM Socket head x2

- J Allen key x2

\* Colour of the beam is always black, regardless desk frame colour.

# ASSEMBLY INSTRUCTIONS

## Quadro Loop desk

Size: 1000L x 600W mm

[www.jasonl.com.au](http://www.jasonl.com.au)

**Need help!**

Call us on  
**1300 527 665**

**jason.l**  
your office furniture mate

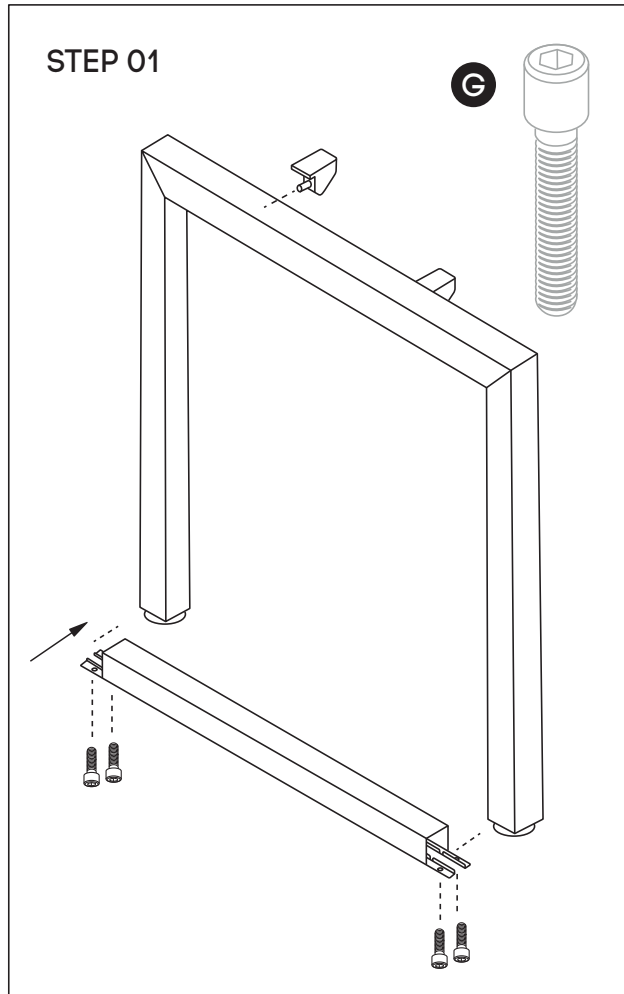

Using Allen Key provided, attach 2 plastic brackets per leg **(E)** (as per picture above) using M6x20MM **(H)** Socket head screw. Connect Loop Legs **(C)** to Bottom of Quadro Legs **(B)** by using 4 bolts per leg.

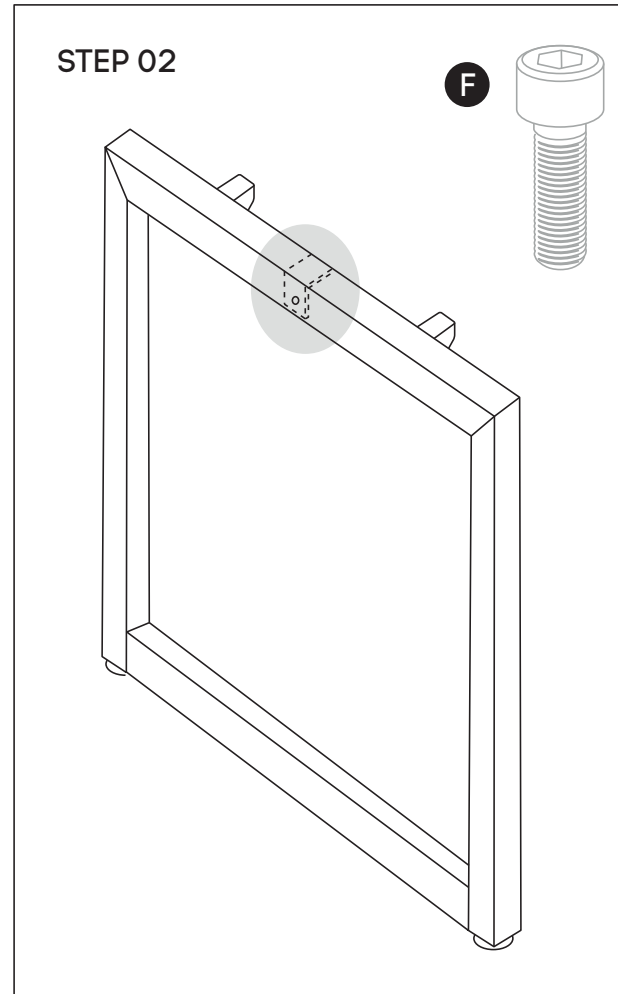

Using Allen Key provided, attach M8x20MM Socket head **(F)** - screw socket half way into leg for both legs **(B)**

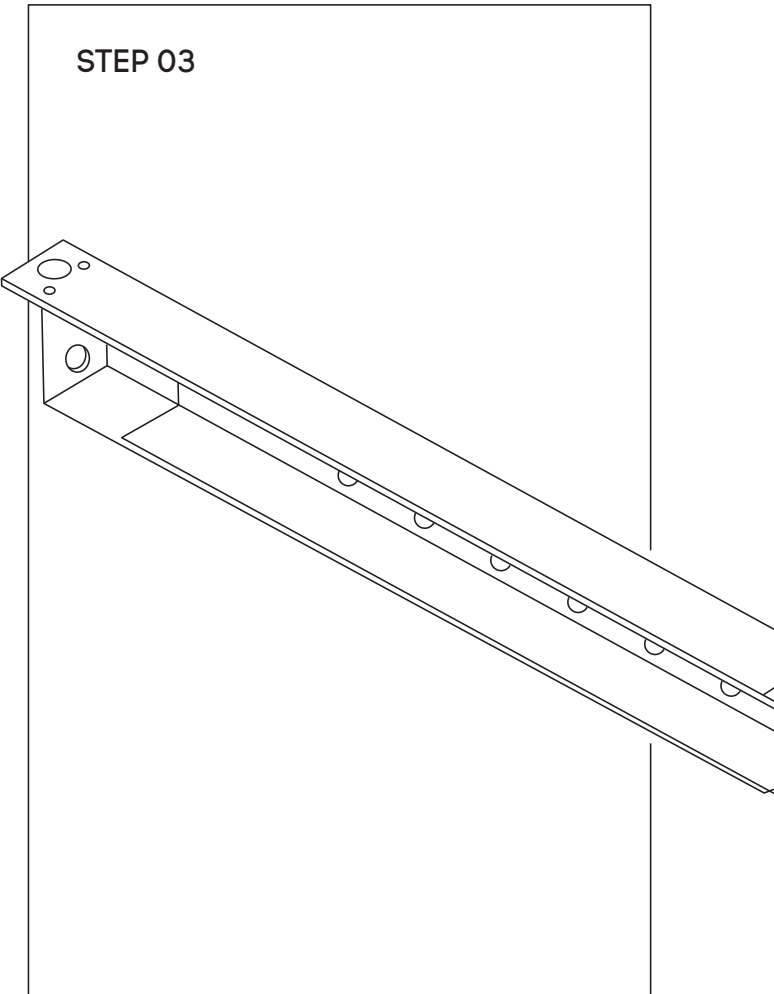

Use fixed beam **(D)** 1000mm and secure beam using screws provided to suit 1000mm desk

# ASSEMBLY INSTRUCTIONS

## Quadro Loop desk

Size: 1000L x 600W mm

[www.jasonl.com.au](http://www.jasonl.com.au)

**Need help!**

Call us on  
**1300 527 665**

**jason.l**  
your office furniture mate

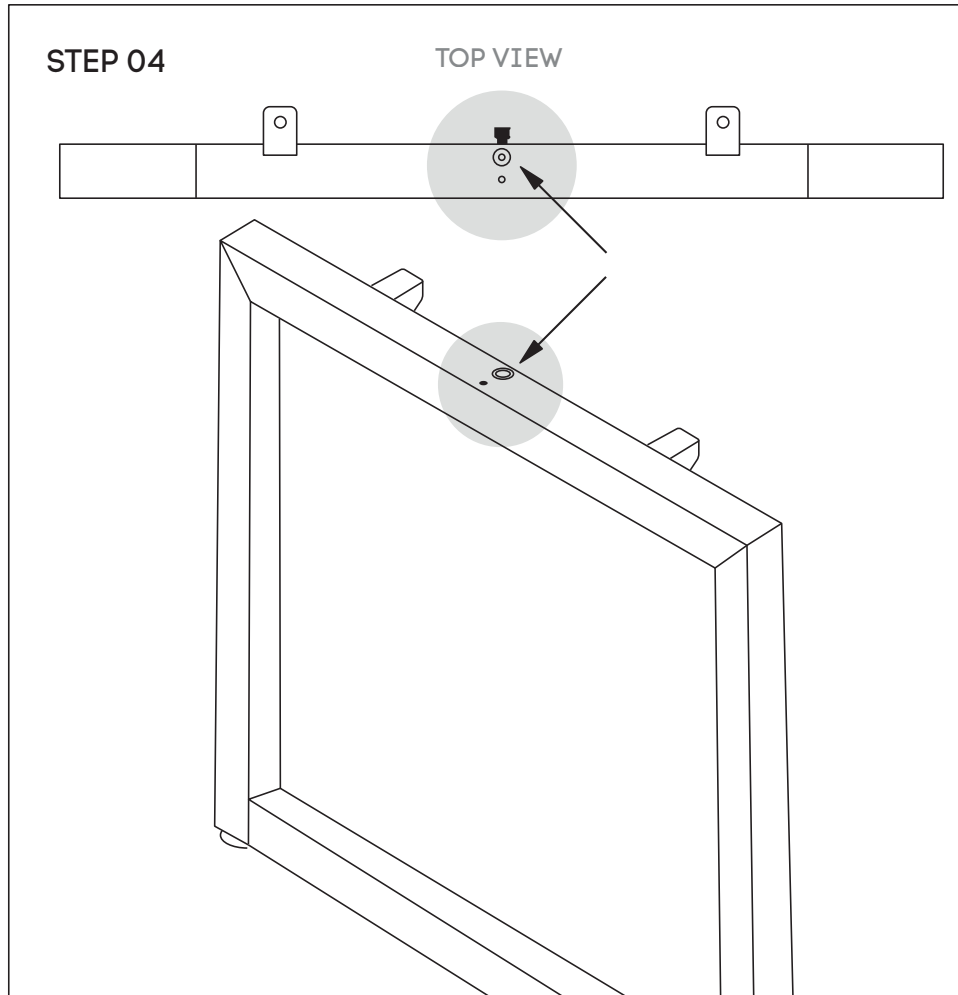
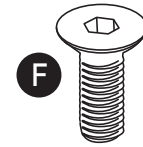

Attach beam **(D)** to legs **(B)** using nut insert in legs  
See point attached

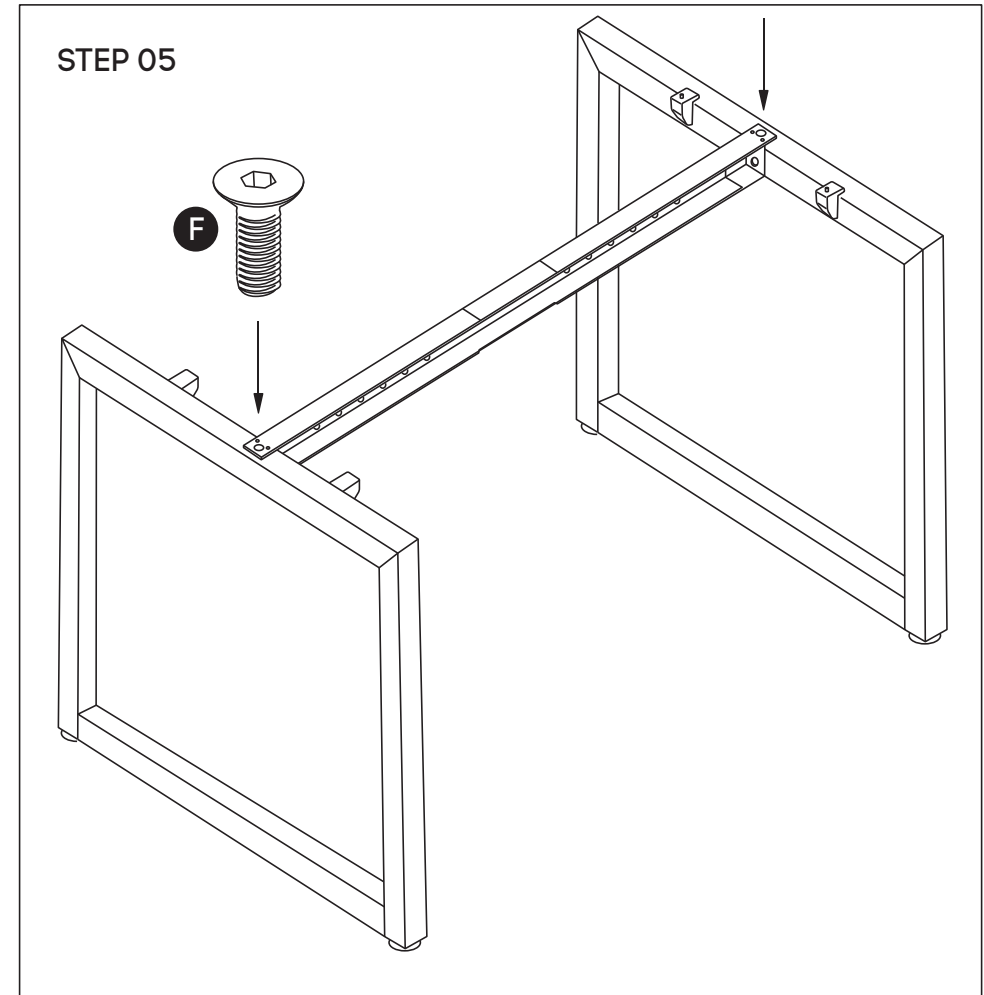

Frame looks like this. Using Allen Key, attach beam **(D)** with Socket **(F)**

# ASSEMBLY INSTRUCTIONS

## Quadro Loop desk

Size: 1000L x 600W mm

[www.jasonl.com.au](http://www.jasonl.com.au)

**Need help!**

Call us on  
**1300 527 665**

**jason.l**  
your office furniture mate

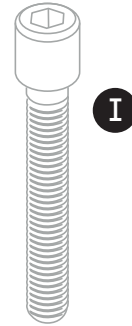
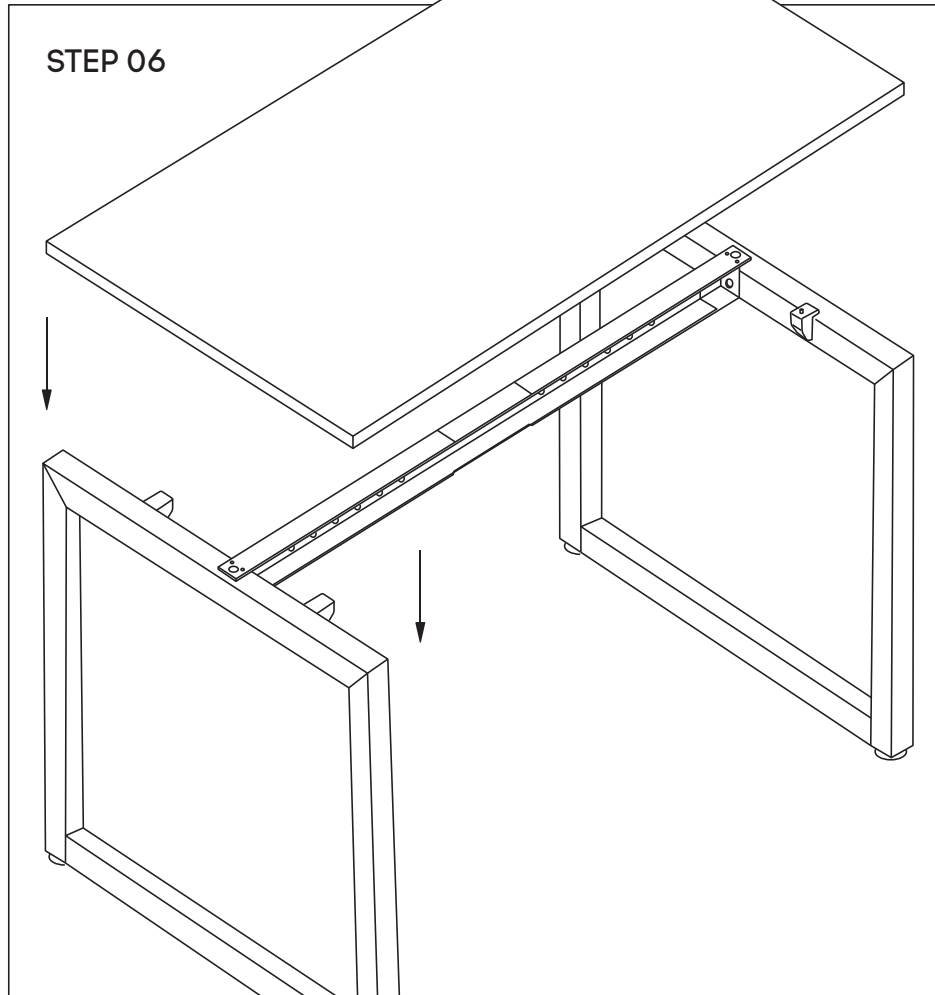
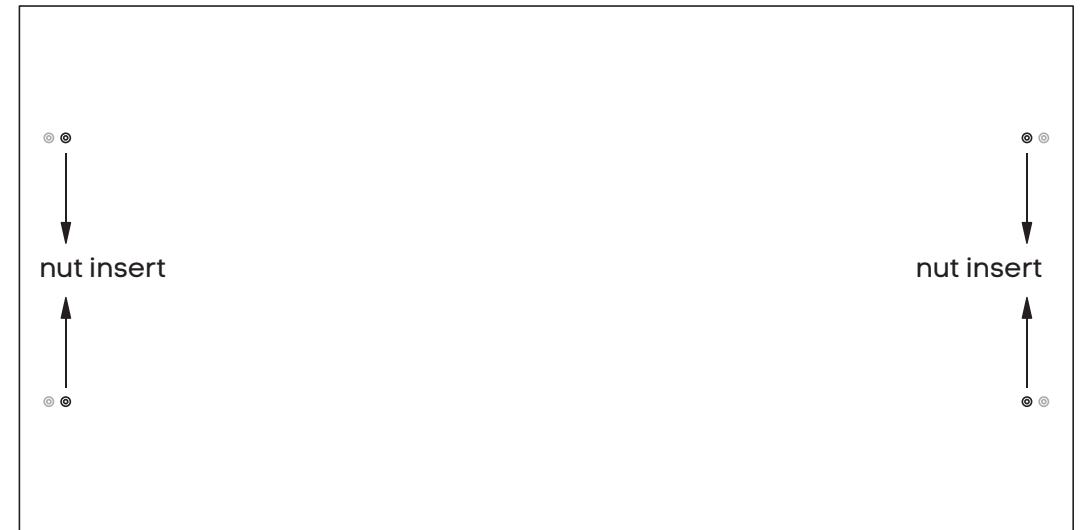

TABLE TOP  
BOTTOM VIEW



Place desktop on top of frame. Nut inserts in top will align with plastic joiner brackets using M6x30MM (I) sockets attached top to frame.