

Quadro A Leg Desk

Sizes:

1400x800

1600x800

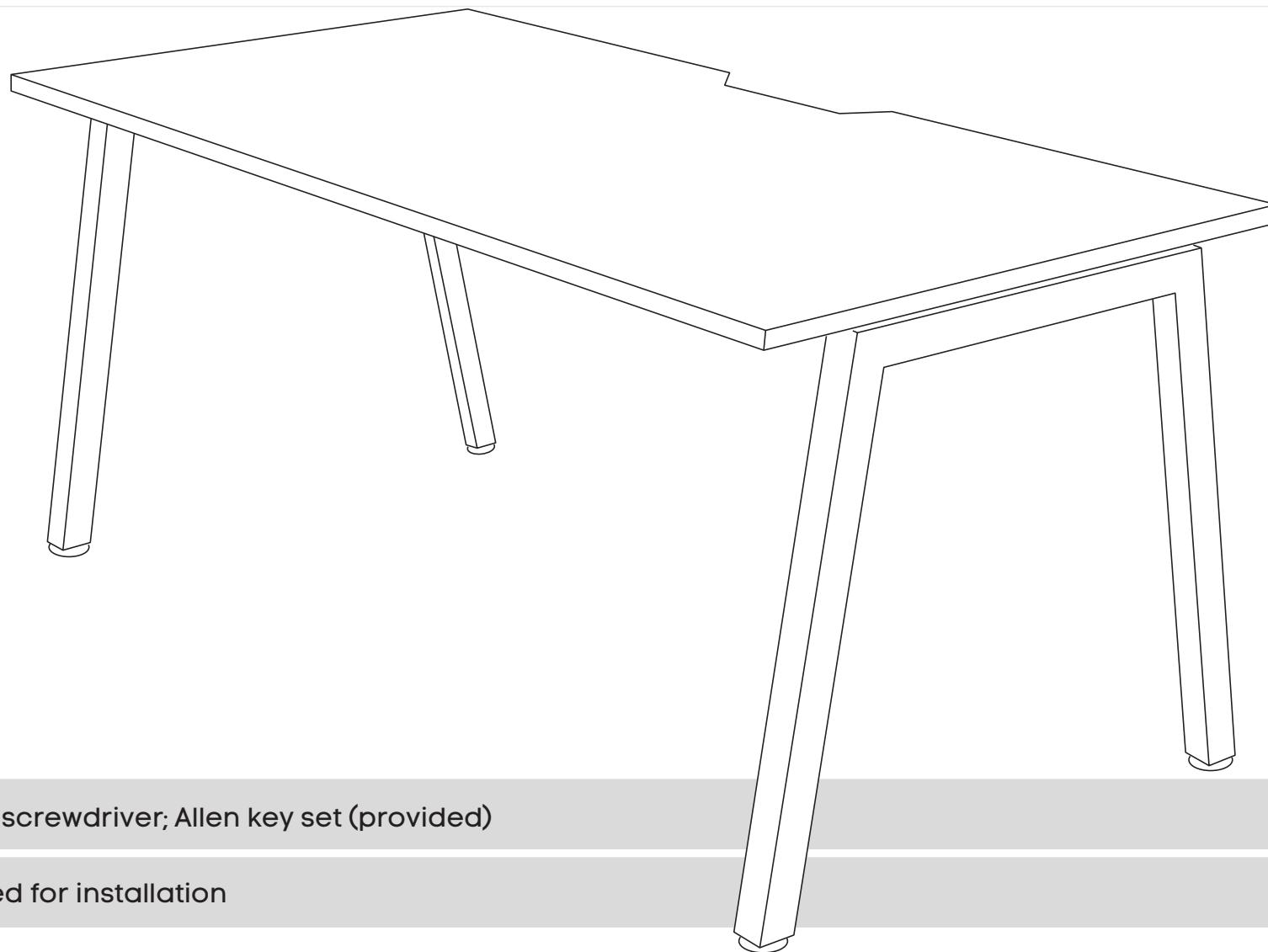

Tools Required: Power screwdriver; Allen key set (provided)

 2 persons required for installation

Need help!

Call us on **1300 527 665**

Quadro A Leg Desk

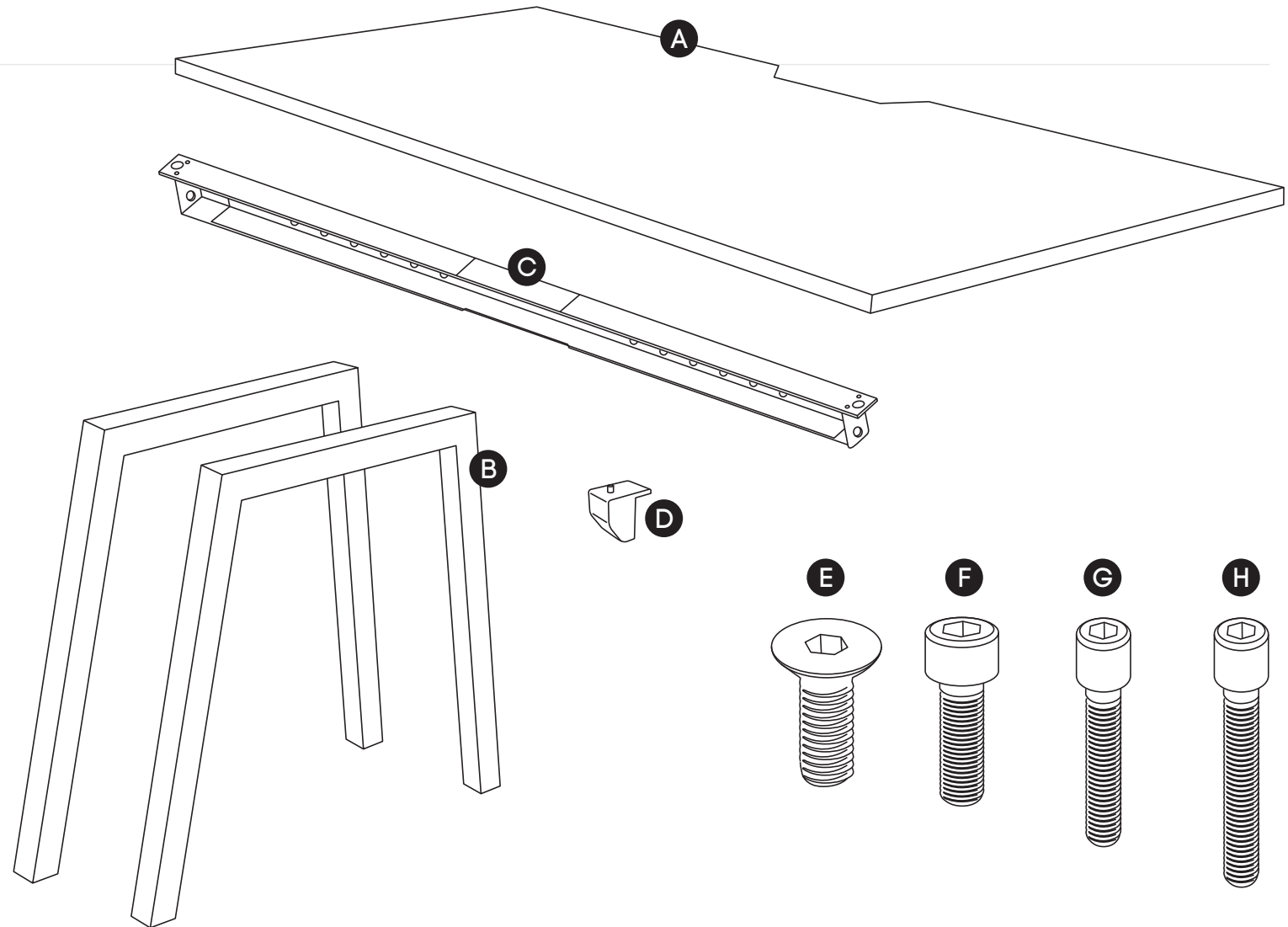

COMPONENTS

- A Table top x1
- B Legs Quadro A x2
- C Beam x1 *
- D Plastic bracket x4

SCREWS

- E M8x20MM CSK x2
- F M8x20MM Socket head x2
- G M6x20MM Socket head x4
- H M6x30MM Socket head x4

- I Allen key x2

* Colour of the beam is always black, regardless desk frame colour.

Quadro A Leg Desk



Using Allen Key provided, attach 2 plastic brackets per leg **(D)** (as per picture above) using M6x20MM **(G)** Socket head screw

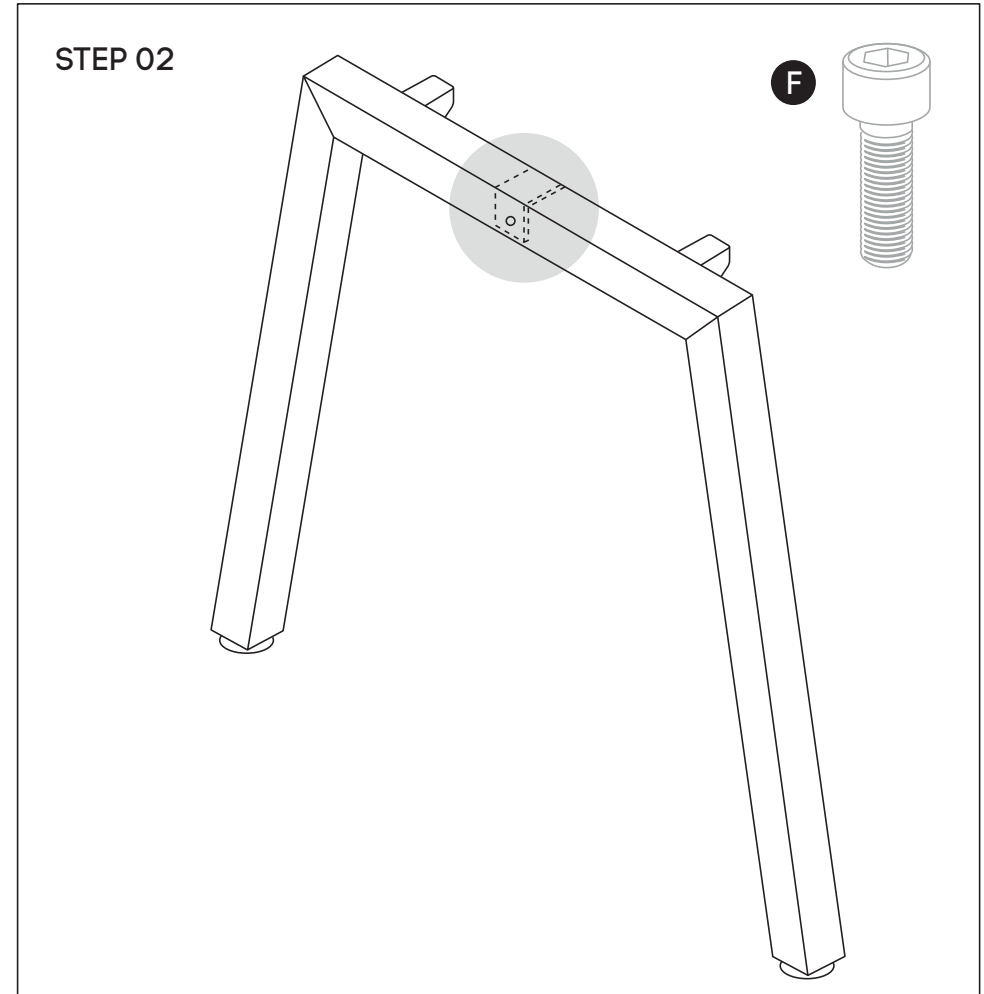

Using Allen Key provided, attach M8x20MM Socket head **(F)**-screw socket half way into leg for both legs **(B)**

Quadro A Leg Desk

STEP 03

Adjust extendable beam (C) to desired length using markers and secure beam at that length using screws provided

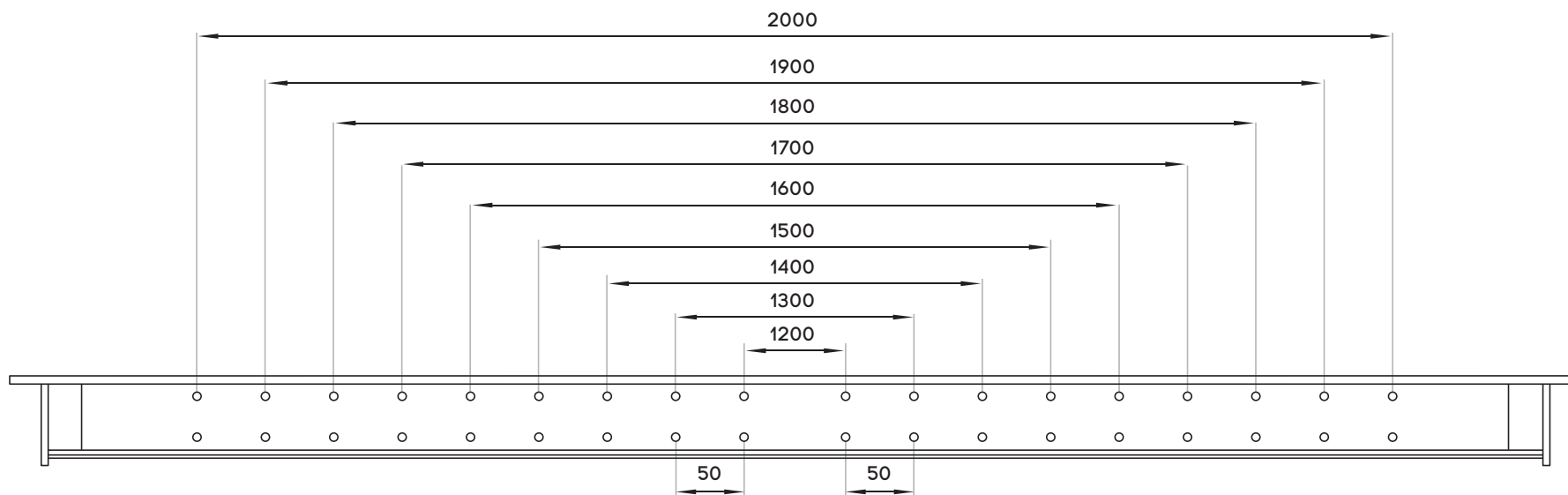
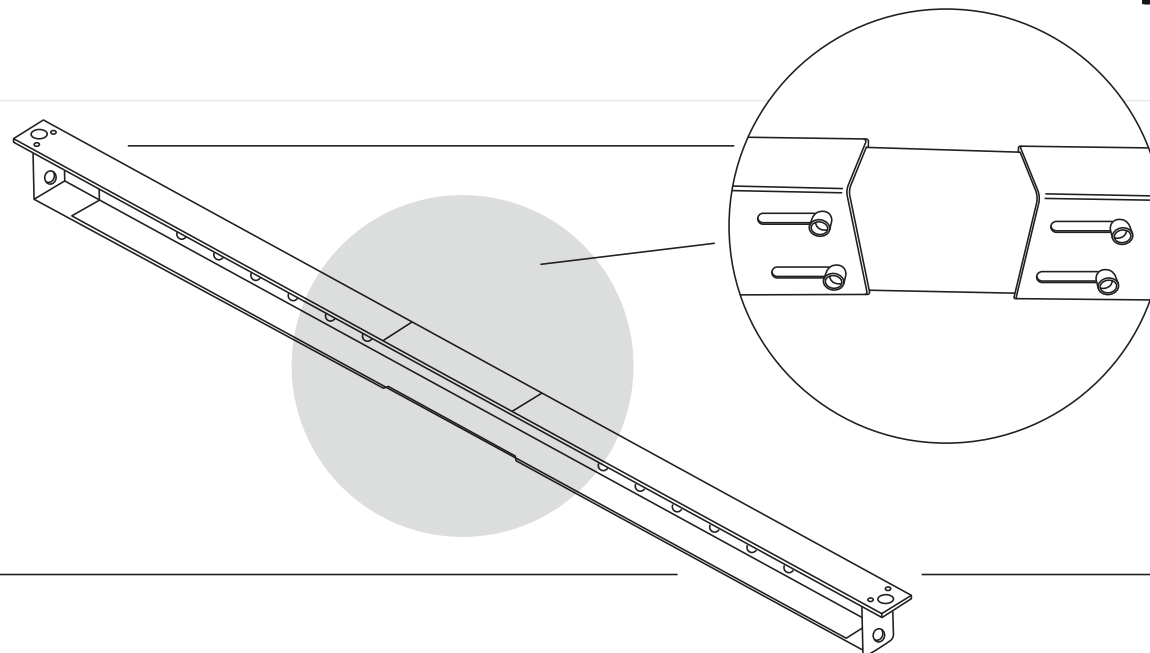

Quadro A Leg Desk

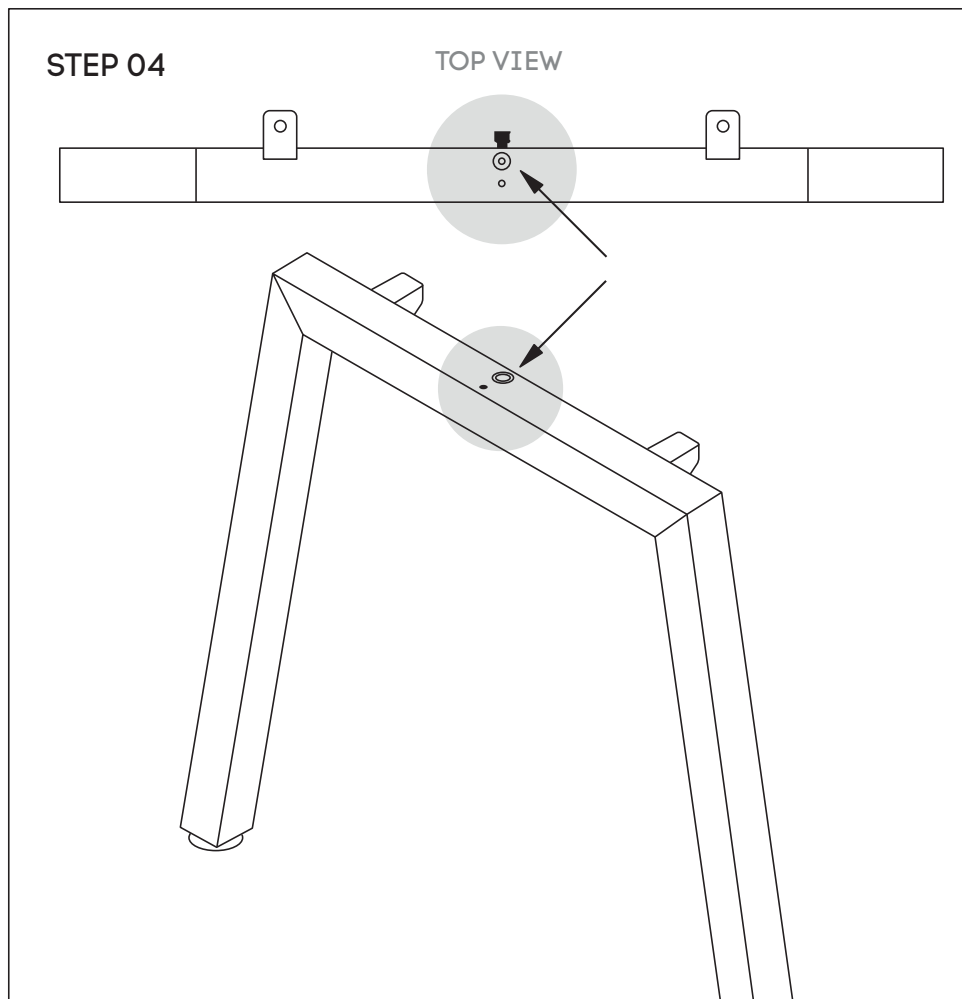

Attach beam (C) to legs (B) using nut insert in legs. See point attached

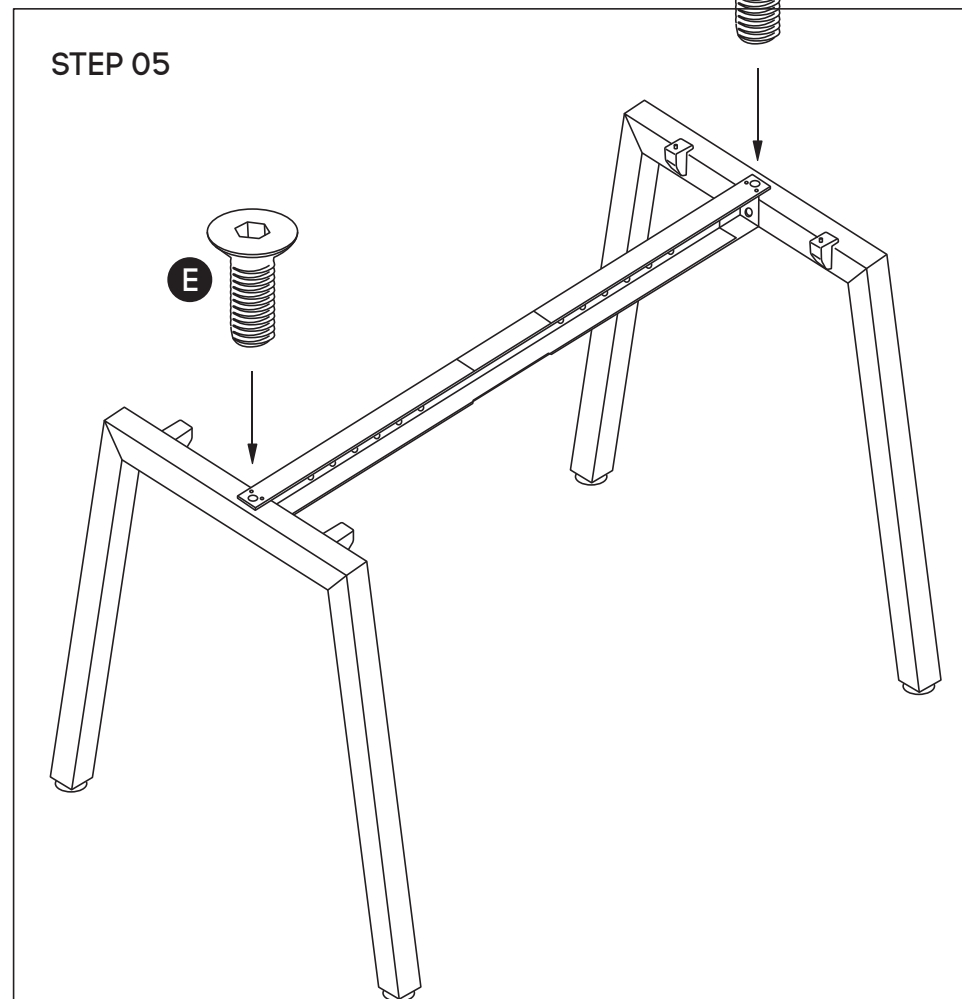

Frame looks like this. Using Allen Key, attach beam (C) with Socket (E)

Need help! Call us on **1300 527 665**

Quadro A Leg Desk

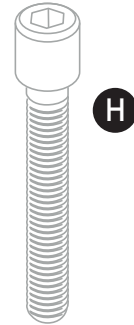
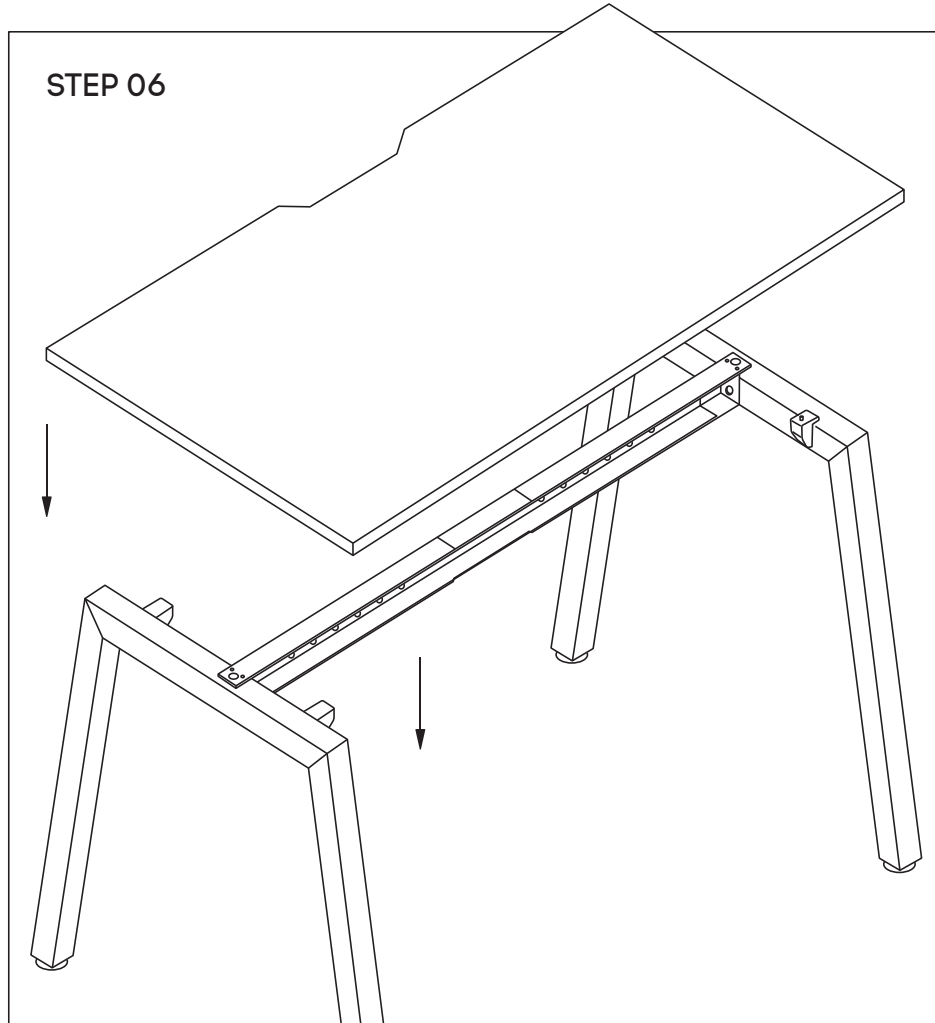
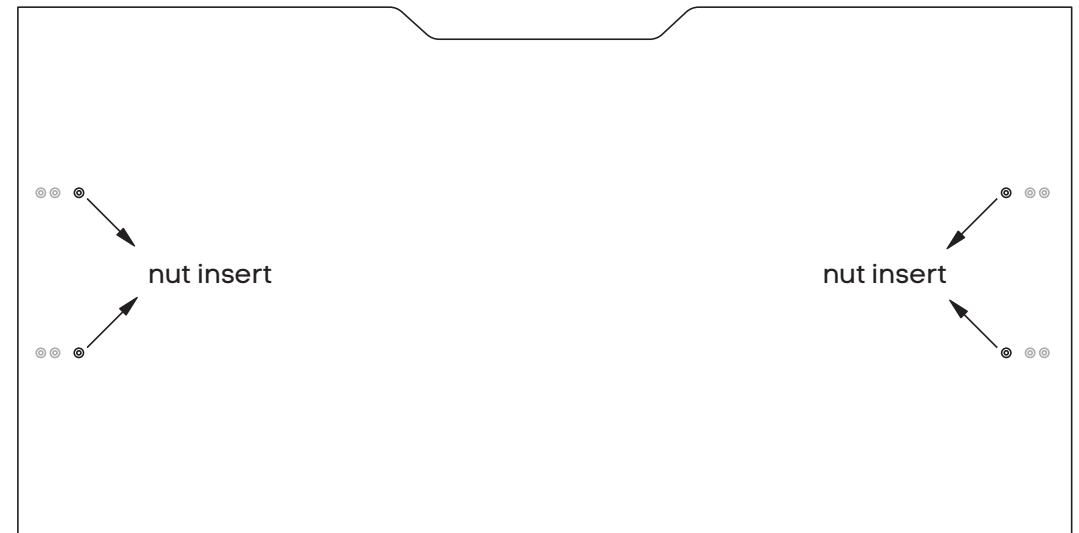

TABLE TOP
BOTTOM VIEW



Place desktop on top of frame - with cutout at the back of the desk. Nut inserts in top will align with plastic joiner brackets using M6x30MM (H) sockets attached top to frame.