

Quadro A Leg Desk

Sizes:

1200x800

1800x800

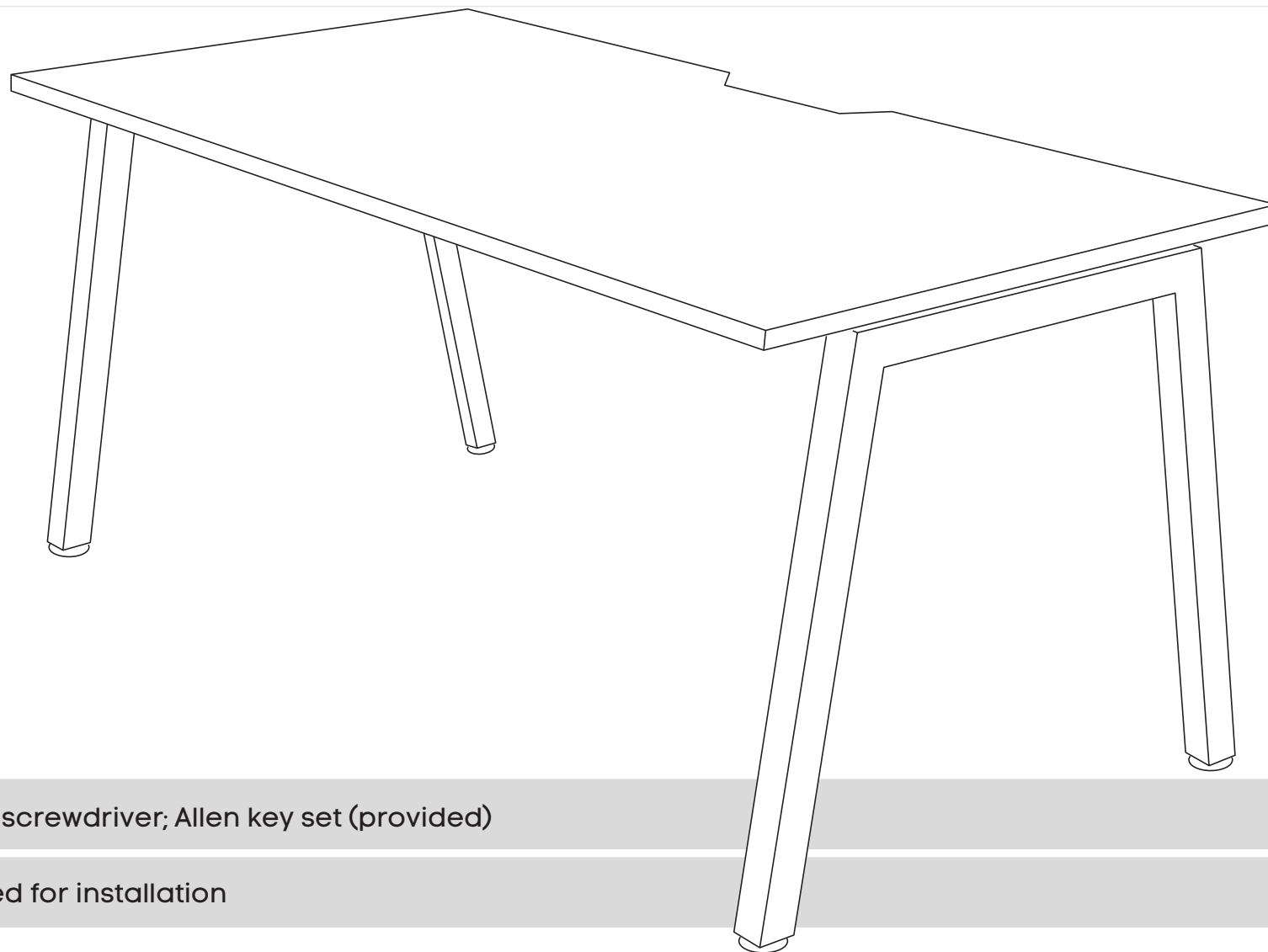

Tools Required: Power screwdriver; Allen key set (provided)

 2 persons required for installation

Need help!

Call us on **1300 527 665**

Quadro A Leg Desk

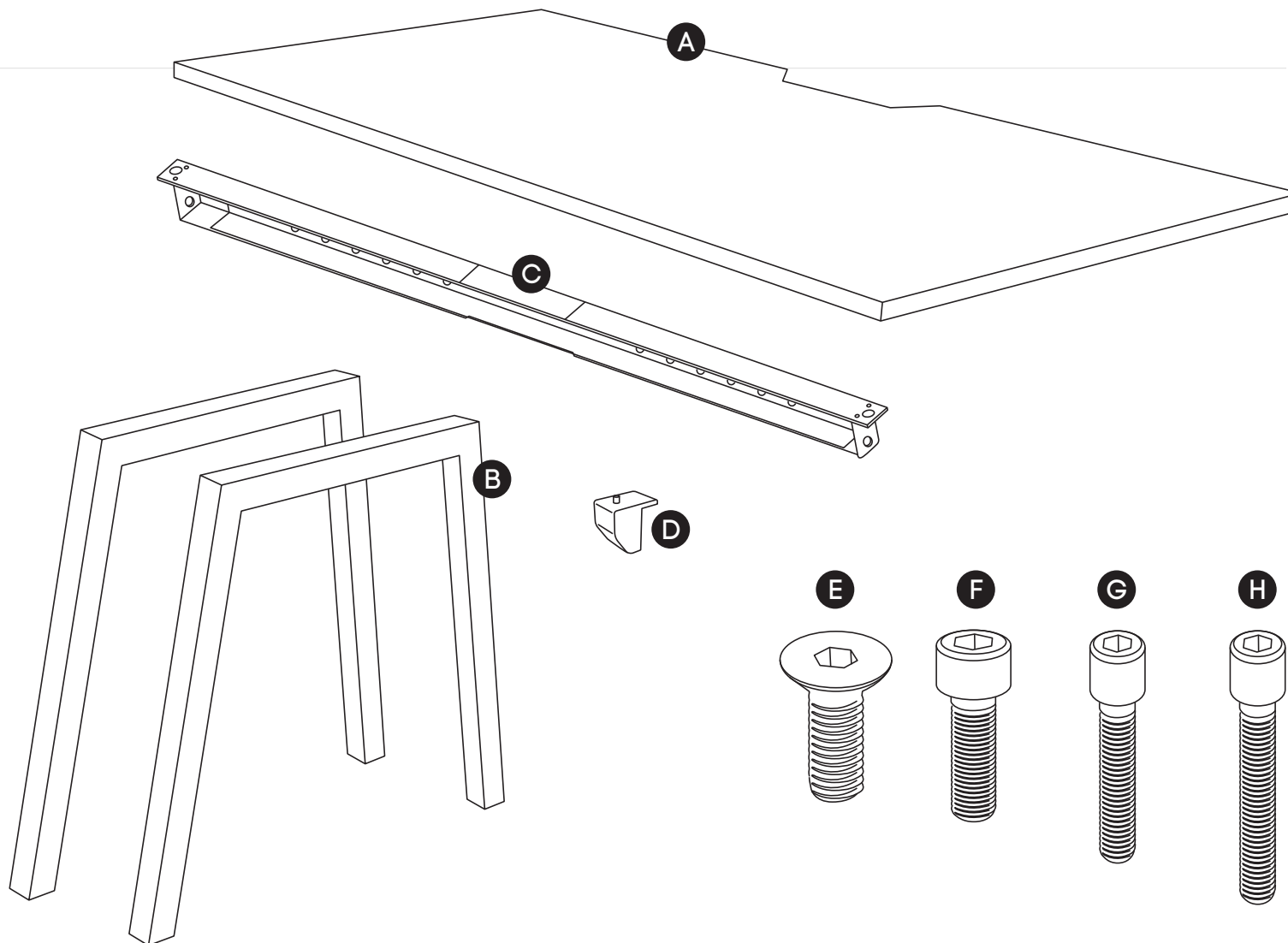

COMPONENTS

- A Table top x1
- B Legs Quadro A x2
- C Beam x1 *
- D Plastic bracket x4

SCREWS

- E M8x20MM CSK x2
- F M8x20MM Socket head x2
- G M6x20MM Socket head x4
- H M6x30MM Socket head x4

I Allen key x2

* Colour of the beam is always black, regardless desk frame colour.

Need help! Call us on **1300 527 665**

Quadro A Leg Desk

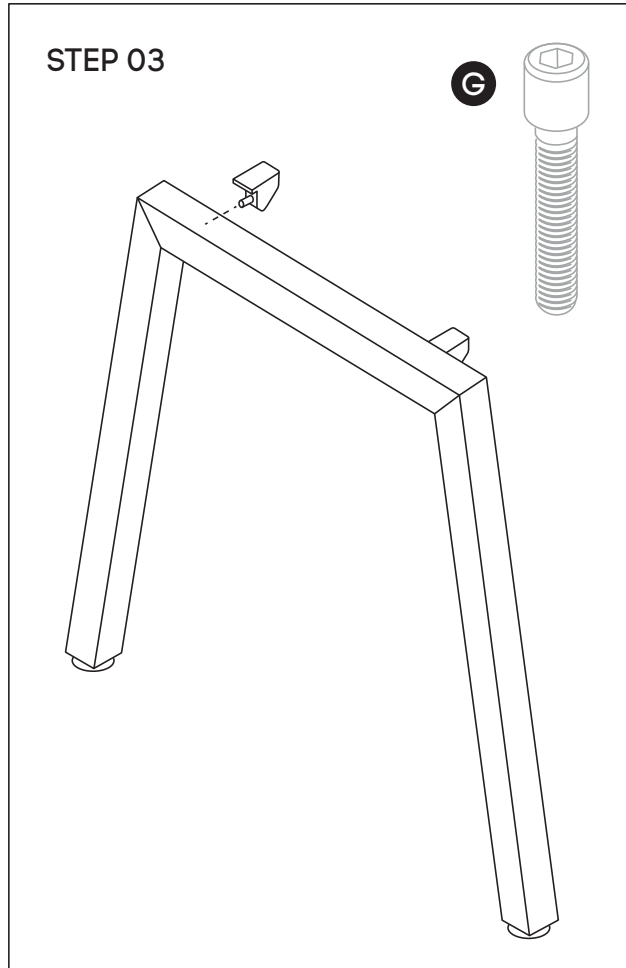

Using Allen Key provided, attach 2 plastic brackets per leg **(D)** (as per picture above) using M6x20MM **(G)** Socket head screw

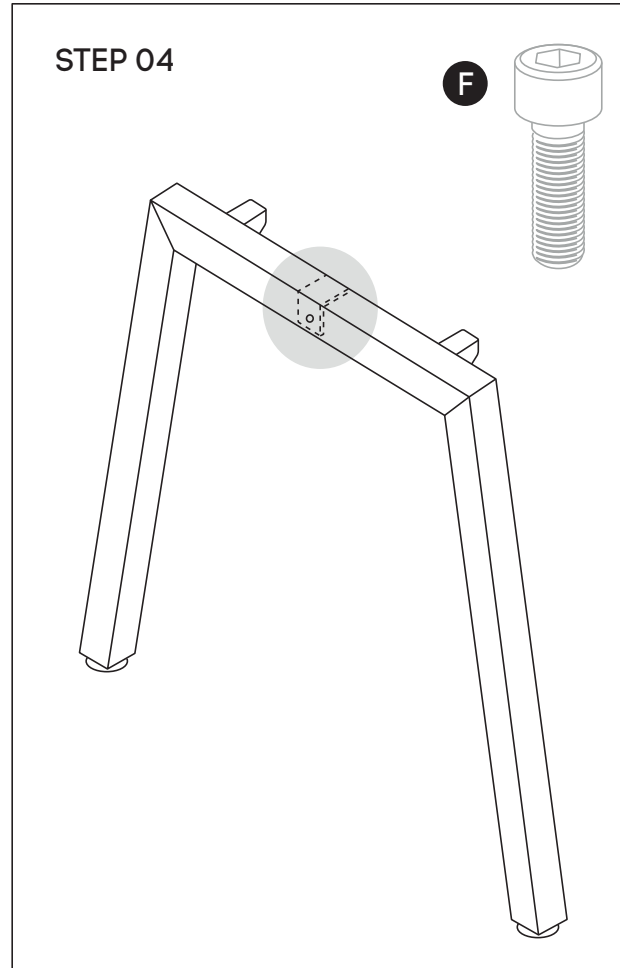

Using Allen Key provided, attach M8x20MM Socket head **(F)**- screw socket half way into leg for both legs **(B)**

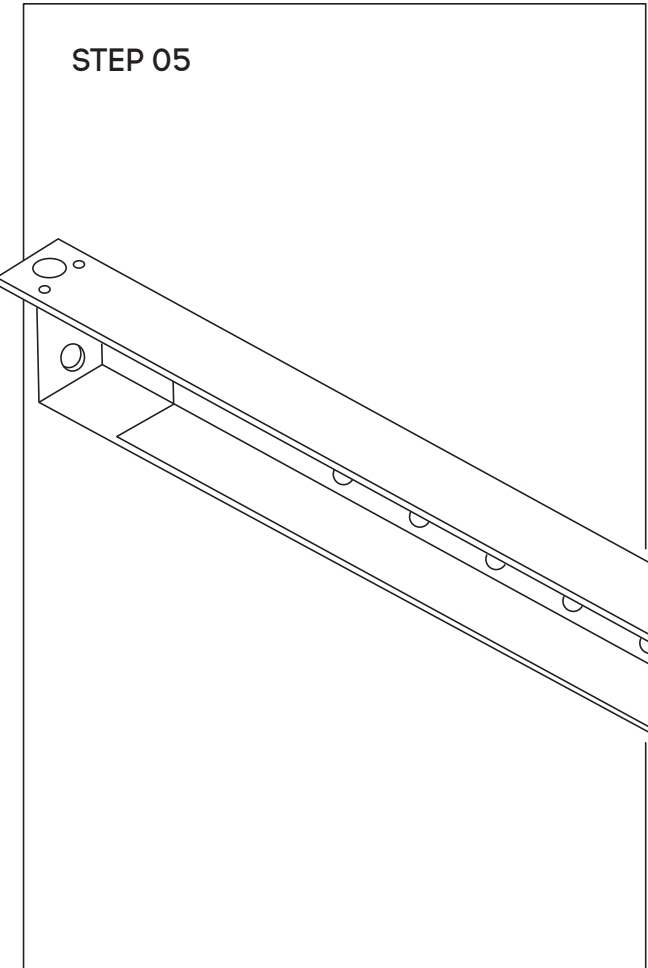

Use fixed beam **(C)** and secure beam using screws provided to suit desk

Quadro A Leg Desk

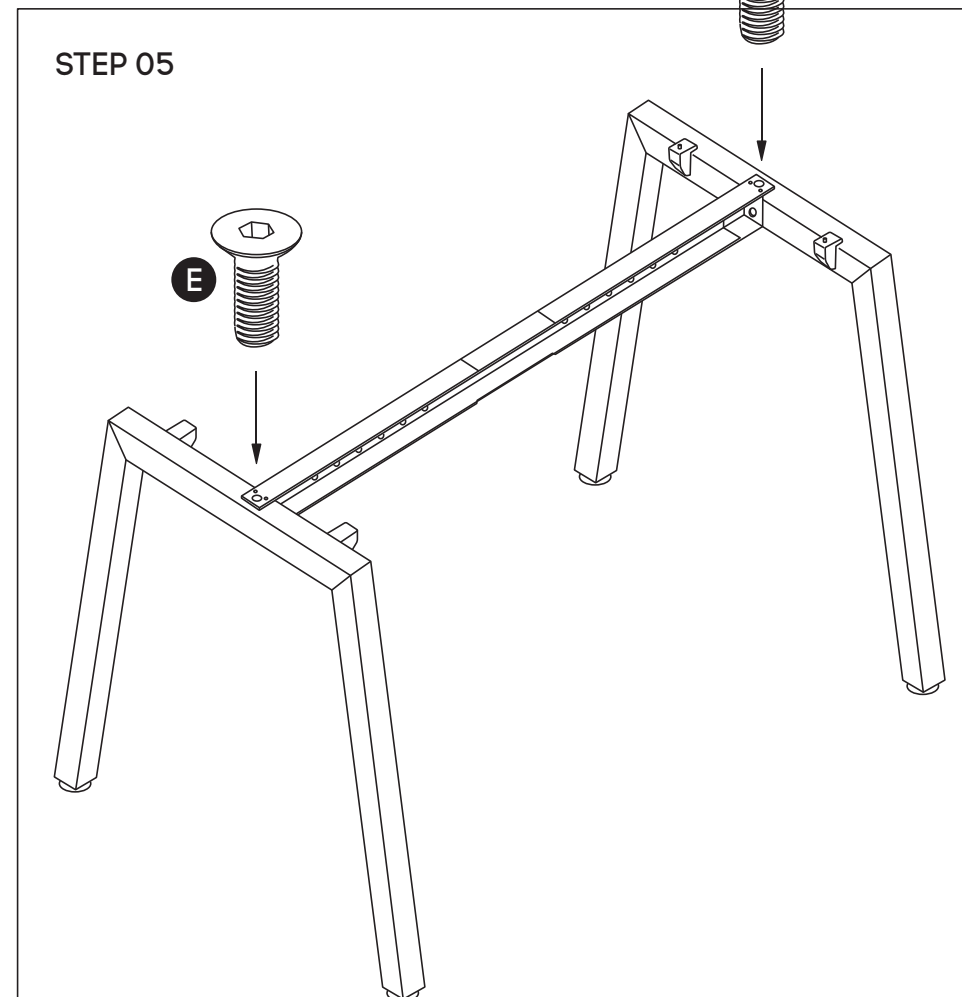
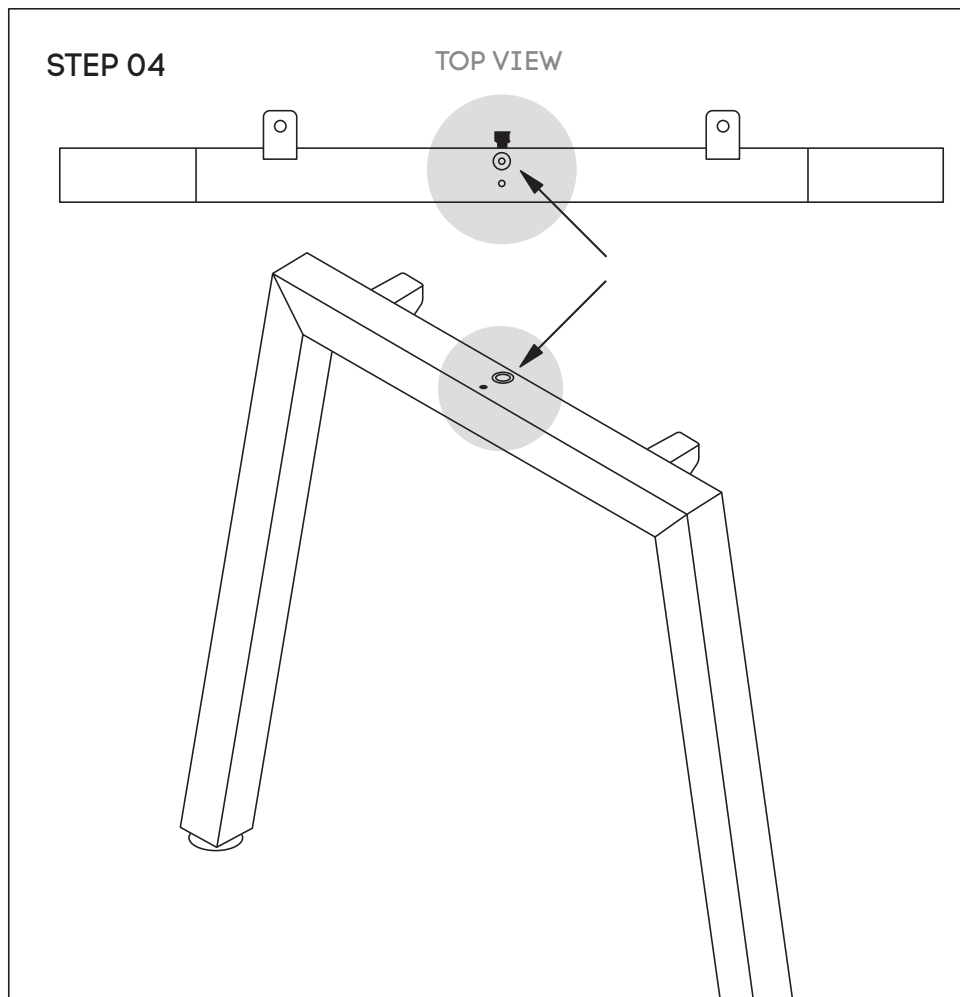

Attach beam **(C)** to legs **(B)** using nut insert in legs.
See point attached

Frame looks like this. Using Allen Key, attach beam **(C)** with Socket **(E)**

Need help!

Call us on **1300 527 665**

Quadro A Leg Desk

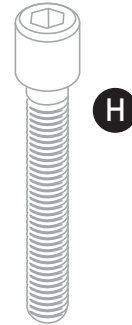
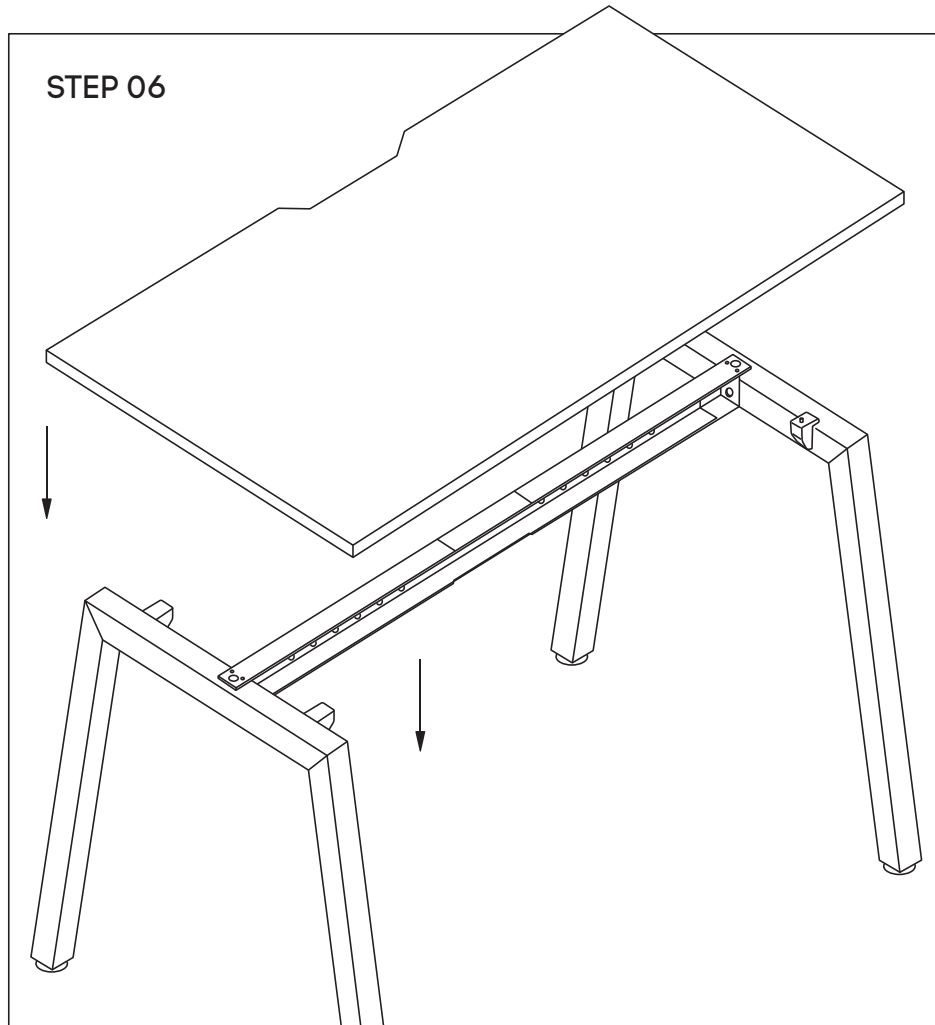

H

TABLE TOP
BOTTOM VIEW

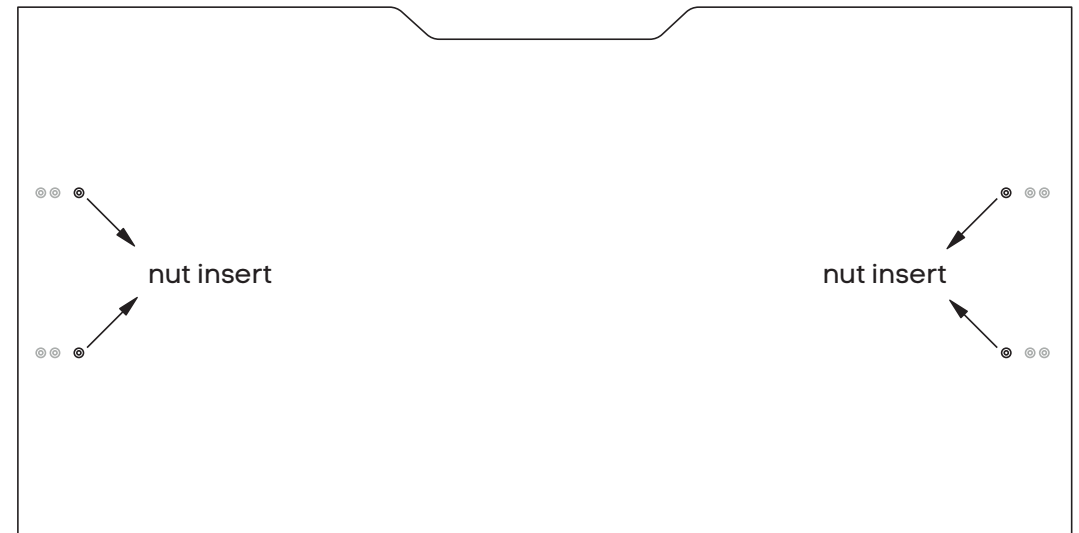

Place desktop on top of frame - with cutout at the back of the desk. Nut inserts in top will align with plastic joiner brackets using M6x30MM (H) sockets attached top to frame.