

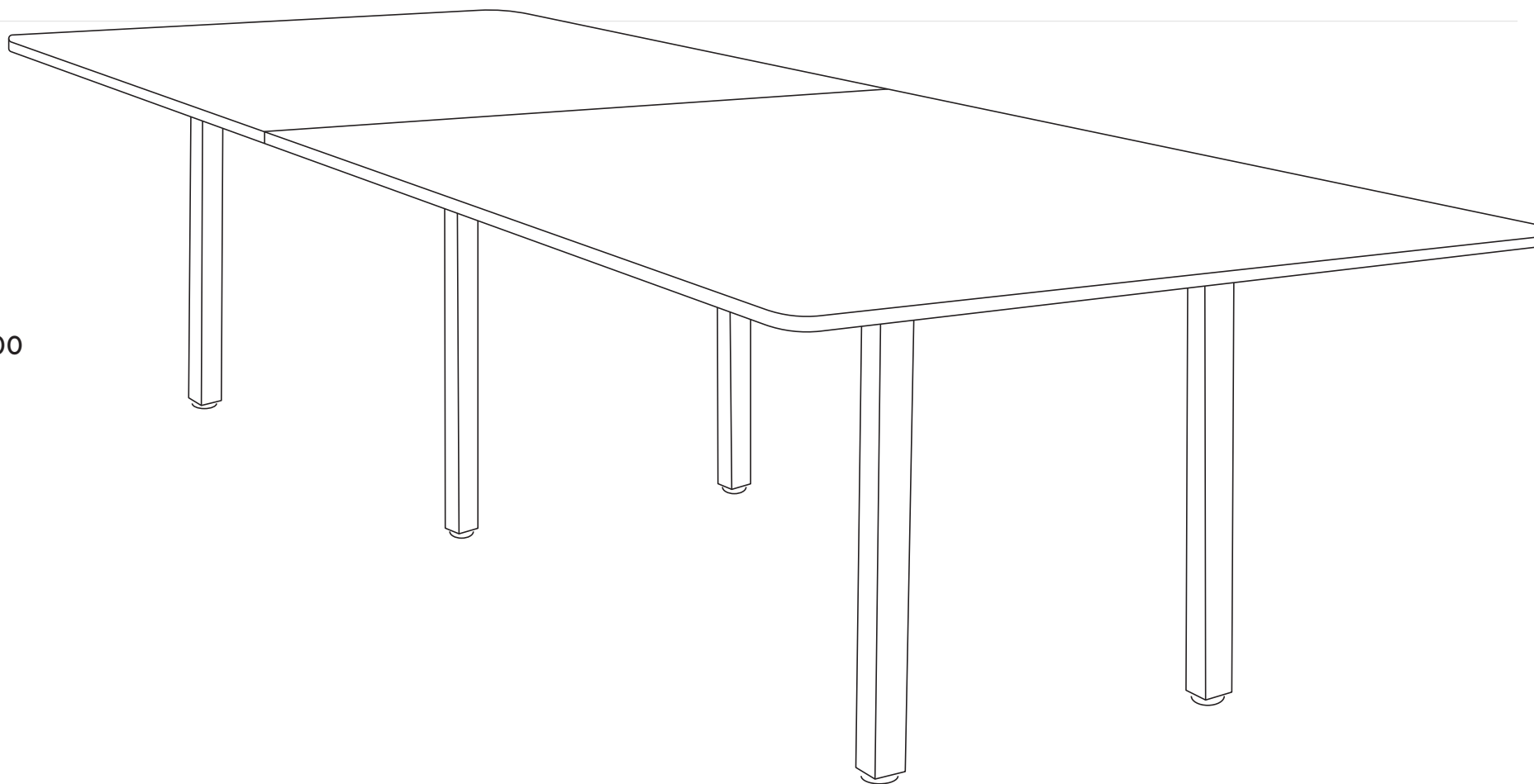

Quadro Square Boardroom table

jason.l



Sizes:
3200x1100

Tools Required: Power screwdriver; Allen key set (provided)

 2 persons required for installation

Need help!

Call us on **1300 527 665**

Quadro Square Boardroom table

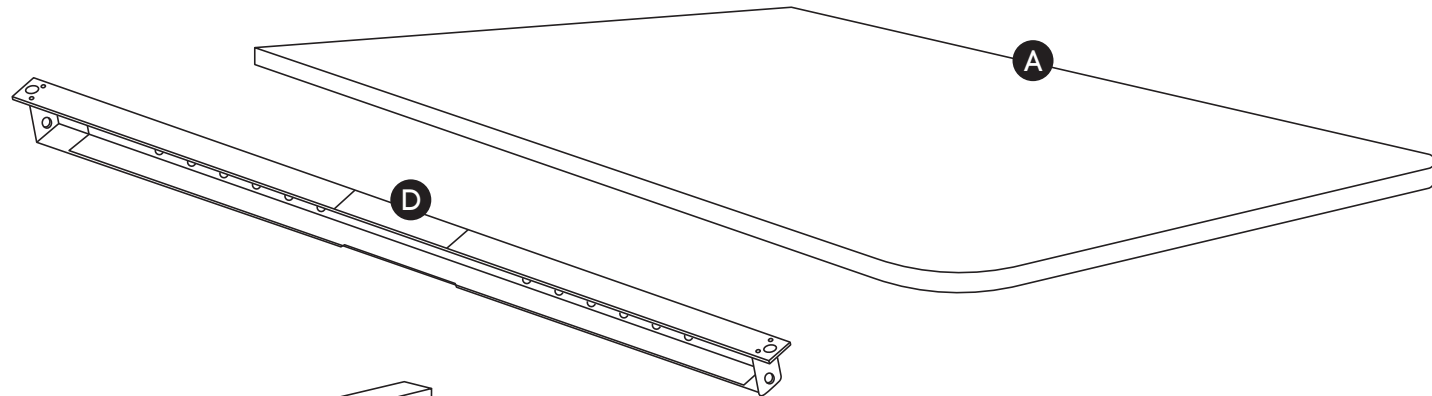

COMPONENTS

- A Table top x2
- B Leg Quadro Square x2
- C Connector frame x1
- D Beam x2 *
- E Plastic bracket x8

SCREWS

- F M8x20MM CSK x4
- G M8x20MM Socket head x4
- H M6x20MM Socket head x8
- I M6x30MM Socket head x8

- J Allen key x2

* Colour of the beam is always black, regardless desk frame colour.

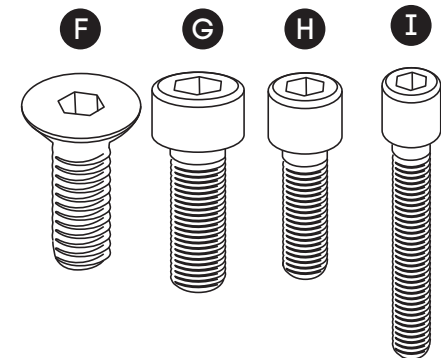
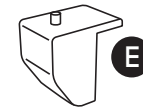
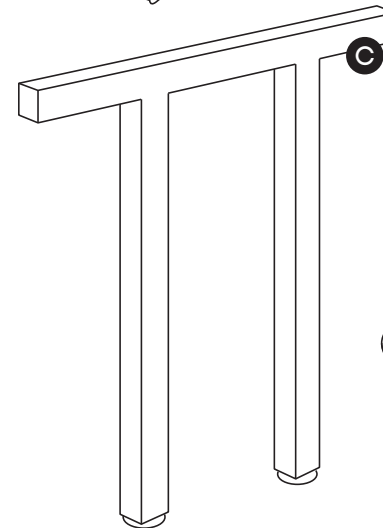
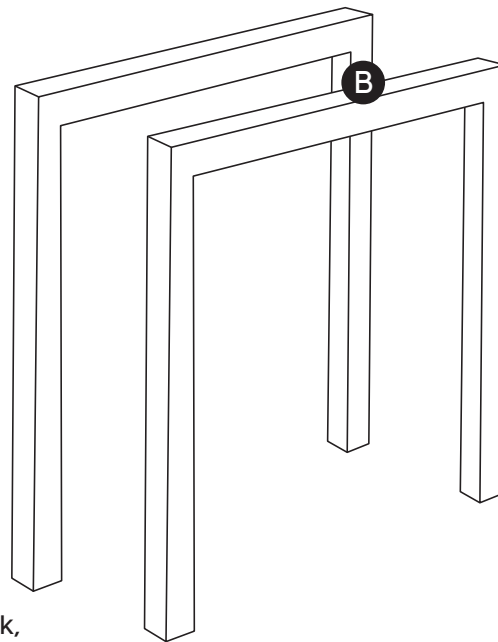

Quadro Square Boardroom table

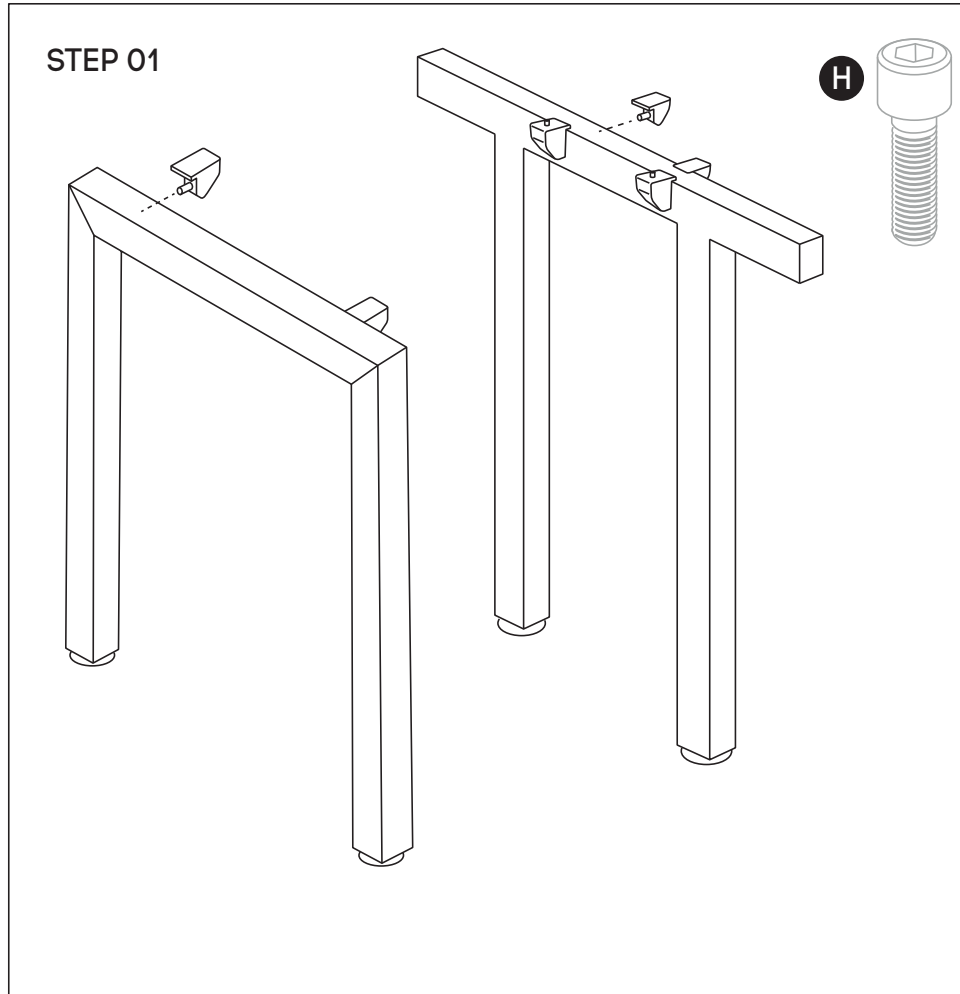

Using Allen Key provided, attach 2 plastic brackets per leg **(E)** (as per picture above) using M6x20MM **(H)** Socket head screw. Do the same with Connector frame **(C)**.

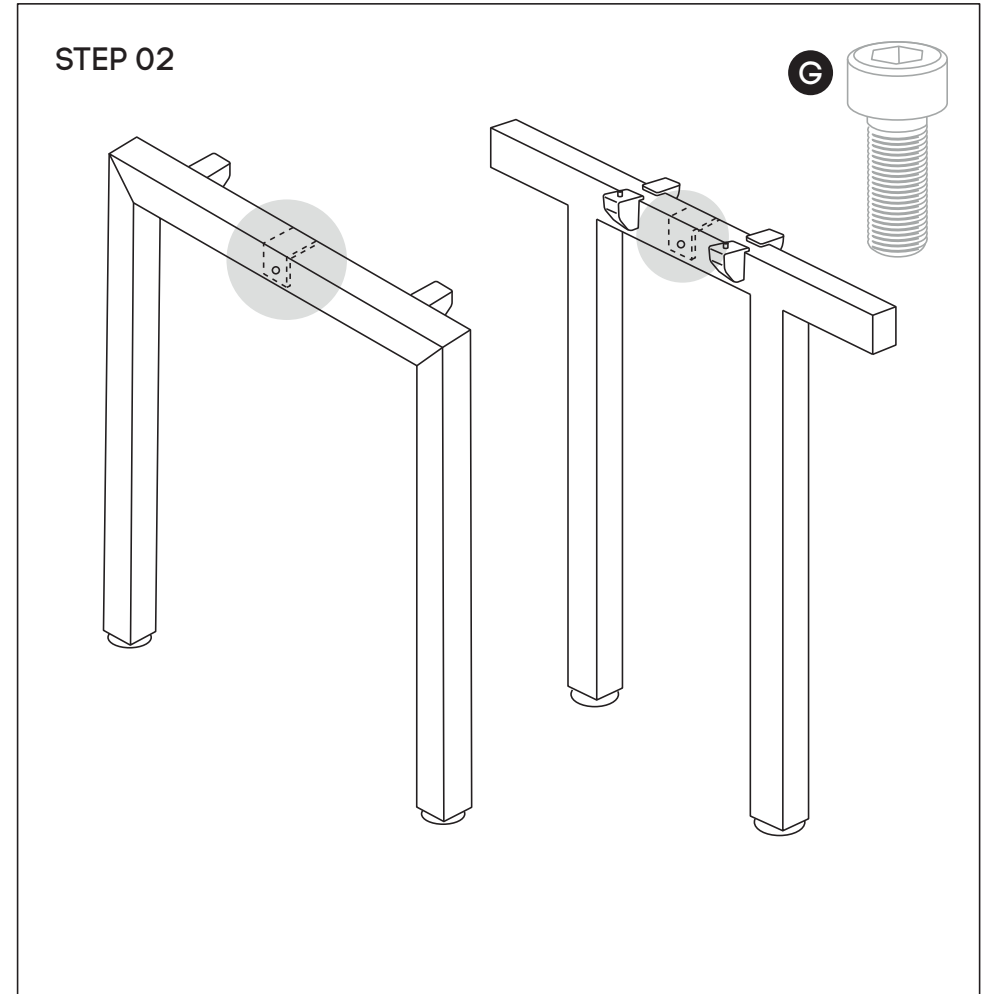

Using Allen Key provided, attach M8x20MM Socket head **(G)**-screw socket half way into leg for both legs **(B)** and into Connector frame **(C)**.

Need help!

Call us on **1300 527 665**

Quadro Square Boardroom table

STEP 03

Adjust extendable beam to desired length using markers and secure beam at that length using screws provided

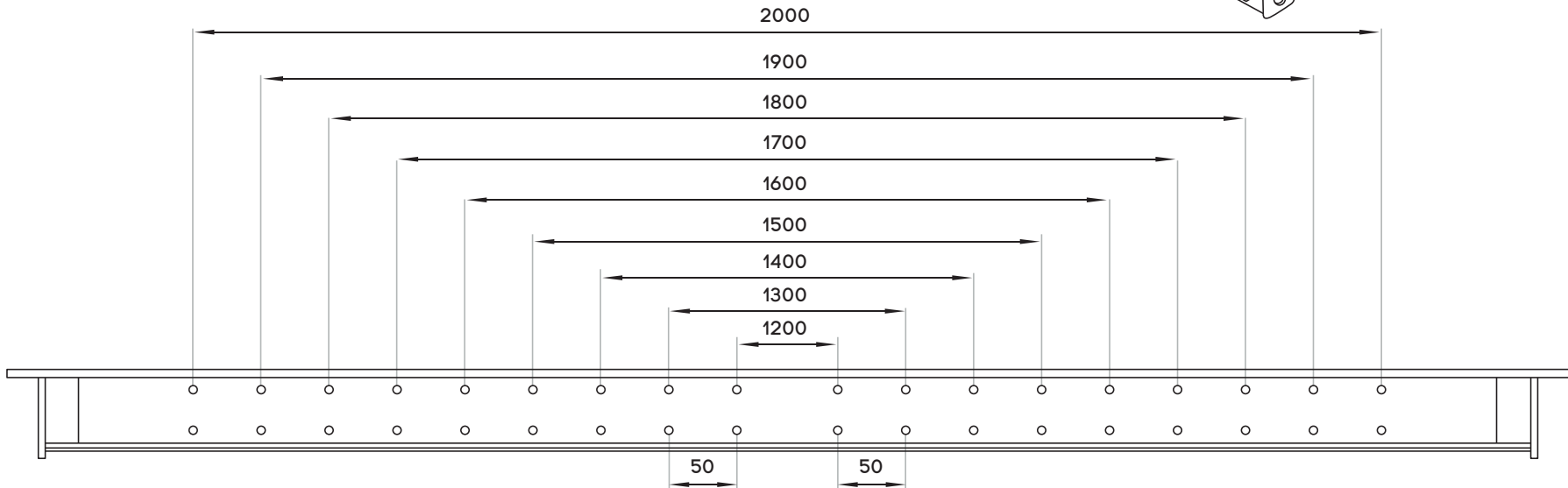
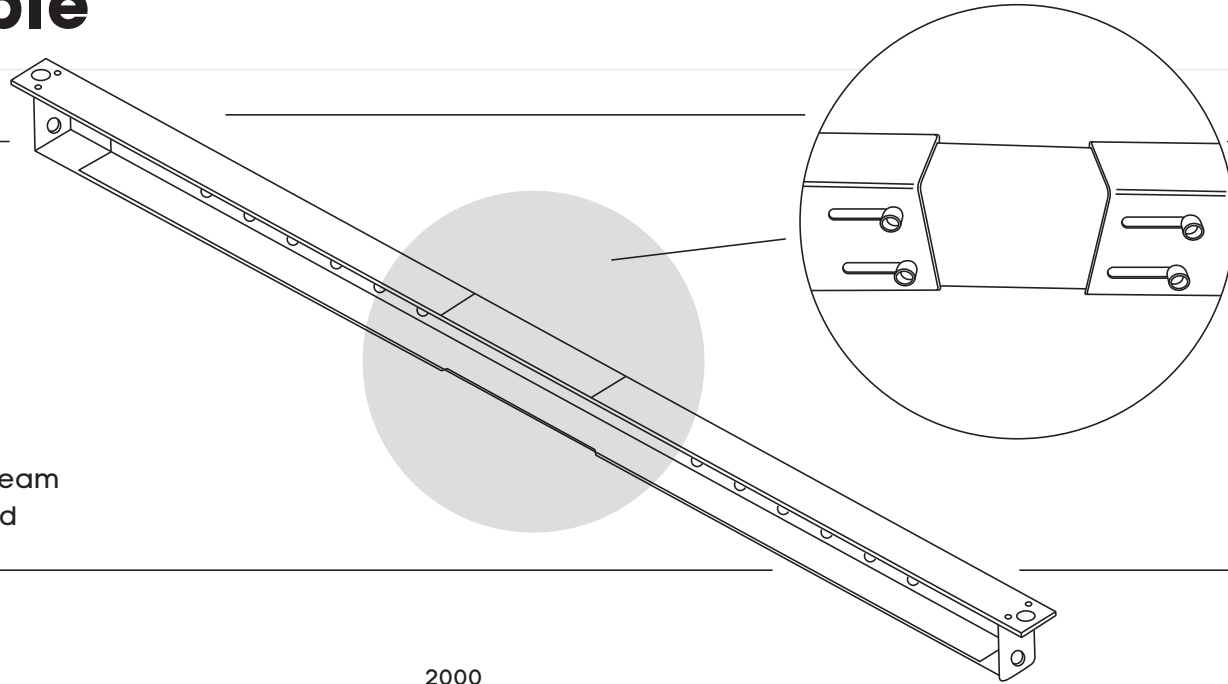

Need help!

Call us on **1300 527 665**

Quadro Square Boardroom table

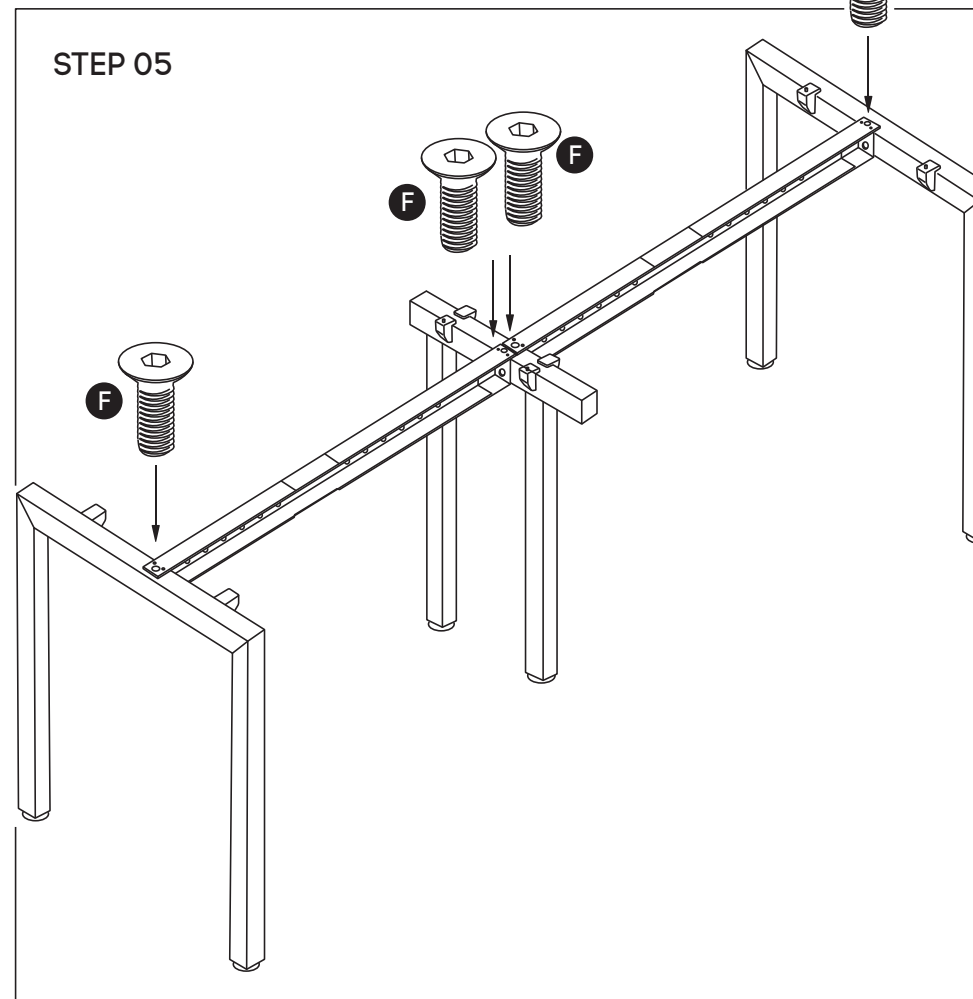
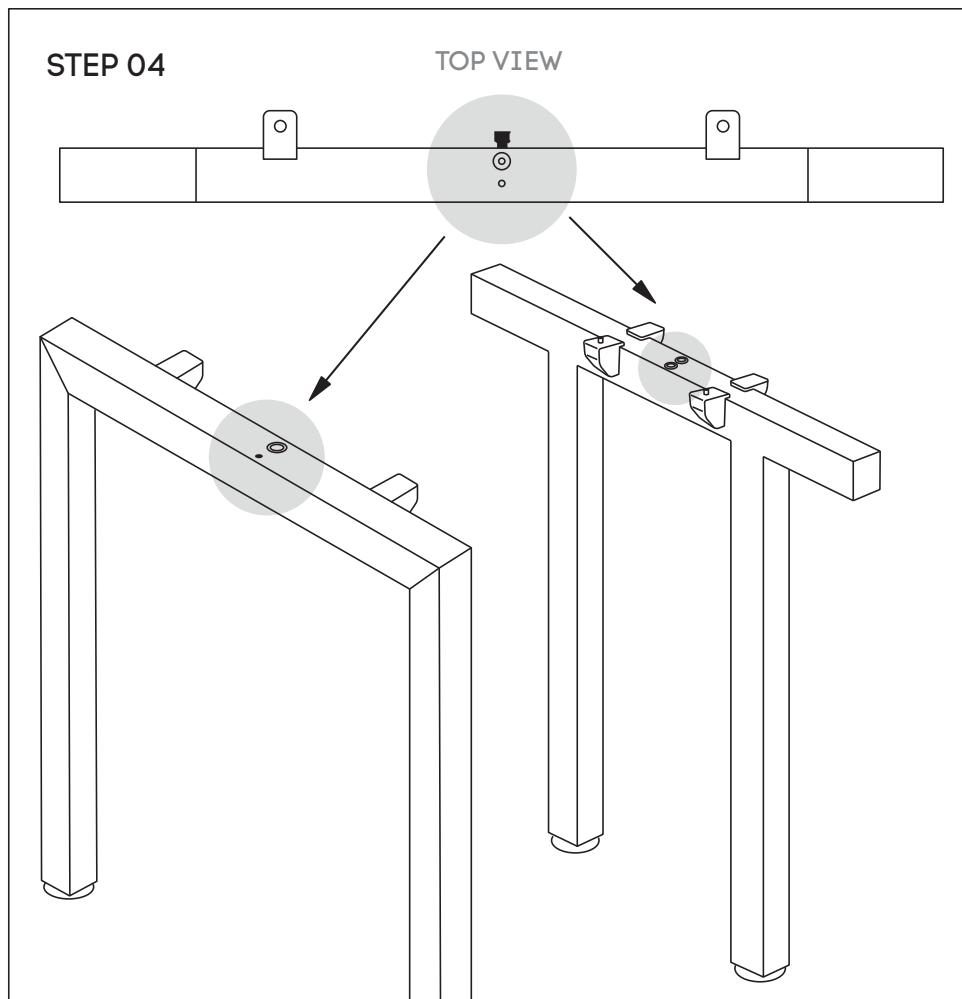

Attach beam **(D)** to legs **(B)** and Connector frame **(C)** using nut insert in legs. See point attached

Frame looks like this. Using Allen Key, attach beam **(D)** with Socket **(F)**

Need help!

Call us on **1300 527 665**

Quadro Square Boardroom table

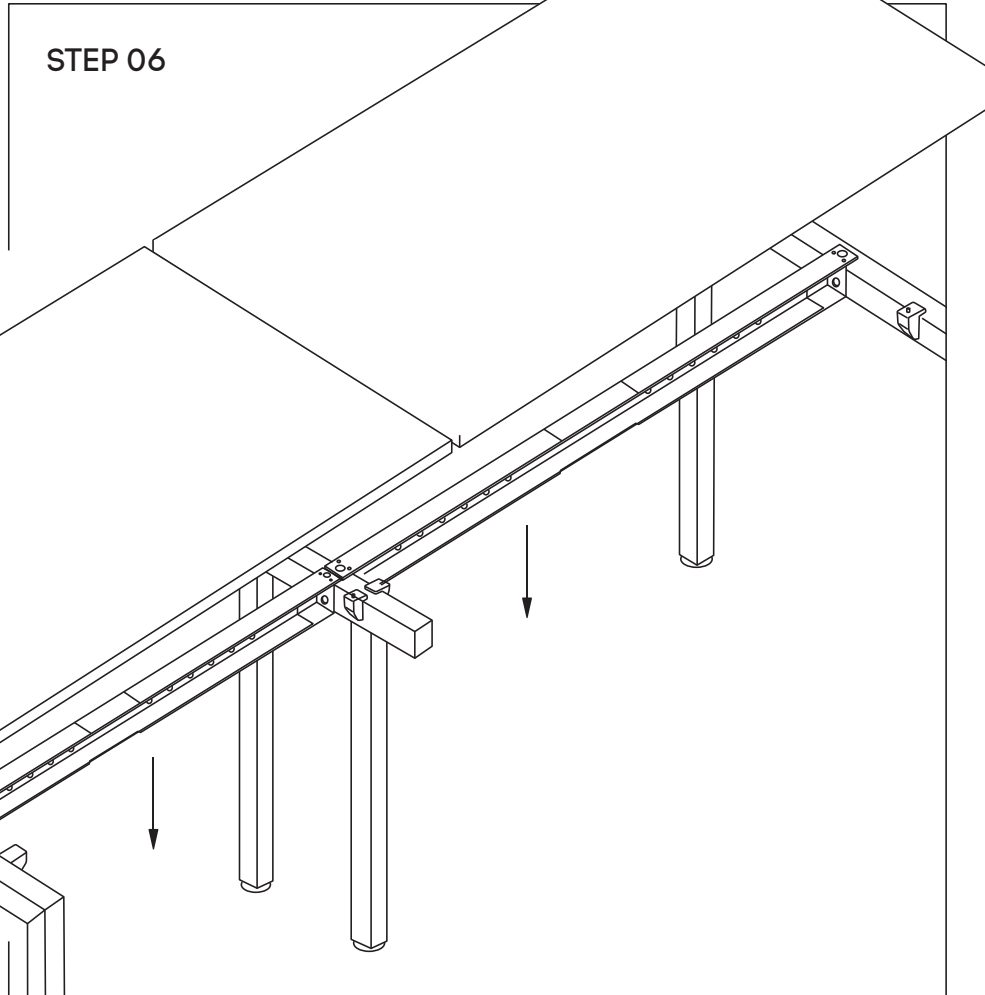

Place the desktop on top of the frame. Please place the legs ideally indented around 300mm from each end left and right of the Tops, Place the legs centred at the same distance equally from the front and back of the top.

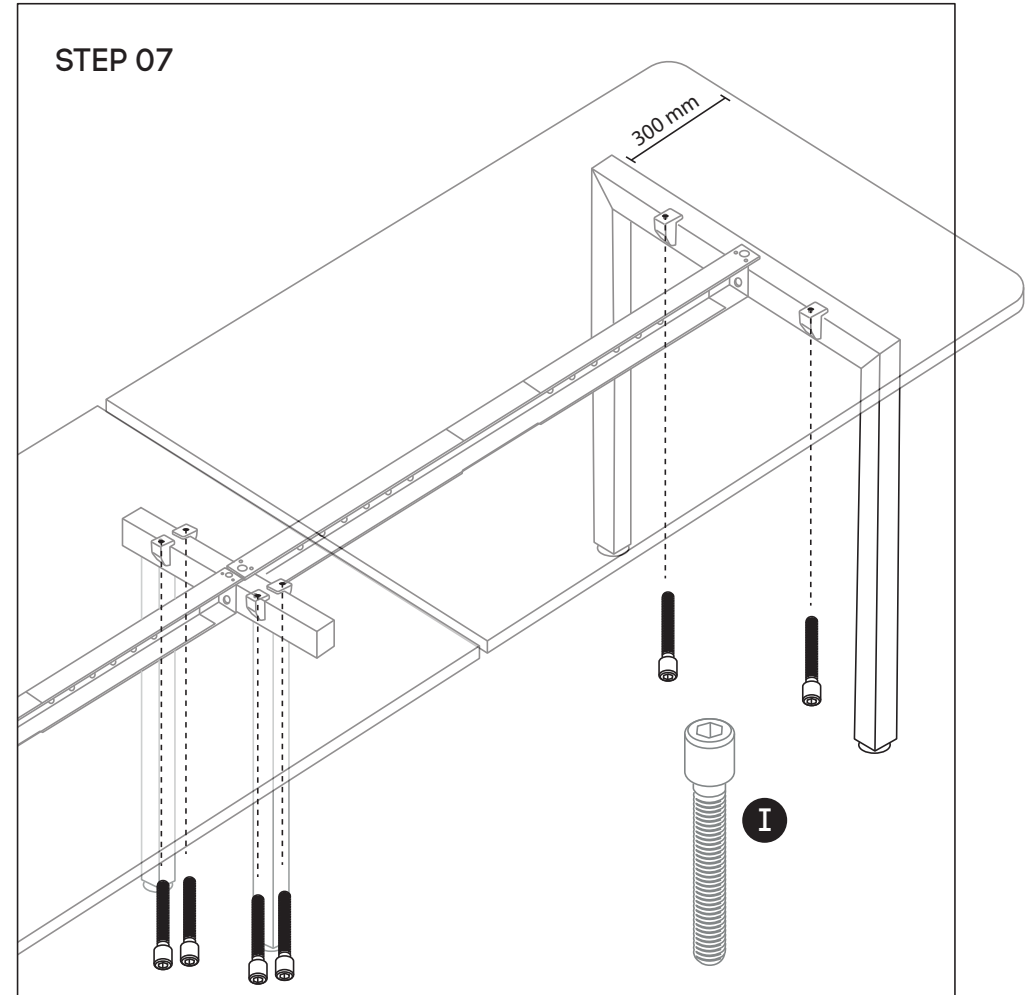

Please tighten M6x30MM Socket head (I) through the plastic brackets into the underneath of the tops.

Need help!

Call us on **1300 527 665**