

ASSEMBLY INSTRUCTIONS

Quadro Wood A

3P Run workstation

Sizes: 1200x700, 1400x700, 1600x700, 1800x700 mm

www.jasonl.com.au

Need help!

Call us on
1300 527 665

jason.l
your office furniture mate

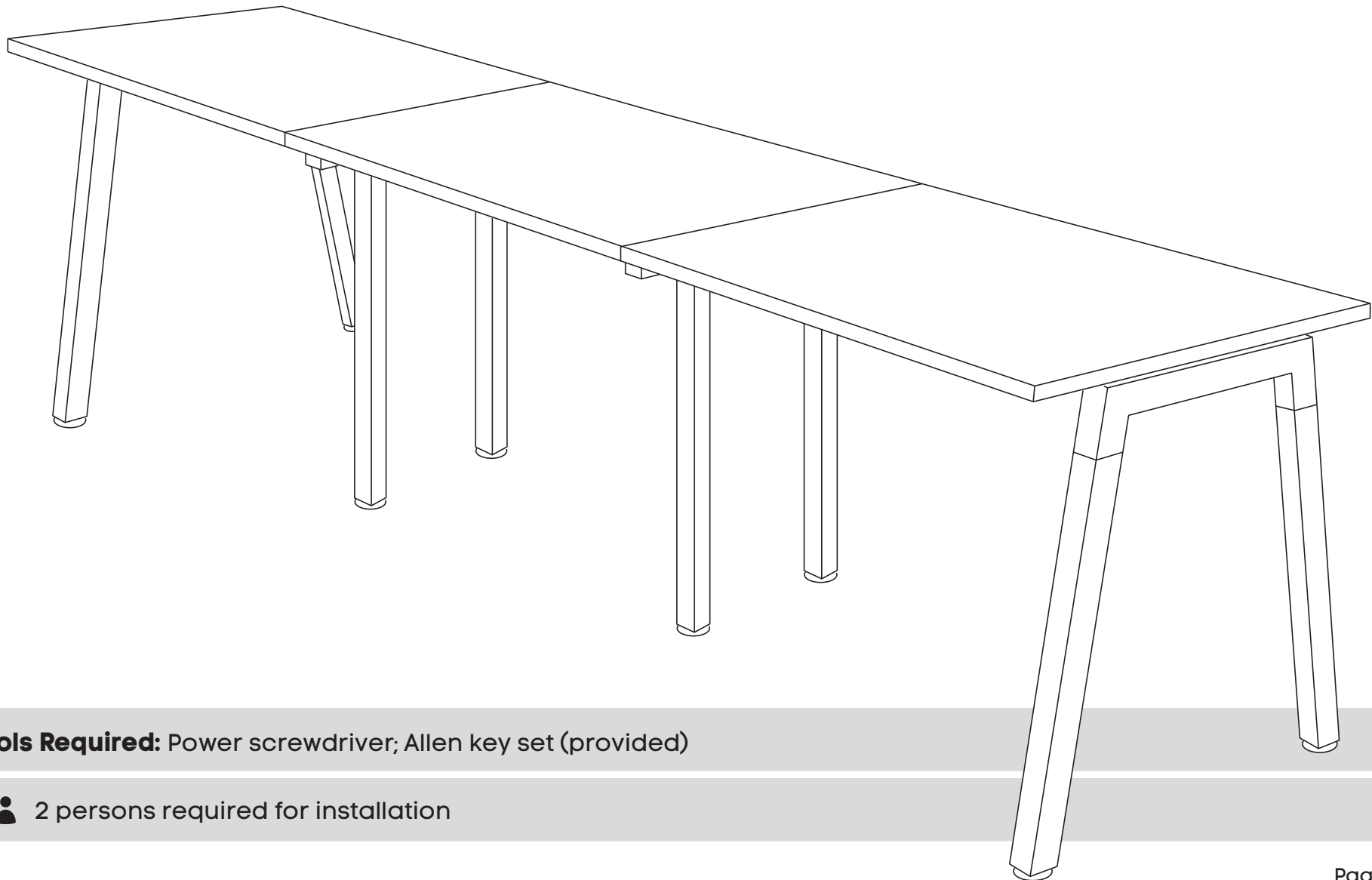

Tools Required: Power screwdriver; Allen key set (provided)

 2 persons required for installation

ASSEMBLY INSTRUCTIONS

Quadro Wood A

3P Run workstation

www.jasonl.com.au

Need help!

Call us on
1300 527 665

jason.l
your office furniture mate



Sizes: 1200x700, 1400x700, 1600x700, 1800x700 mm

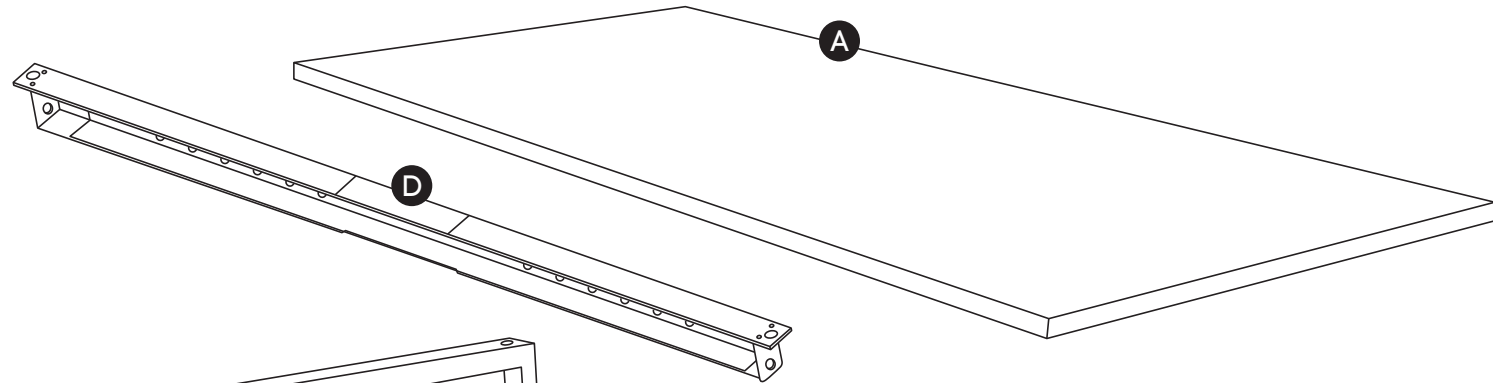

COMPONENTS

- A Table top x3
- B Leg Quadro Wood A x2
- C Connector frame x2
- D Beam x3 *
- E Plastic bracket x12

SCREWS

- F M8x20MM CSK x6
- G M8x20MM Socket head x6
- H M6x20MM Socket head x12
- I M6x30MM Socket head x12
- J M6x30mm Mushroom head screw x4

- K Allen key x2

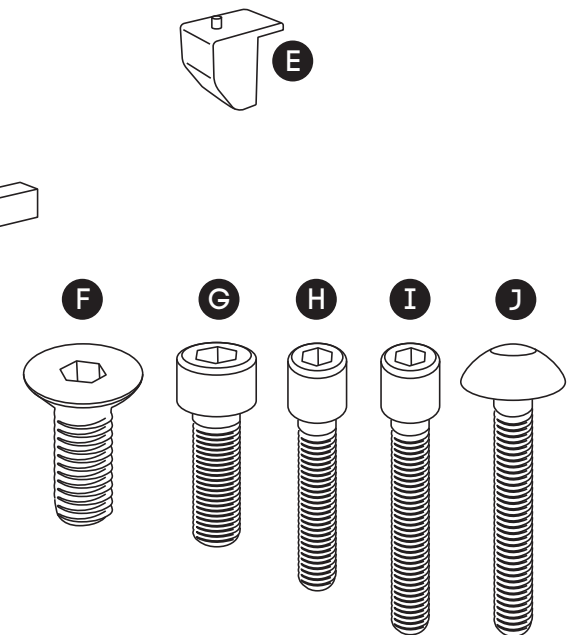
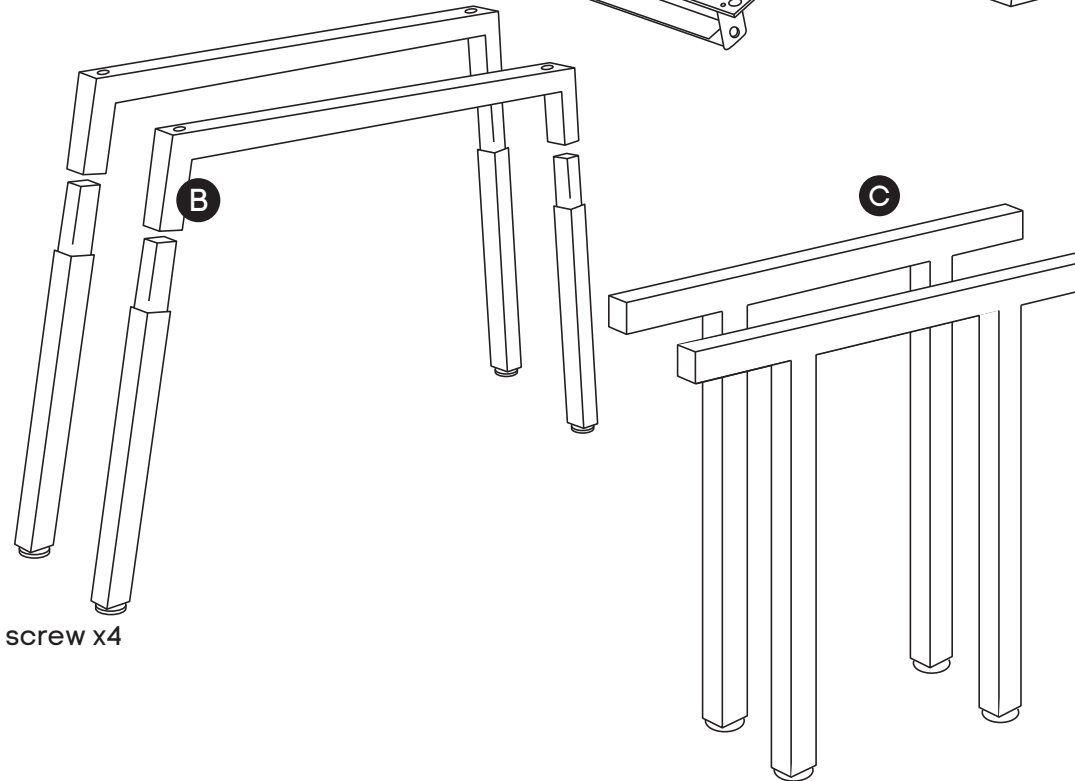

* Colour of the beam is always black, regardless desk frame colour.

ASSEMBLY INSTRUCTIONS

Quadro Wood A

3P Run workstation

www.jasonl.com.au

Need help!

Call us on
1300 527 665

jason.l
your office furniture mate



Sizes: 1200x700, 1400x700, 1600x700, 1800x700 mm

STEP 01

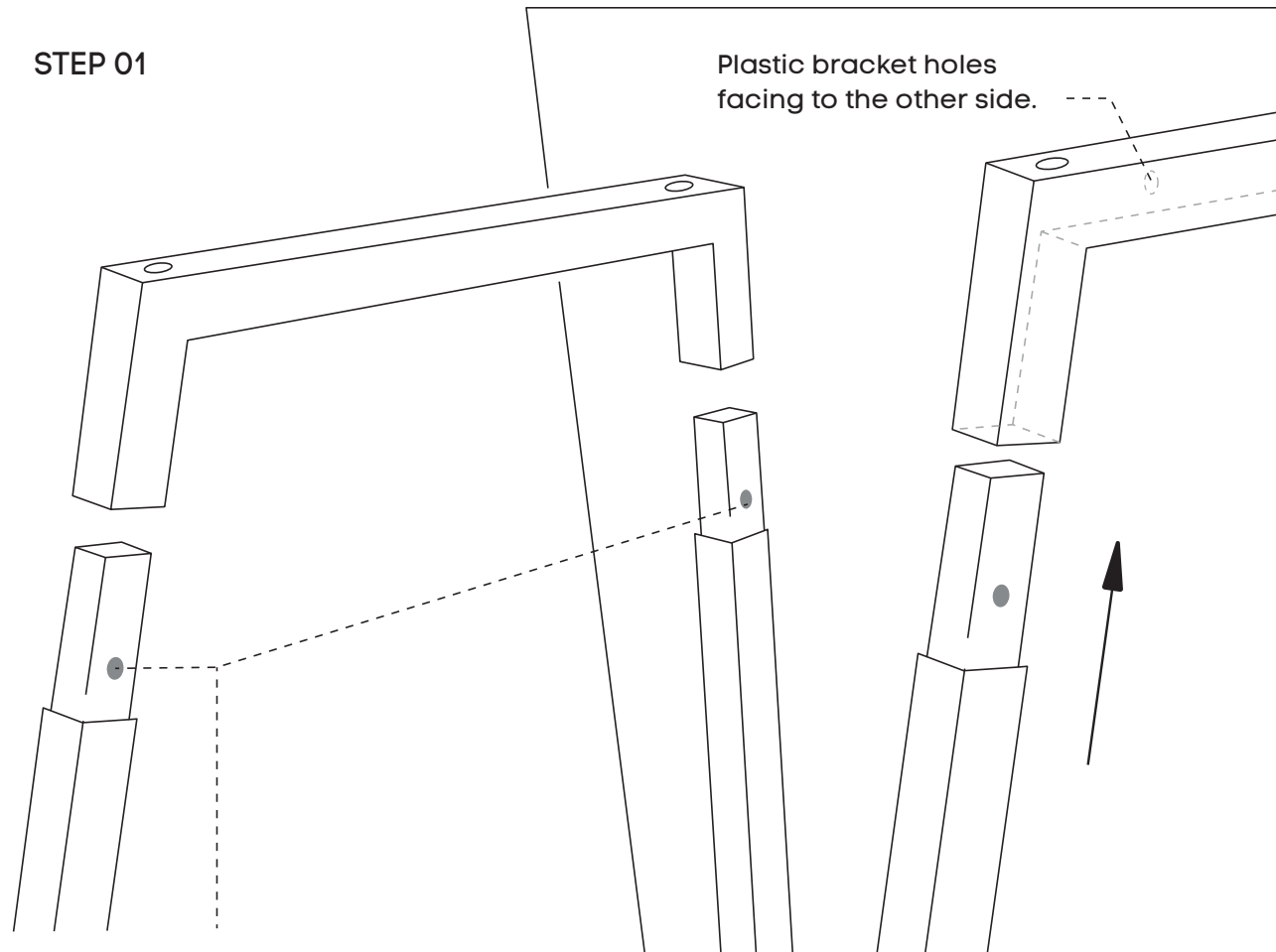

You will notice two colored stickers located on each leg.

Both legs must have the colour sticker facing away from where the plastic brackets are inserted.

STEP 02

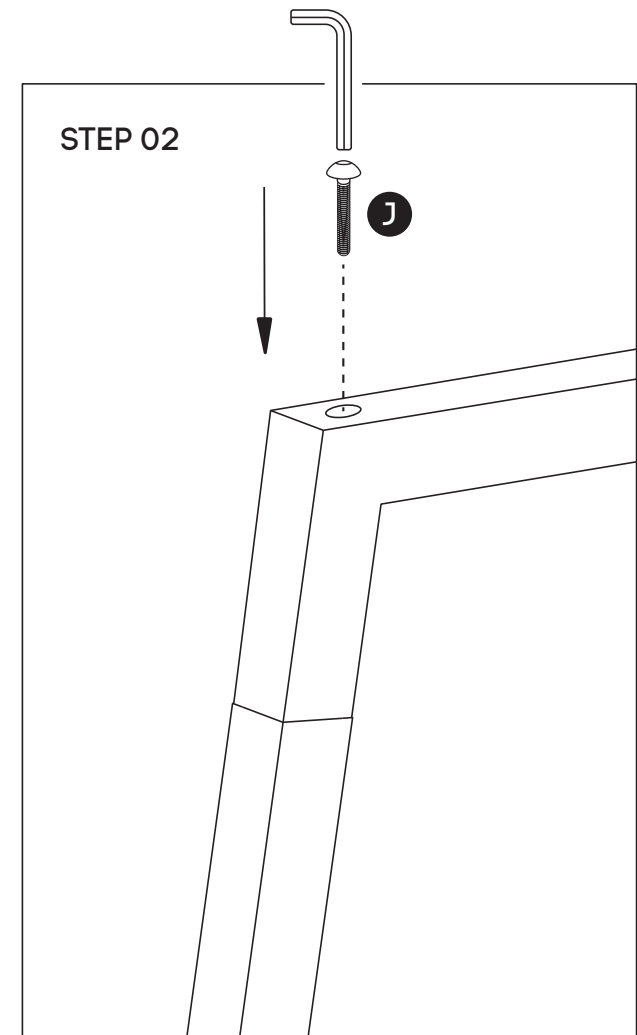

Insert the bottom of the legs as shown in the illustration. Using Allen Key provided, attach Mushroom Head Screw (J) - for all legs.

ASSEMBLY INSTRUCTIONS

Quadro Wood A

3P Run workstation

www.jasonl.com.au

Need help!

Call us on
1300 527 665

jason.l
your office furniture mate



Sizes: 1200x700, 1400x700, 1600x700, 1800x700 mm



Using Allen Key provided, attach 2 plastic brackets per leg **(E)** (as per picture above) using M6x20MM **(H)** Socket head screw. Do the same with Connector frame **(C)**.

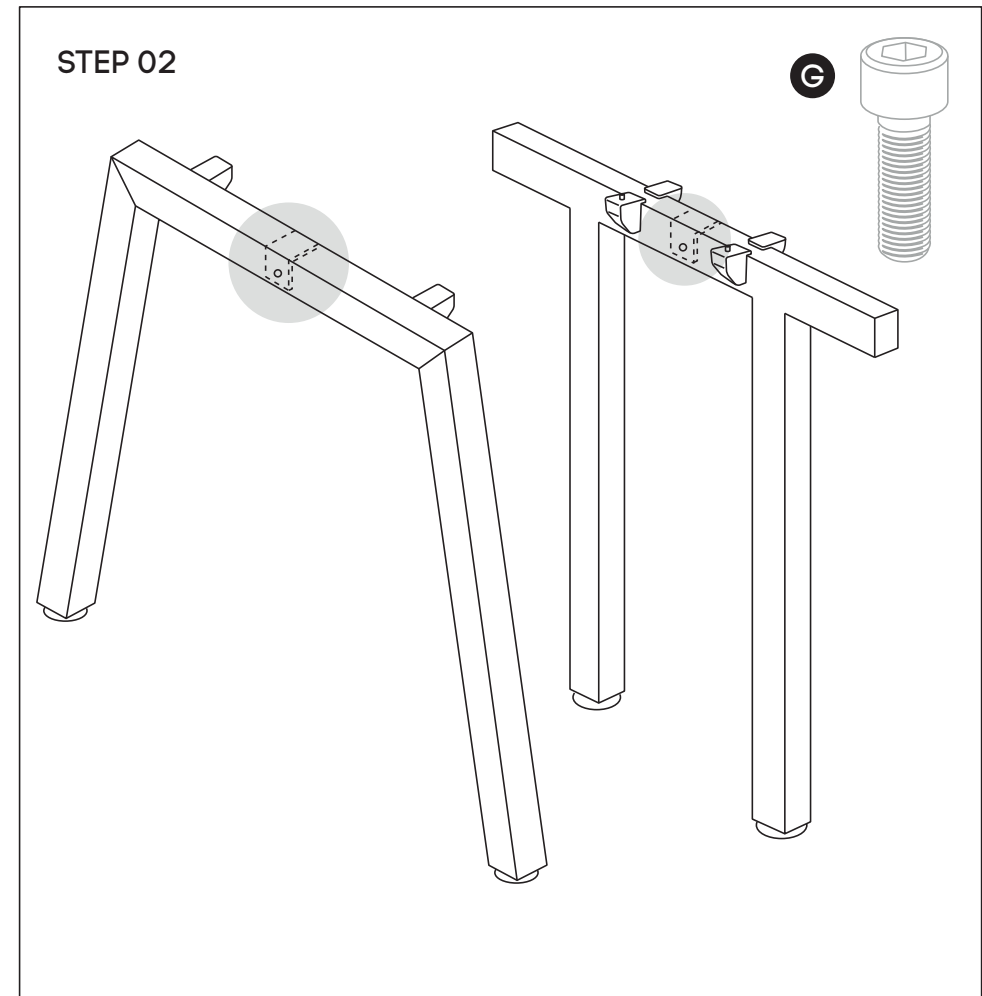

Using Allen Key provided, attach M8x20MM Socket head **(G)**-screw socket half way into leg for both legs **(B)** and into Connector frame **(C)**.

ASSEMBLY INSTRUCTIONS

Quadro Wood A

3P Run workstation

www.jasonl.com.au

Need help!
Call us on
1300 527 665

jason.l
your office furniture mate



Sizes: 1200x700, 1400x700, 1600x700, 1800x700 mm

STEP 03

Adjust extendable beam **(D)** to desired length using markers and secure beam at that length using screws provided

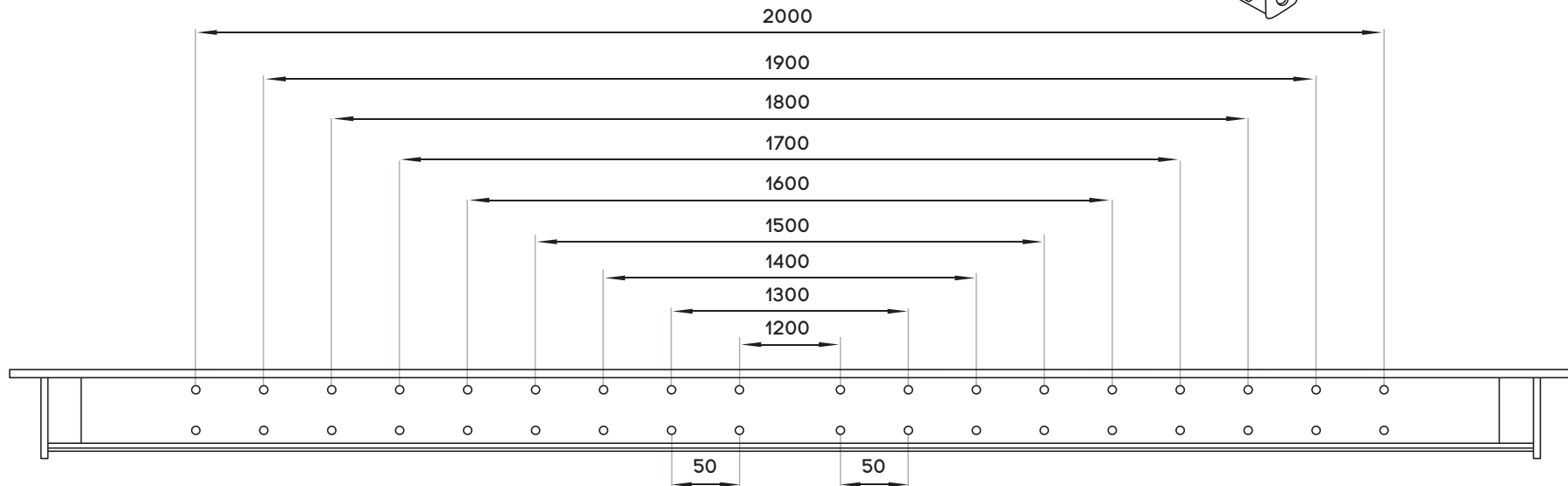
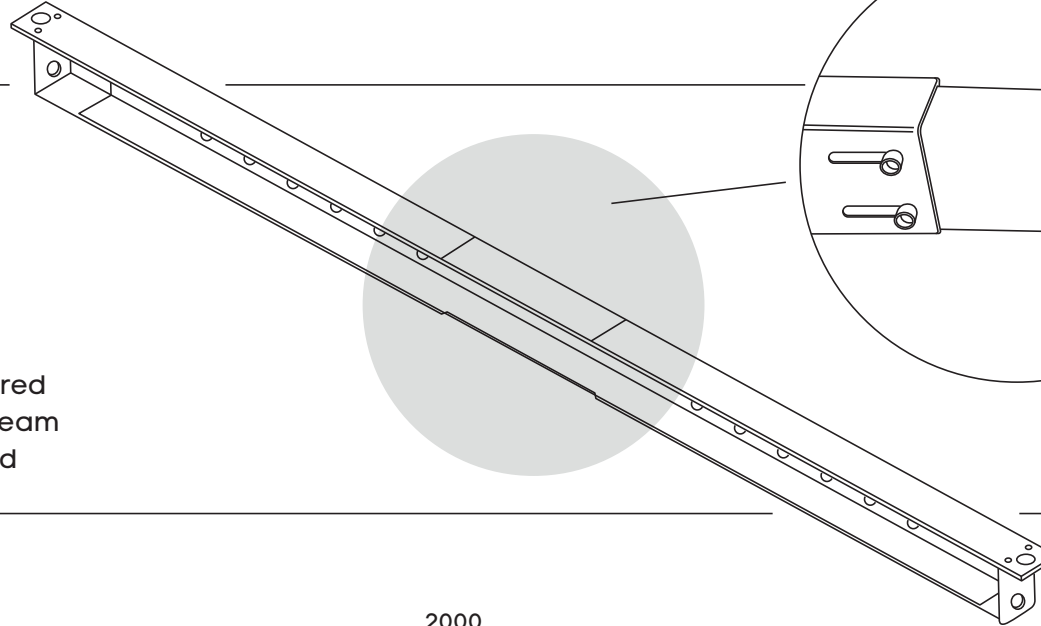

ASSEMBLY INSTRUCTIONS

Quadro Wood A

3P Run workstation

www.jasonl.com.au

Need help!

Call us on
1300 527 665

jason.l
your office furniture mate



Sizes: 1200x700, 1400x700, 1600x700, 1800x700 mm

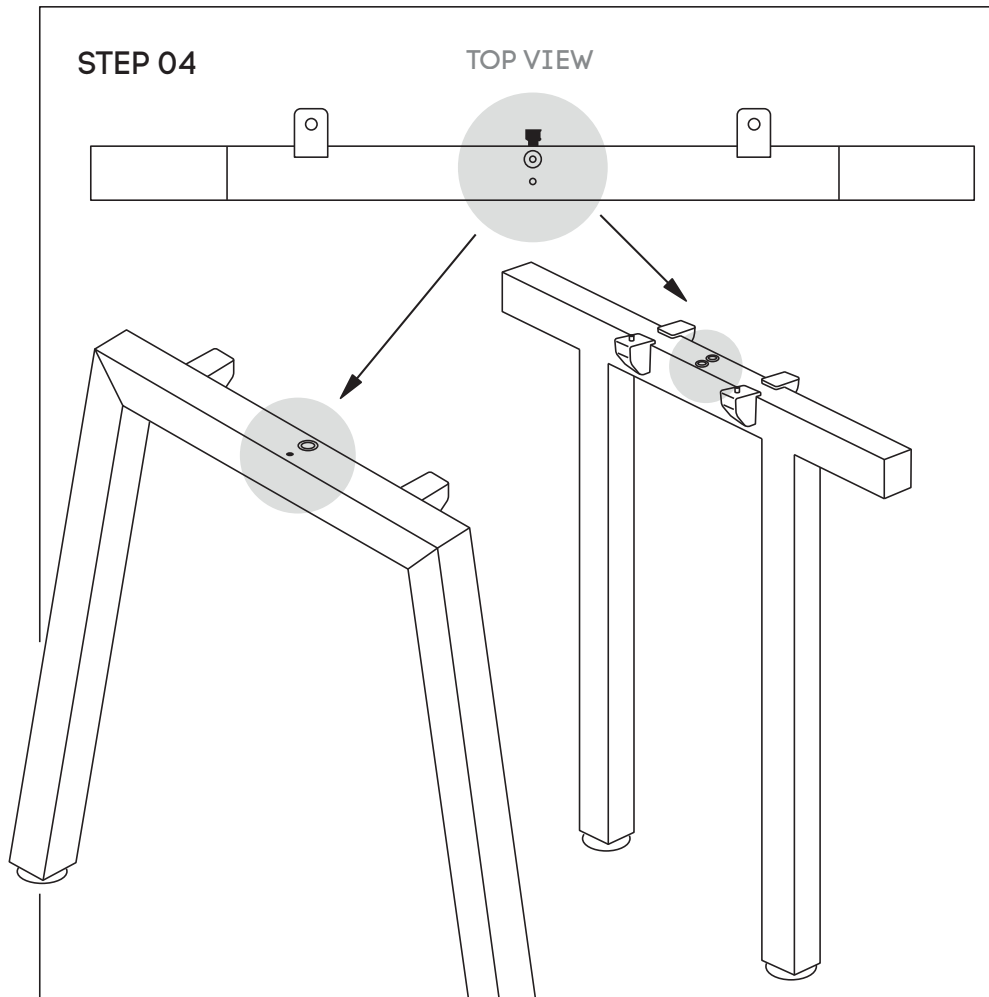

Attach beam **(D)** to legs **(B)** and Connector frame **(C)** using nut insert in legs. See point attached

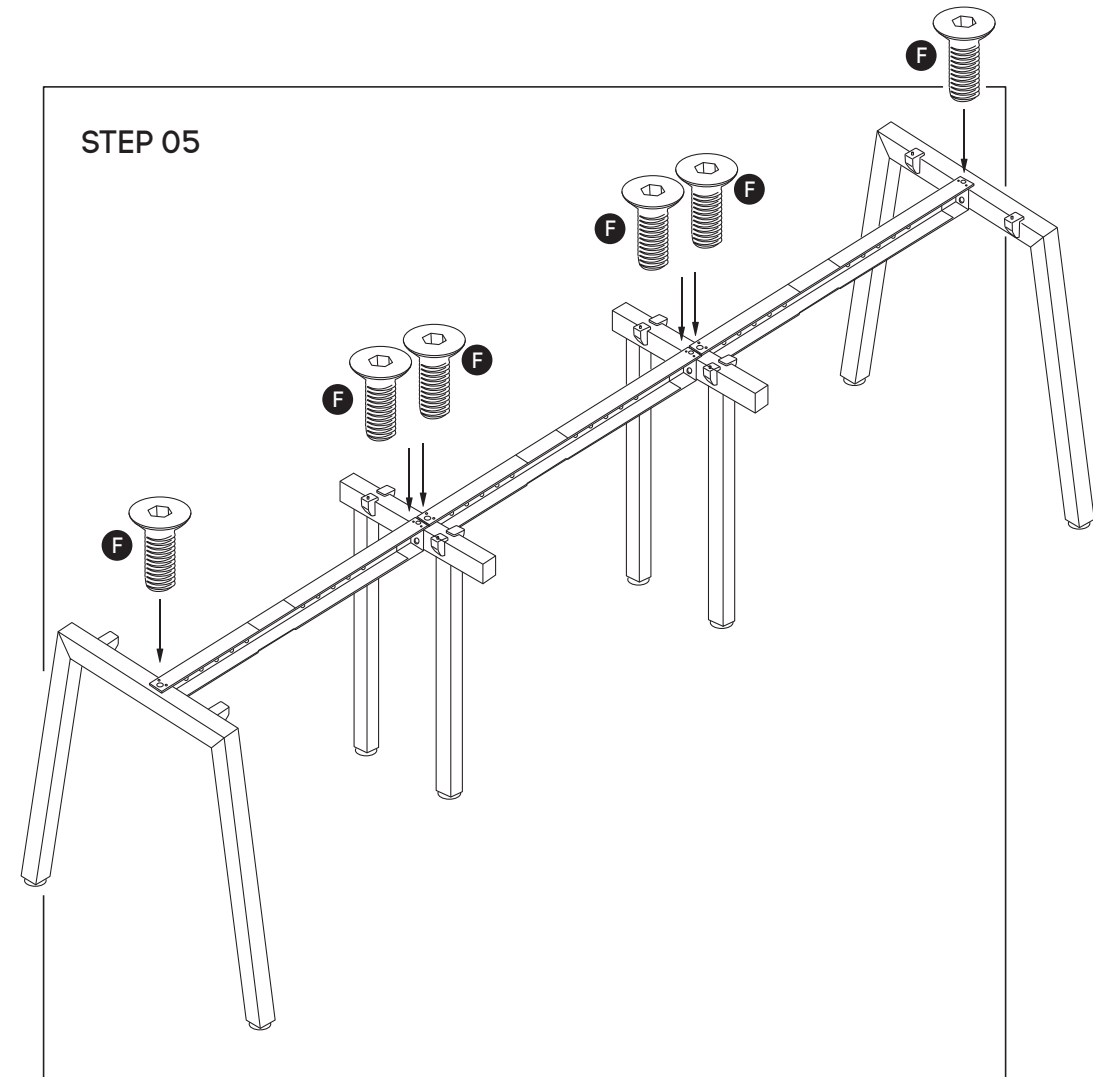

Frame looks like this. Using Allen Key, attach beam **(D)** with Socket **(F)**

ASSEMBLY INSTRUCTIONS

Quadro Wood A

3P Run workstation

Sizes: 1200x700, 1400x700, 1600x700, 1800x700 mm

www.jasonl.com.au

Need help!

Call us on
1300 527 665

jason.l
your office furniture mate



STEP 06

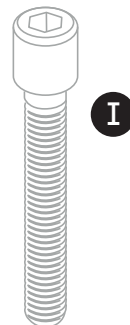
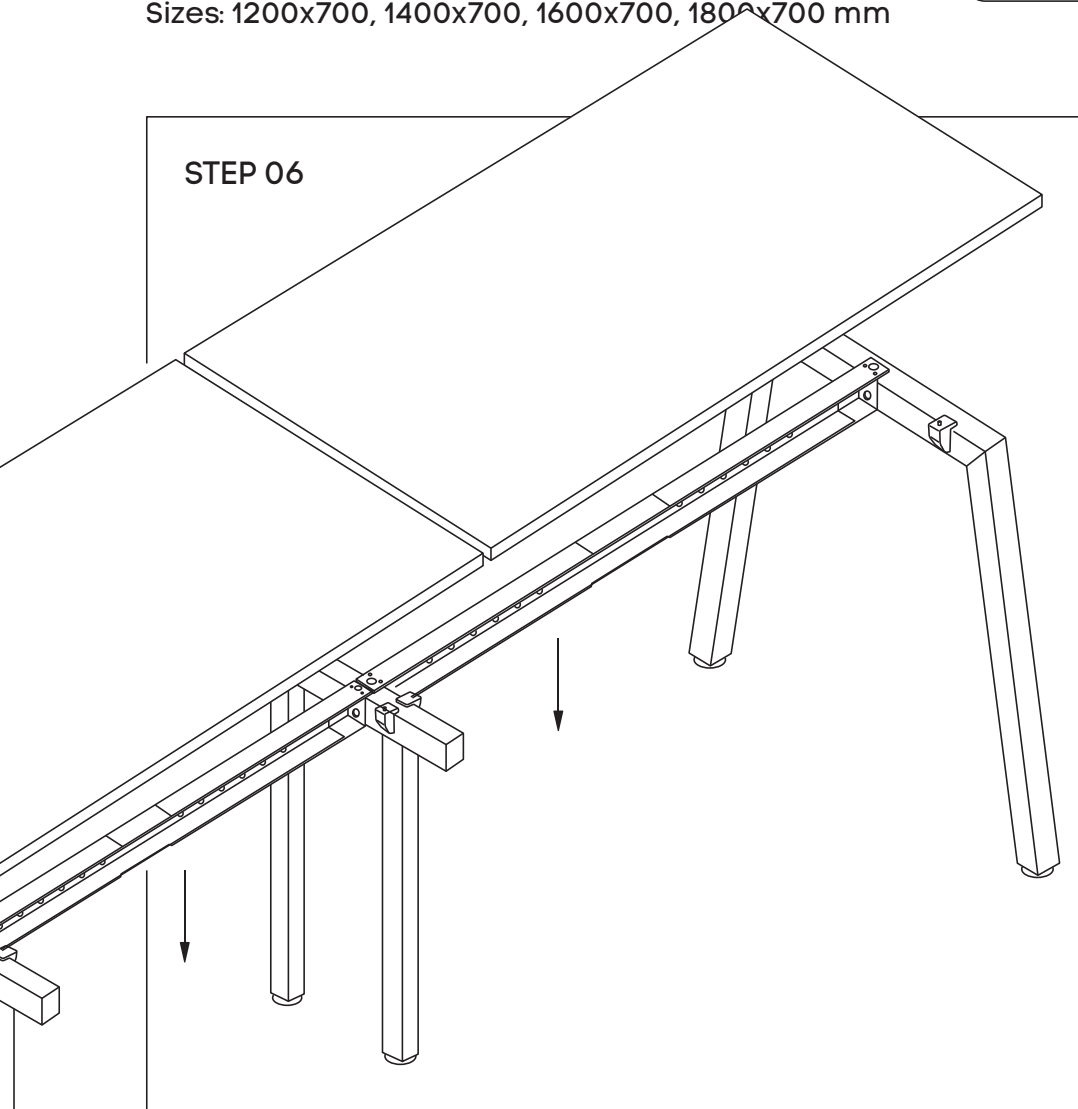
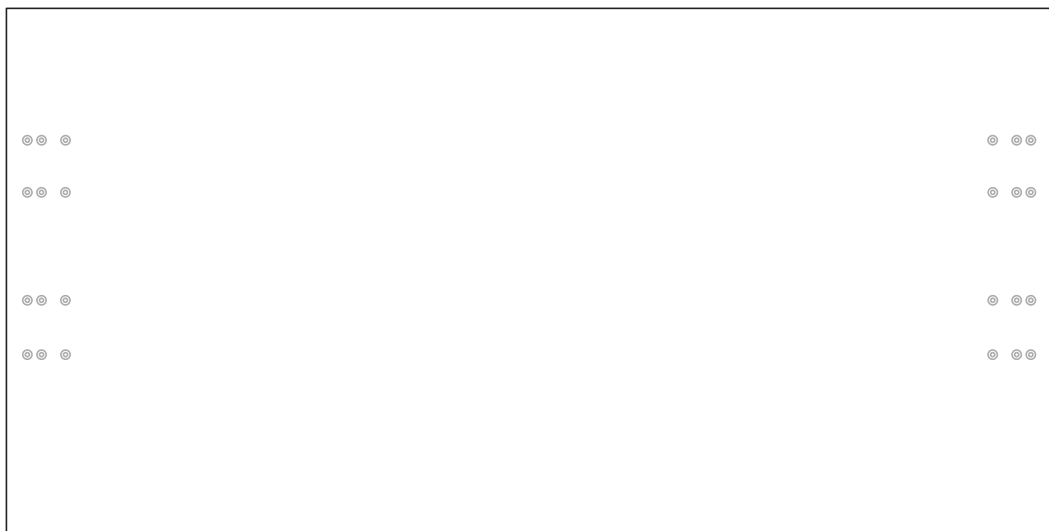

TABLE TOPS
BOTTOM VIEW



Place desktops on top of frame. Nut inserts in top will align with plastic joiner brackets using M6x30MM (I) sockets attach tops to frame.

ASSEMBLY INSTRUCTIONS

Quadro Wood A

3P Run workstation

Sizes: 1200x700, 1400x700, 1600x700, 1800x700 mm

www.jasonl.com.au

Need help!

Call us on
1300 527 665

jason.l
your office furniture mate



TABLE TOPS BOTTOM VIEW

The following nut inserts should be used for this specific desk / workstation

