

ASSEMBLY INSTRUCTIONS
Quadro A
2P Run workstation

Sizes: 1200, 1400, 1600, 1800 mm

www.jasonl.com.au

Need help!

Call us on
1300 527 665

jason.l
your office furniture mate

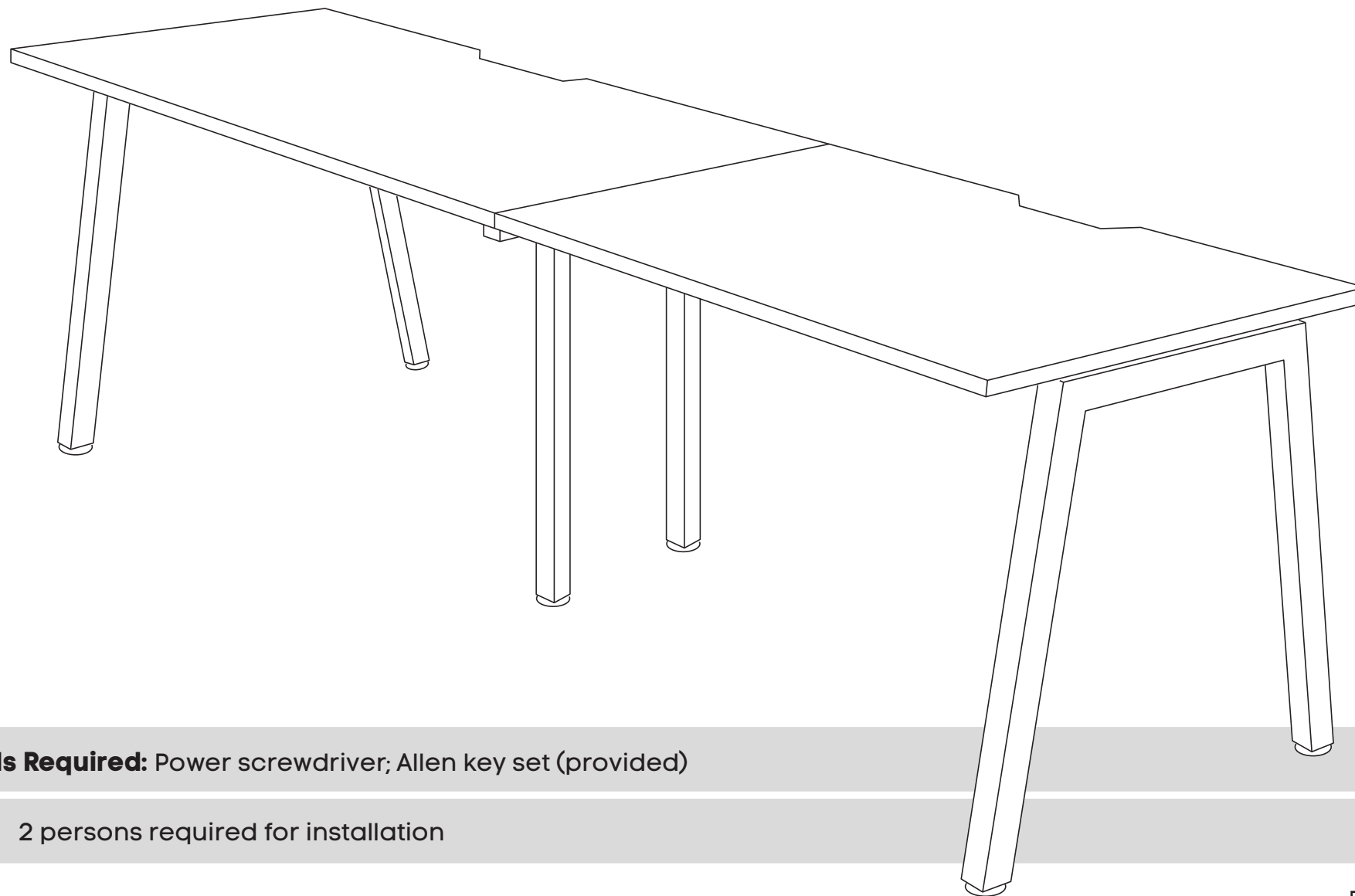

Tools Required: Power screwdriver; Allen key set (provided)

 2 persons required for installation

ASSEMBLY INSTRUCTIONS

Quadro A

2P Run workstation

Sizes: 1200, 1400, 1600, 1800 mm

www.jasonl.com.au

Need help!

Call us on
1300 527 665

jason.l
your office furniture mate

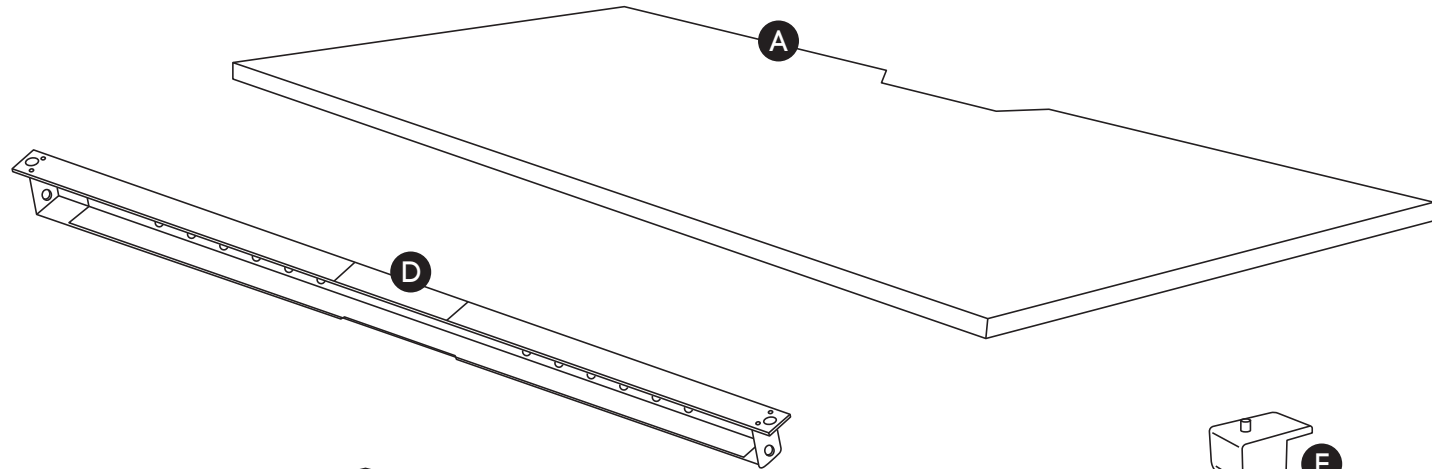

COMPONENTS

- A Table top x2
- B Leg Quadro A x2
- C Connector frame x1
- D Beam x2 *
- E Plastic bracket x8

SCREWS

- F M8x20MM CSK x4
- G M8x20MM Socket head x4
- H M6x20MM Socket head x8
- I M6x30MM Socket head x8

- J Allen key x2

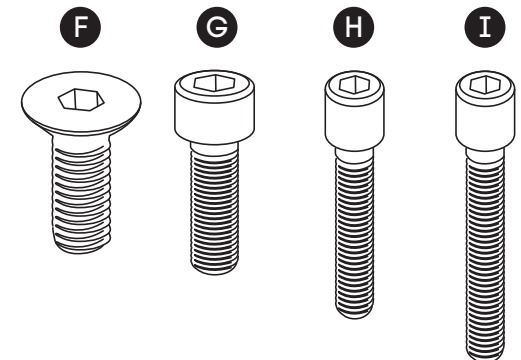
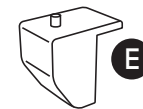
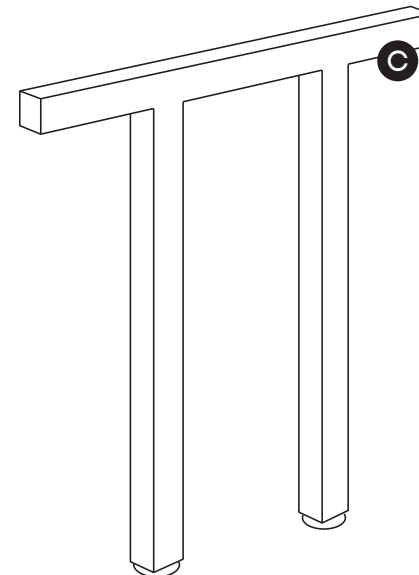
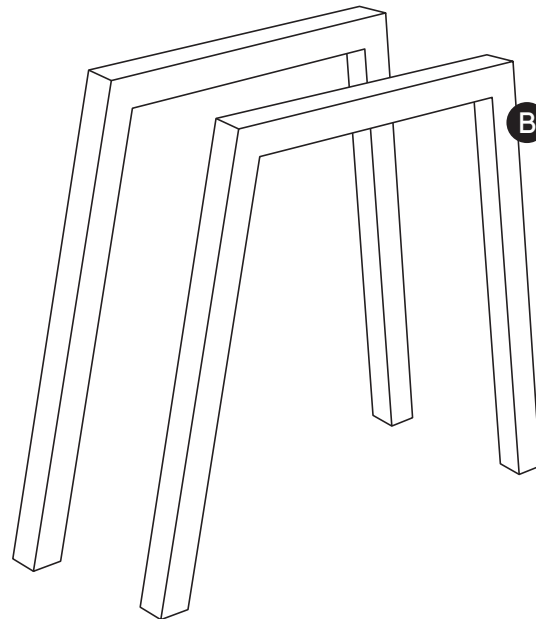

* Colour of the beam is always black, regardless desk frame colour.

ASSEMBLY INSTRUCTIONS

Quadro A

2P Run workstation

Sizes: 1200, 1400, 1600, 1800 mm

www.jasonl.com.au

Need help!

Call us on
1300 527 665

jason.l
your office furniture mate

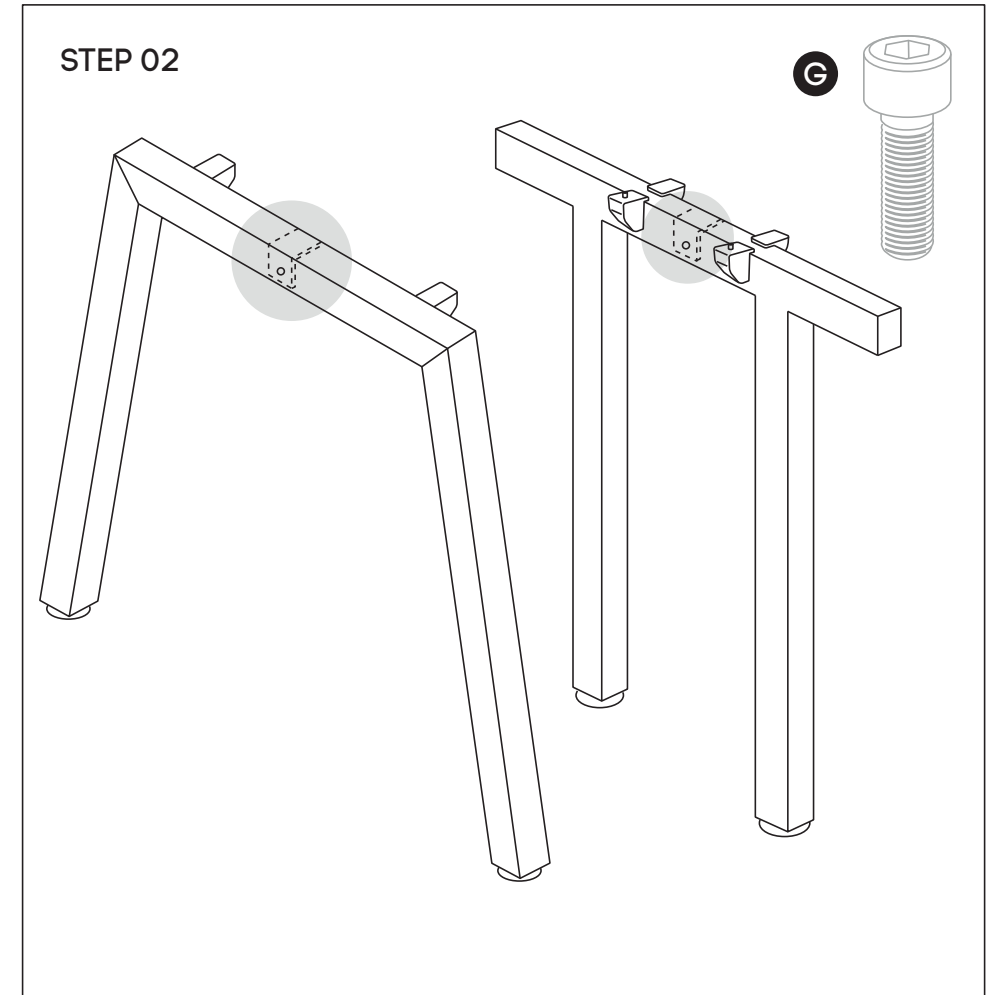
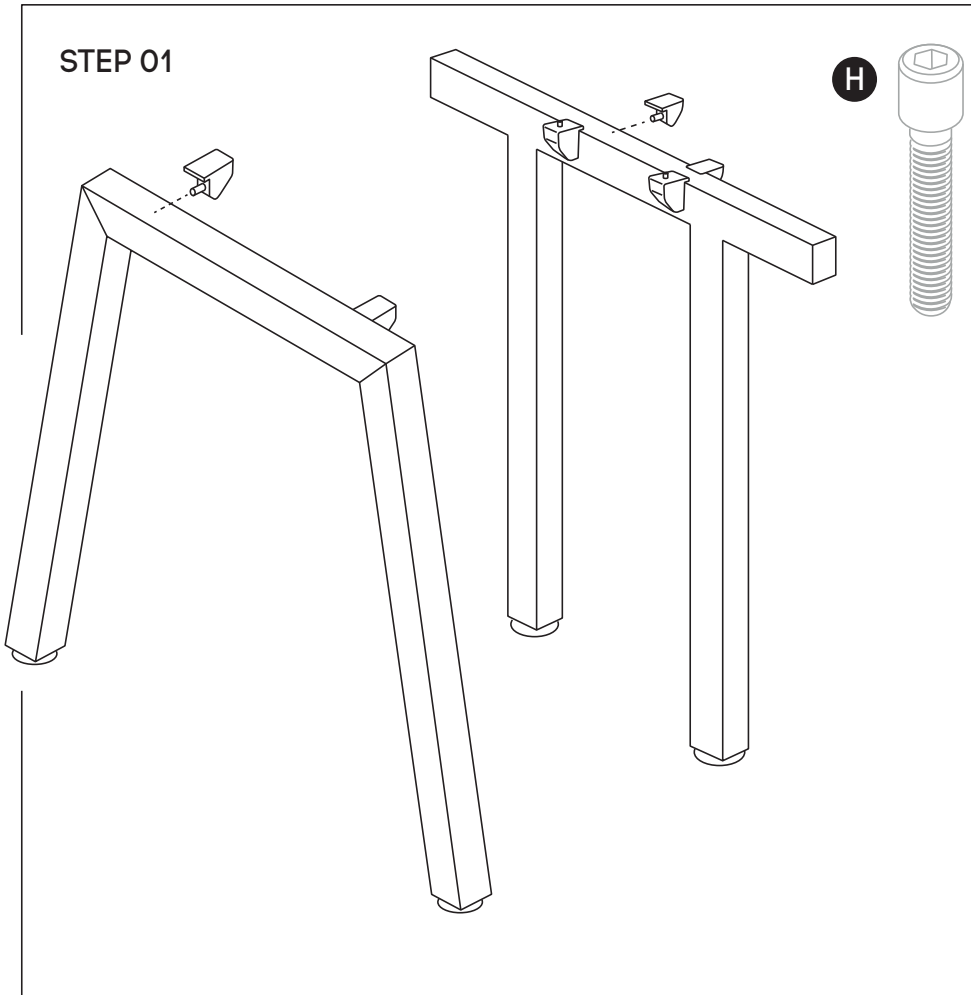

Using Allen Key provided, attach 2 plastic brackets per leg **(E)** (as per picture above) using M6x20MM **(H)** Socket head screw. Do the same with Connector frame **(C)**.

Using Allen Key provided, attach M8x20MM Socket head **(G)**-screw socket half way into leg for both legs **(B)** and into Connector frame **(C)**.

ASSEMBLY INSTRUCTIONS

Quadro A

2P Run workstation

Sizes: 1200, 1400, 1600, 1800 mm

www.jasonl.com.au

Need help!

Call us on
1300 527 665

jason.l
your office furniture mate



STEP 03

Adjust extendable beam **(D)** to desired length using markers and secure beam at that length using screws provided

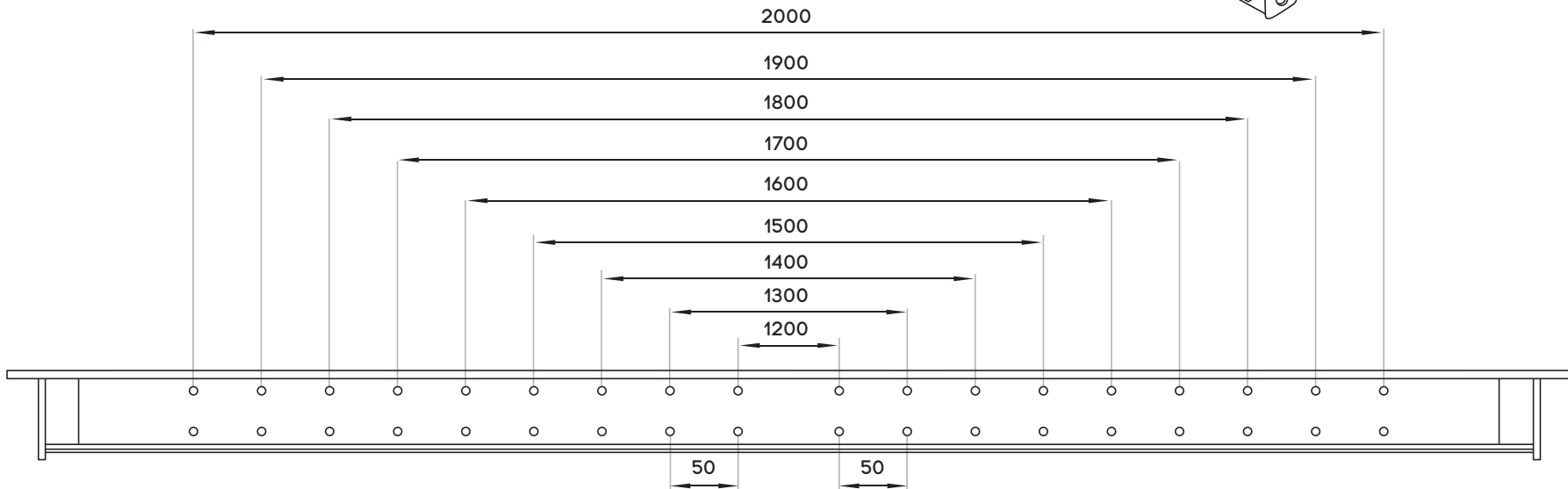
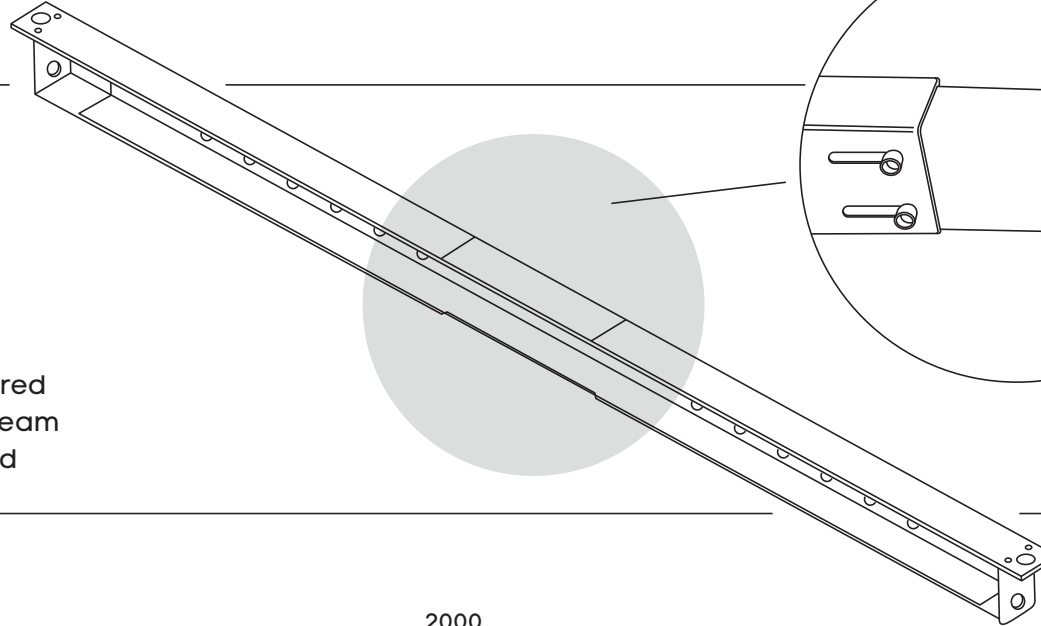

ASSEMBLY INSTRUCTIONS

Quadro A

2P Run workstation

Sizes: 1200, 1400, 1600, 1800 mm

www.jasonl.com.au

Need help!

Call us on
1300 527 665

jason.l
your office furniture mate

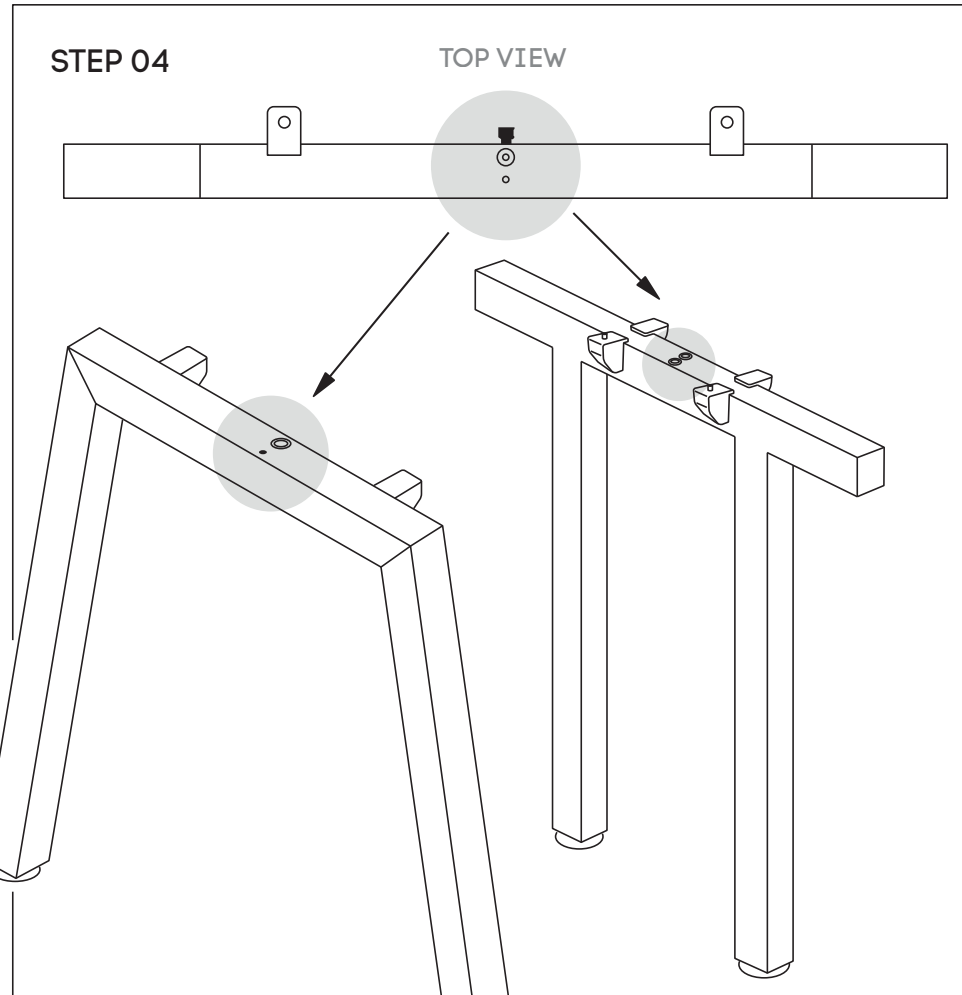

Attach beam **(D)** to legs **(B)** and Connector frame **(C)** using nut insert in legs. See point attached

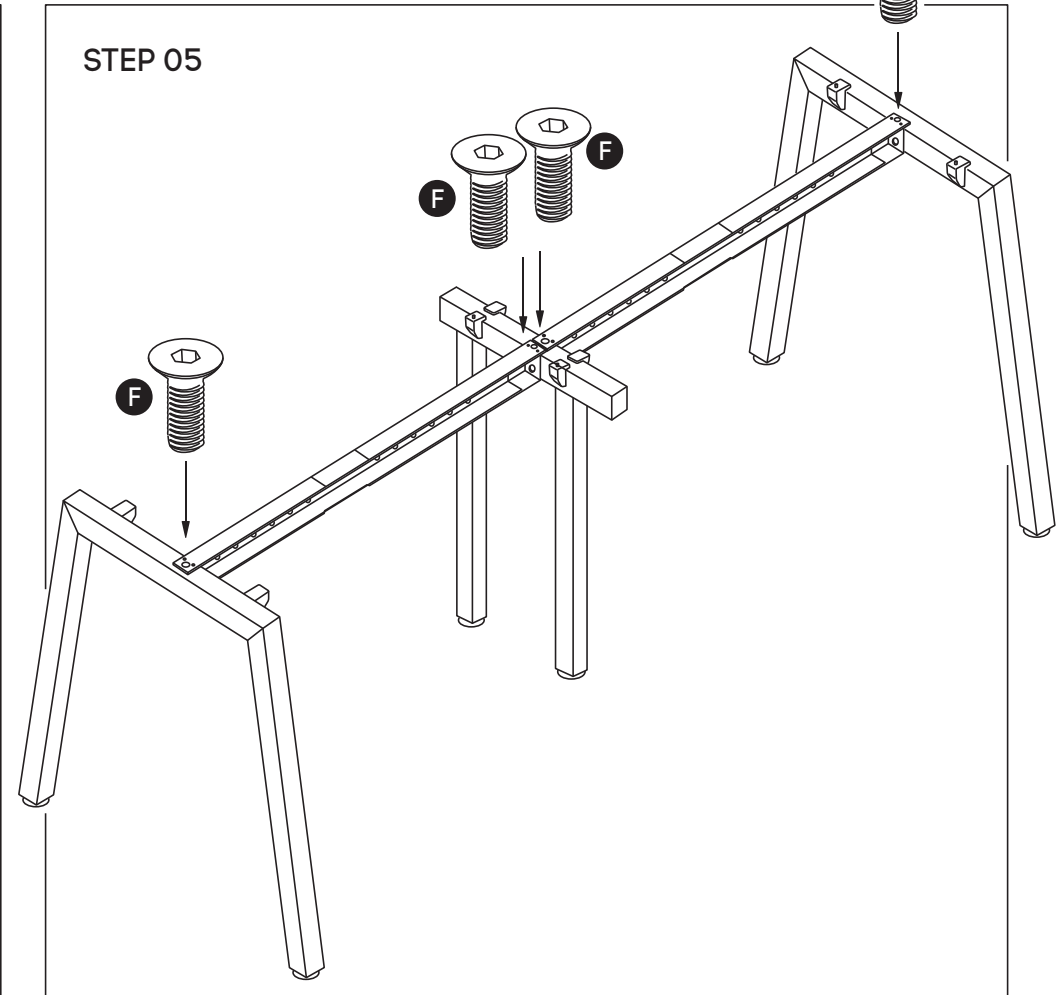

Frame looks like this. Using Allen Key, attach beam **(D)** with Socket **(F)**

ASSEMBLY INSTRUCTIONS

Quadro A

2P Run workstation

Sizes: 1200, 1400, 1600, 1800 mm

www.jasonl.com.au

Need help!

Call us on
1300 527 665

jason.l
your office furniture mate

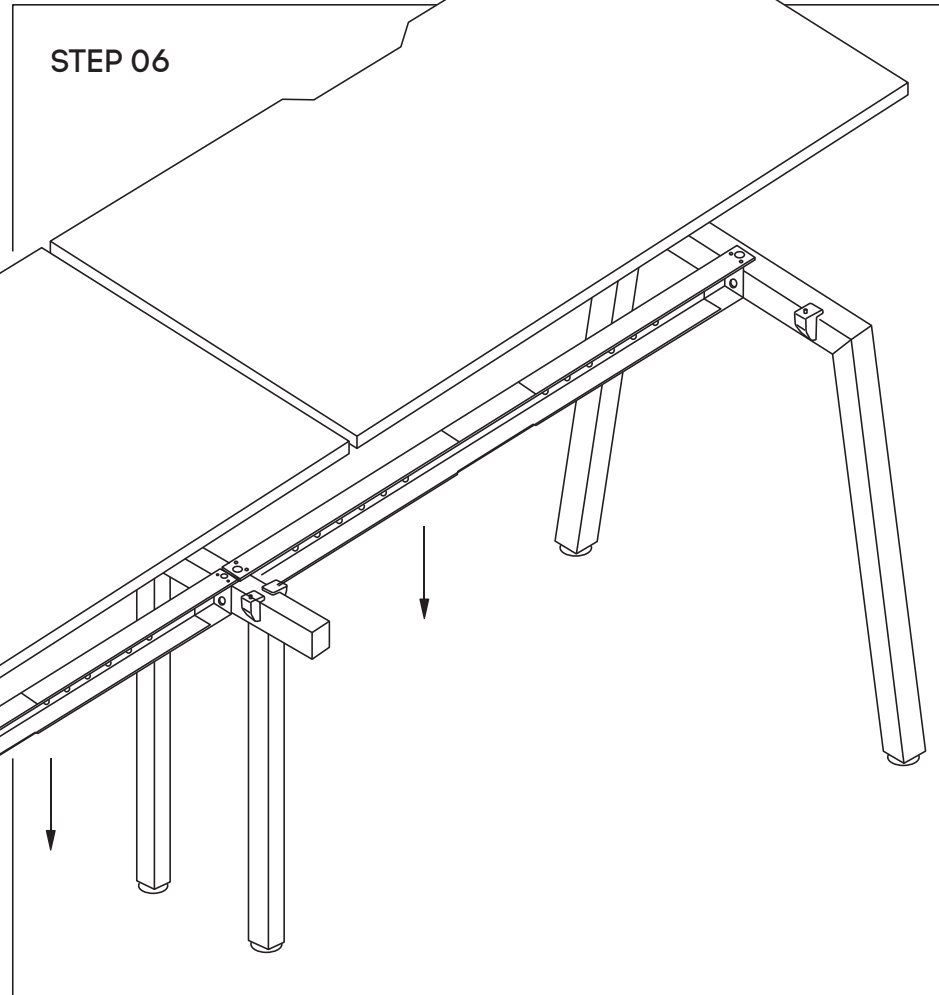

Place desktops ontop of frame - with cutout at the back of the desk.
Nut inserts in top will align with plastic joiner brackets using M6x30MM
(I) sockets attached tops to frame.

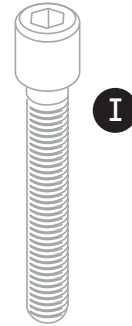
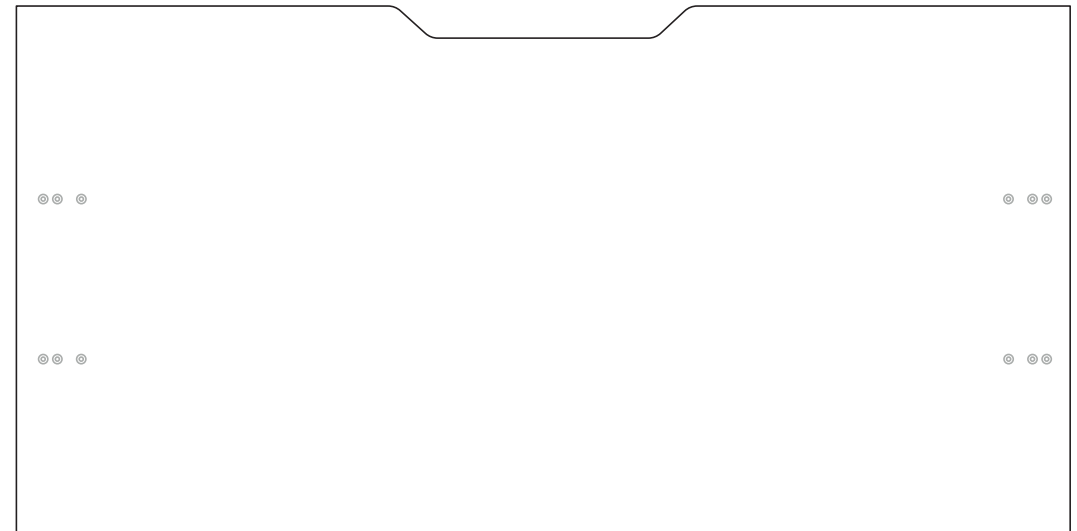

TABLE TOP
BOTTOM VIEW



ASSEMBLY INSTRUCTIONS
Quadro A
2P Run workstation

Sizes: 1200, 1400, 1600, 1800 mm

www.jasonl.com.au

Need help!

Call us on
1300 527 665

jason.l
your office furniture mate



TABLE TOPS
BOTTOM VIEW

The following nut inserts should be used for this specific desk / workstation

