

**ASSEMBLY INSTRUCTIONS**  
**Quadro Wood A**  
**4P workstation**

Sizes: 1200, 1400, 1600, 1800 mm

[www.jasonl.com.au](http://www.jasonl.com.au)

**Need help!**

Call us on  
**1300 527 665**

**jason.l**  
your office furniture mate

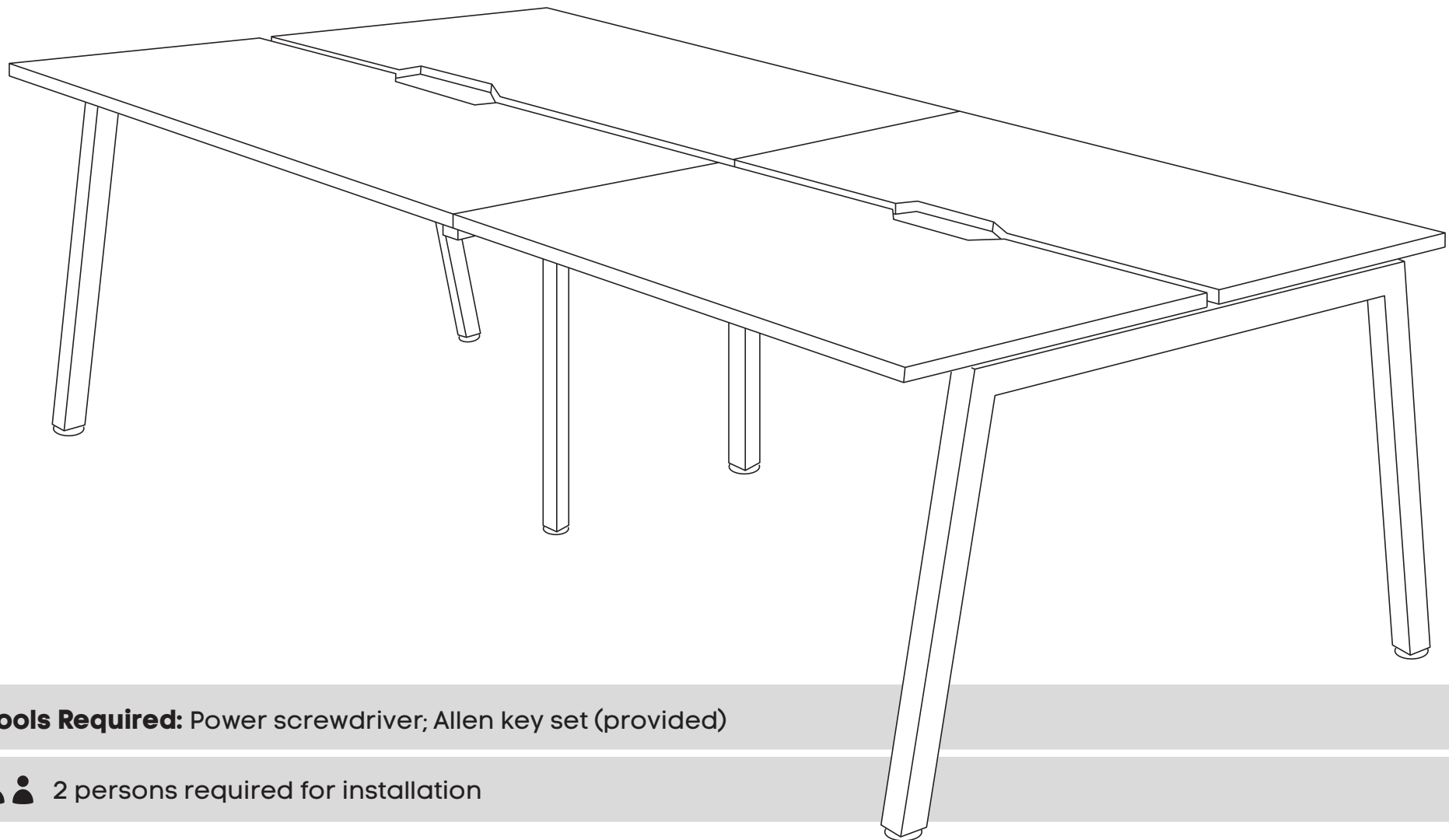

**Tools Required:** Power screwdriver; Allen key set (provided)

 2 persons required for installation

# ASSEMBLY INSTRUCTIONS

## Quadro Wood A 4P workstation

Sizes: 1200, 1400, 1600, 1800 mm

[www.jasonl.com.au](http://www.jasonl.com.au)

**Need help!**

Call us on  
**1300 527 665**

**jason.l**  
your office furniture mate

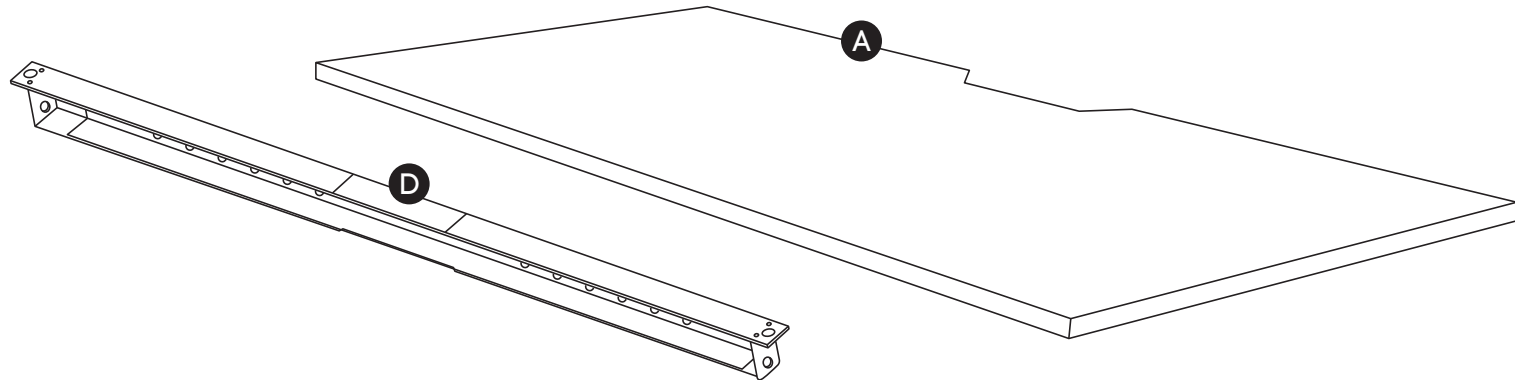

### COMPONENTS

- A Table top x4
- B Leg Quadro A x2
- C Connector frame x1
- D Beam x4 \*
- E Plastic bracket x16

### SCREWS

- F M8x20MM CSK x8
- G M8x20MM Socket head x8
- H M6x20MM Socket head x16
- I M6x30MM Socket head x16
- J M6x30mm Mushroom head screw x4

- K Allen key x2

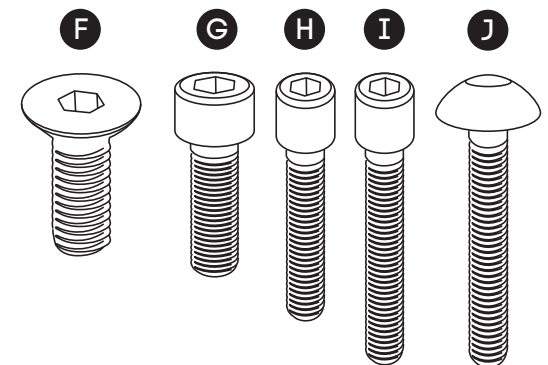
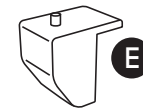
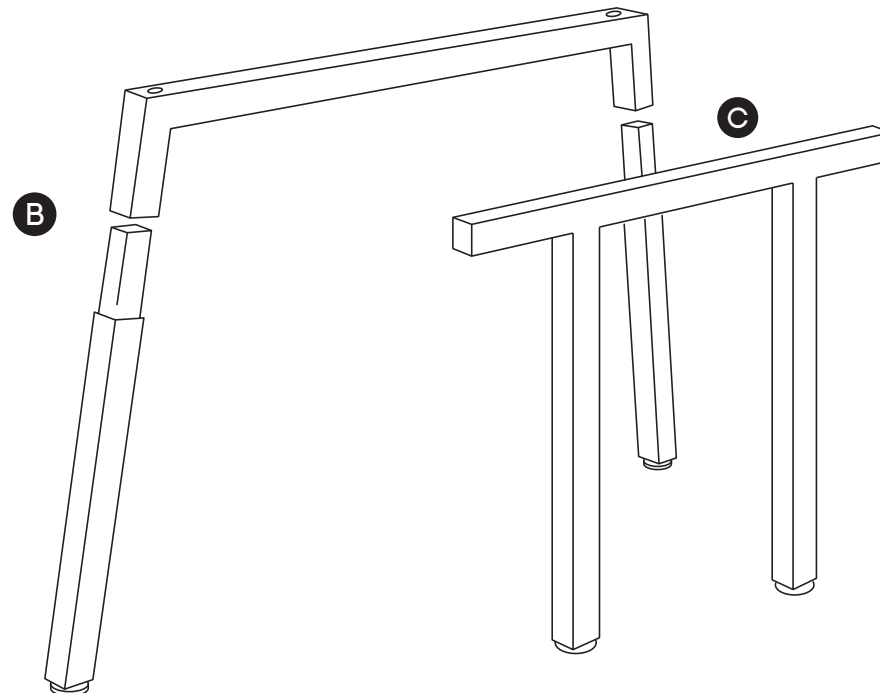

\* Colour of the beam is always black, regardless desk frame colour.

# ASSEMBLY INSTRUCTIONS

## Quadro Wood A 4P workstation

Sizes: 1200, 1400, 1600, 1800 mm

[www.jasonl.com.au](http://www.jasonl.com.au)

**Need help!**

Call us on  
**1300 527 665**

**jason.l**  
your office furniture mate



### STEP 01

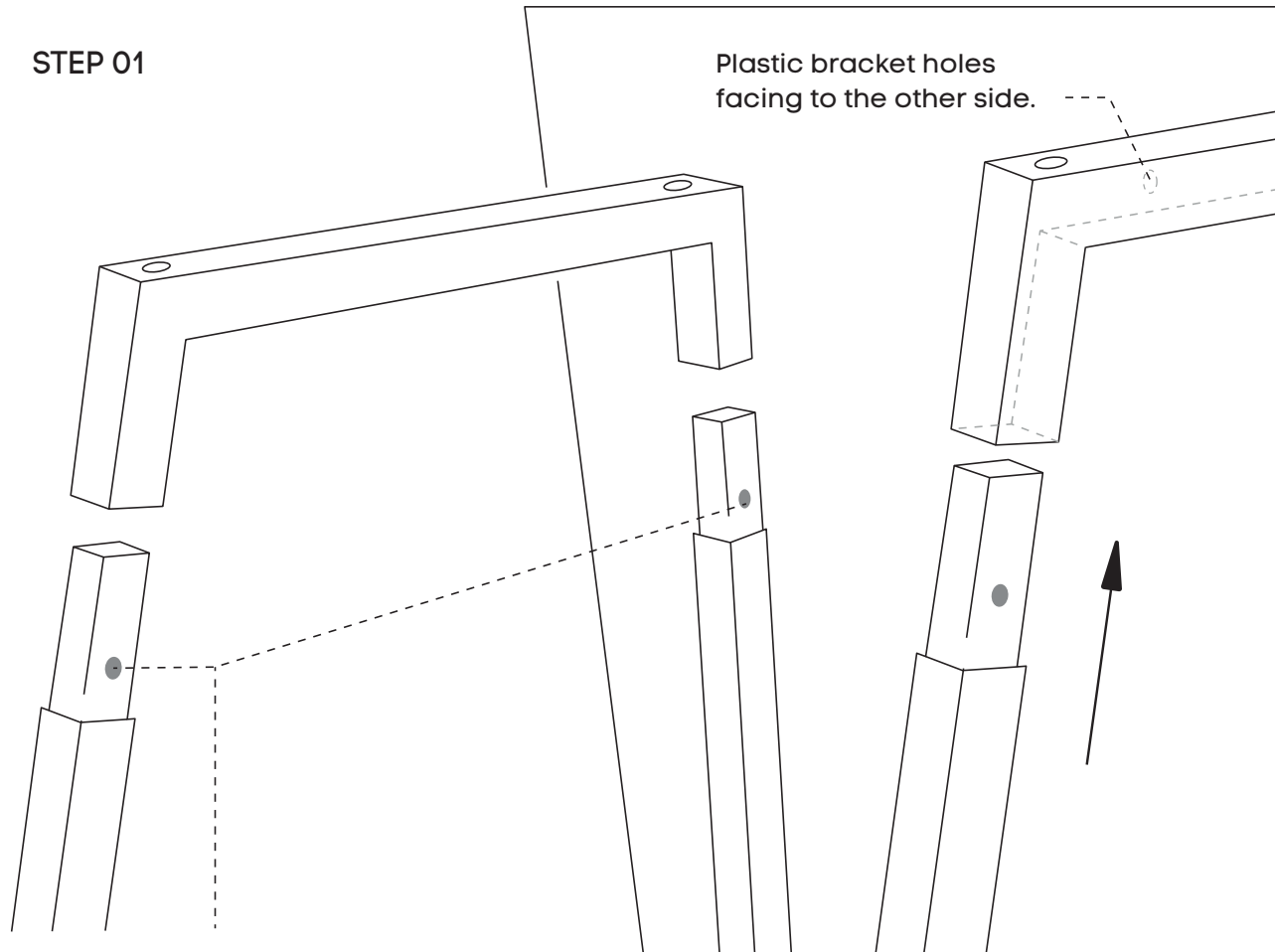

You will notice two colored stickers located on each leg.

Both legs must have the colour sticker facing away from where the plastic brackets are inserted.

### STEP 02

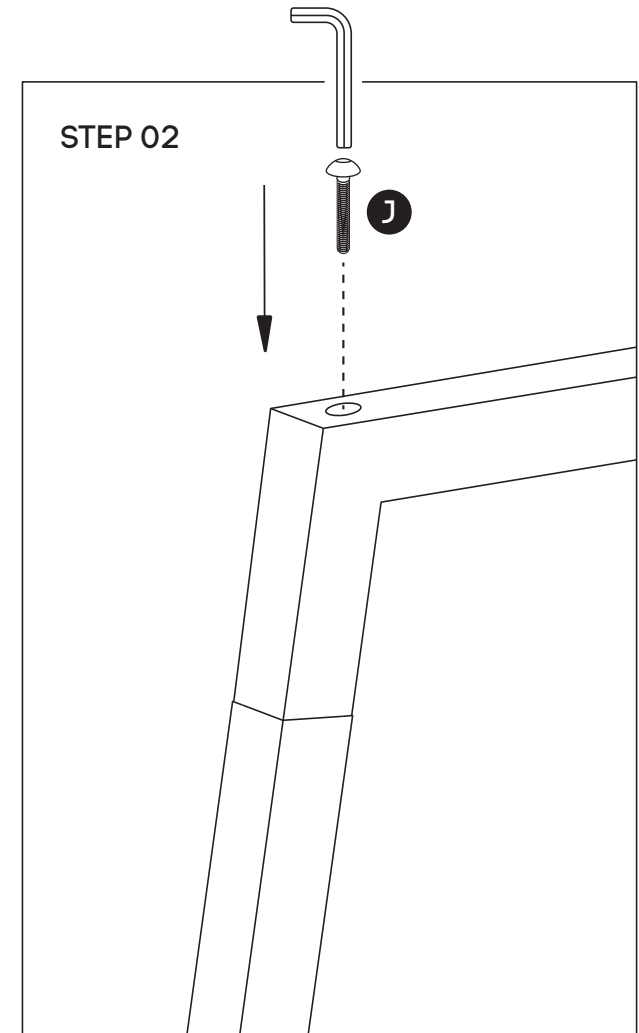

Insert the bottom of the legs as shown in the illustration. Using Allen Key provided, attach Mushroom Head Screw (J) - for all legs.

# ASSEMBLY INSTRUCTIONS

## Quadro Wood A 4P workstation

Sizes: 1200, 1400, 1600, 1800 mm

[www.jasonl.com.au](http://www.jasonl.com.au)

**Need help!**

Call us on  
**1300 527 665**

**jason.l**  
your office furniture mate

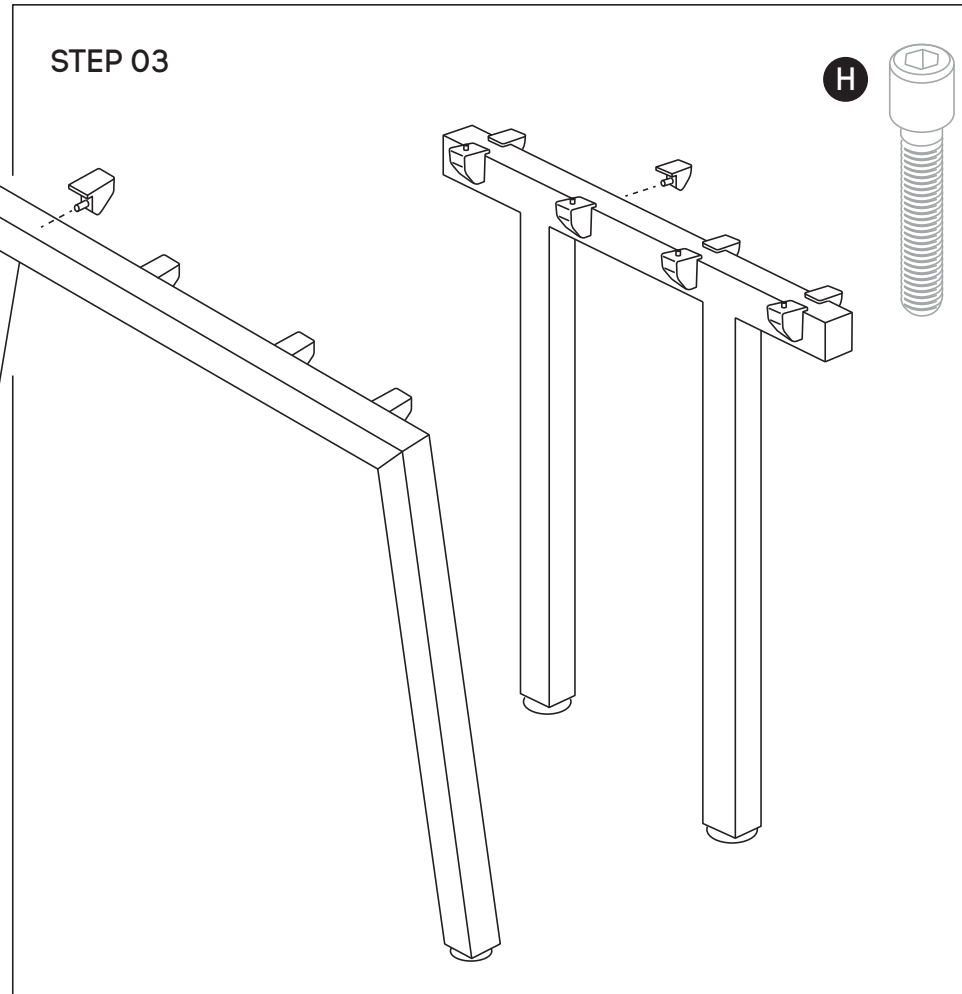

Using Allen Key provided, attach 4 plastic brackets per leg **(E)** (as per picture above) using M6x20MM **(H)** Socket head screw. Do the same with Connector frame **(C)**.



Using Allen Key provided, attach M8x20MM Socket head **(G)**-screw socket half way into leg for both legs **(B)** and into Connector frame **(C)**.

# ASSEMBLY INSTRUCTIONS

## Quadro Wood A 4P workstation

Sizes: 1200, 1400, 1600, 1800 mm

[www.jasonl.com.au](http://www.jasonl.com.au)

**Need help!**

Call us on  
**1300 527 665**

**jason.l**  
your office furniture mate



### STEP 05

Adjust extendable beam **(D)** to desired length using markers and secure beam at that length using screws provided

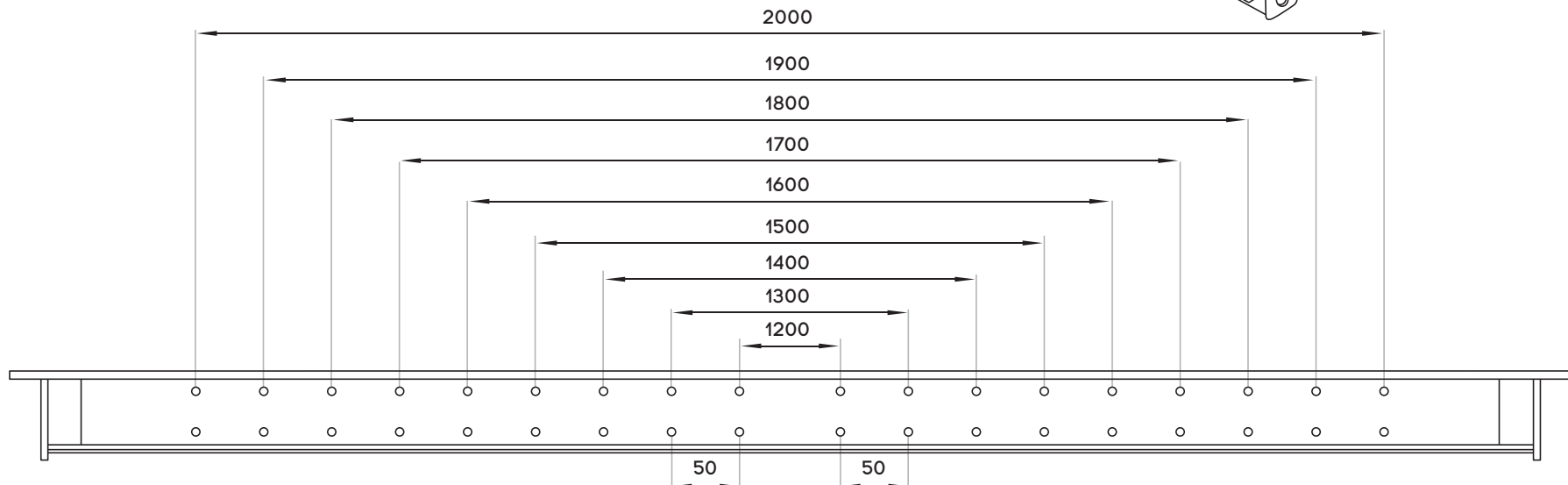
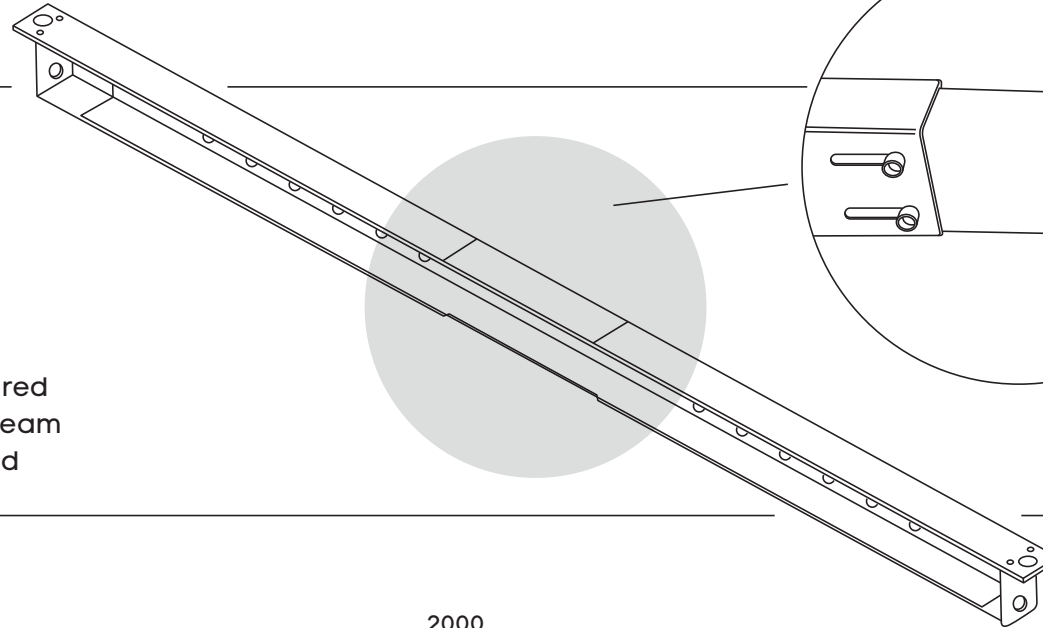

# ASSEMBLY INSTRUCTIONS

## Quadro Wood A 4P workstation

Sizes: 1200, 1400, 1600, 1800 mm

[www.jasonl.com.au](http://www.jasonl.com.au)

**Need help!**

Call us on  
**1300 527 665**

**jason.l**  
your office furniture mate

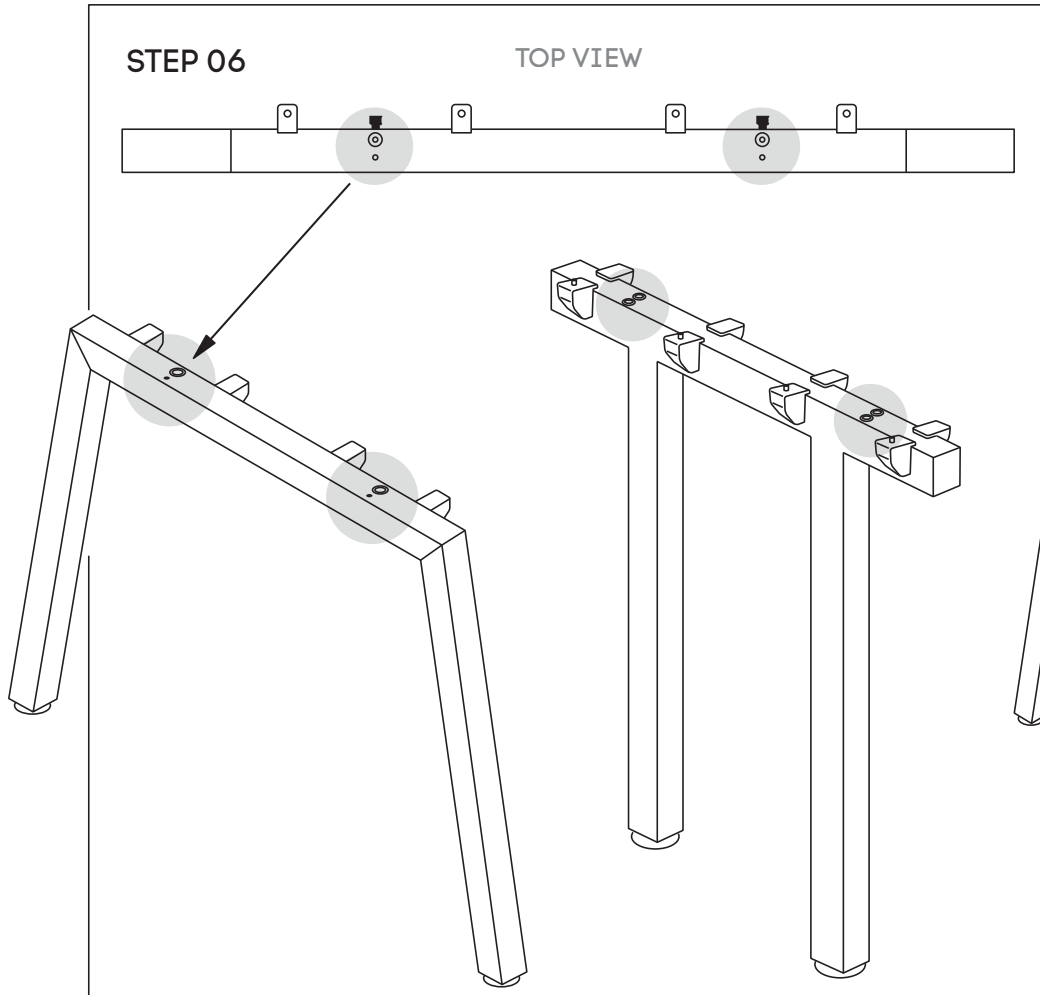

Attach beam **(D)** to legs **(B)** and Connector frame **(C)** using nut insert in legs. See point attached

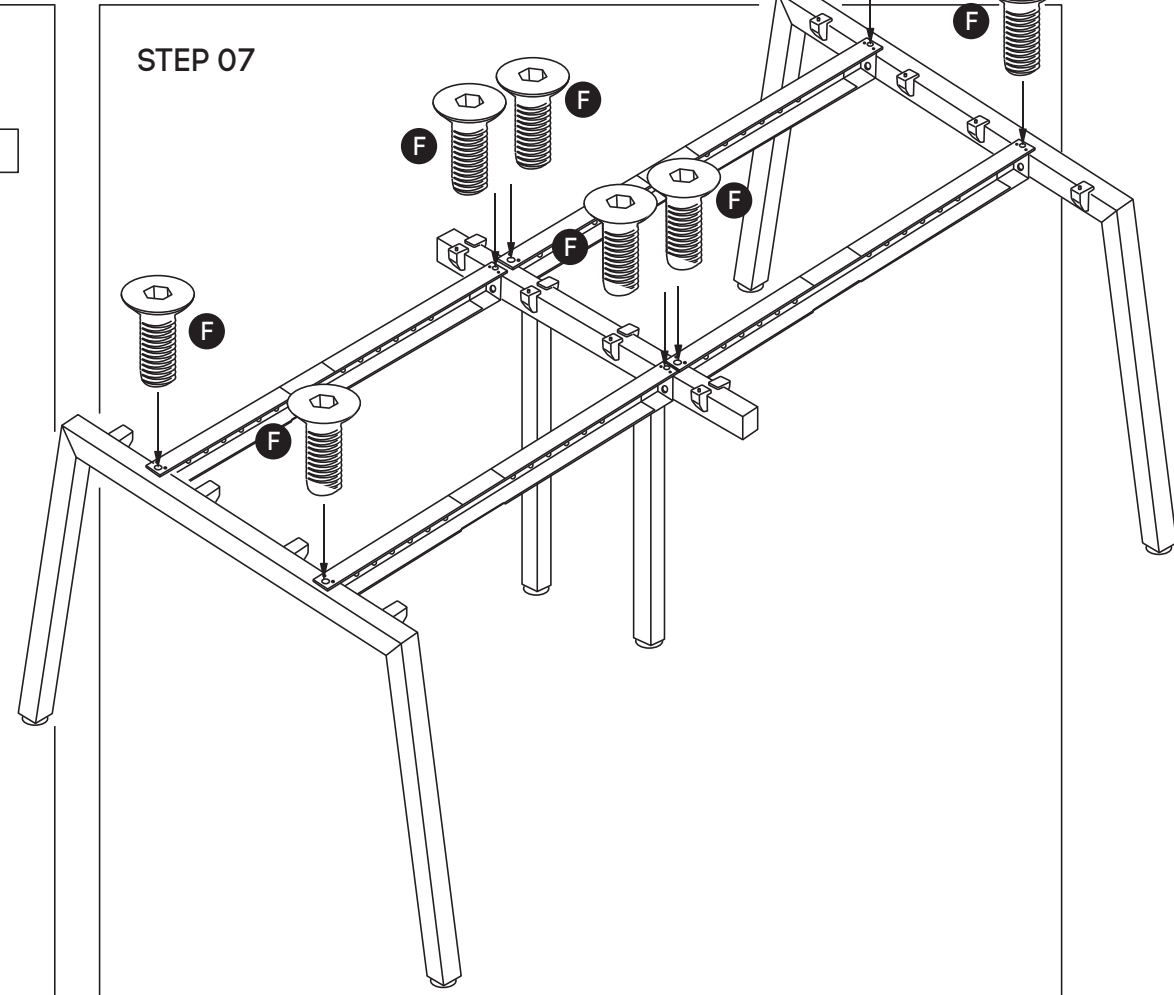

Frame looks like this. Using Allen Key, attach beam **(D)** with Socket **(F)**

# ASSEMBLY INSTRUCTIONS

## Quadro Wood A 4P workstation

Sizes: 1200, 1400, 1600, 1800 mm

[www.jasonl.com.au](http://www.jasonl.com.au)

**Need help!**

Call us on  
**1300 527 665**

**jason.l**  
your office furniture mate

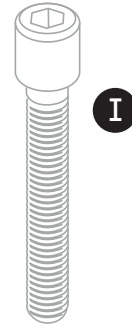
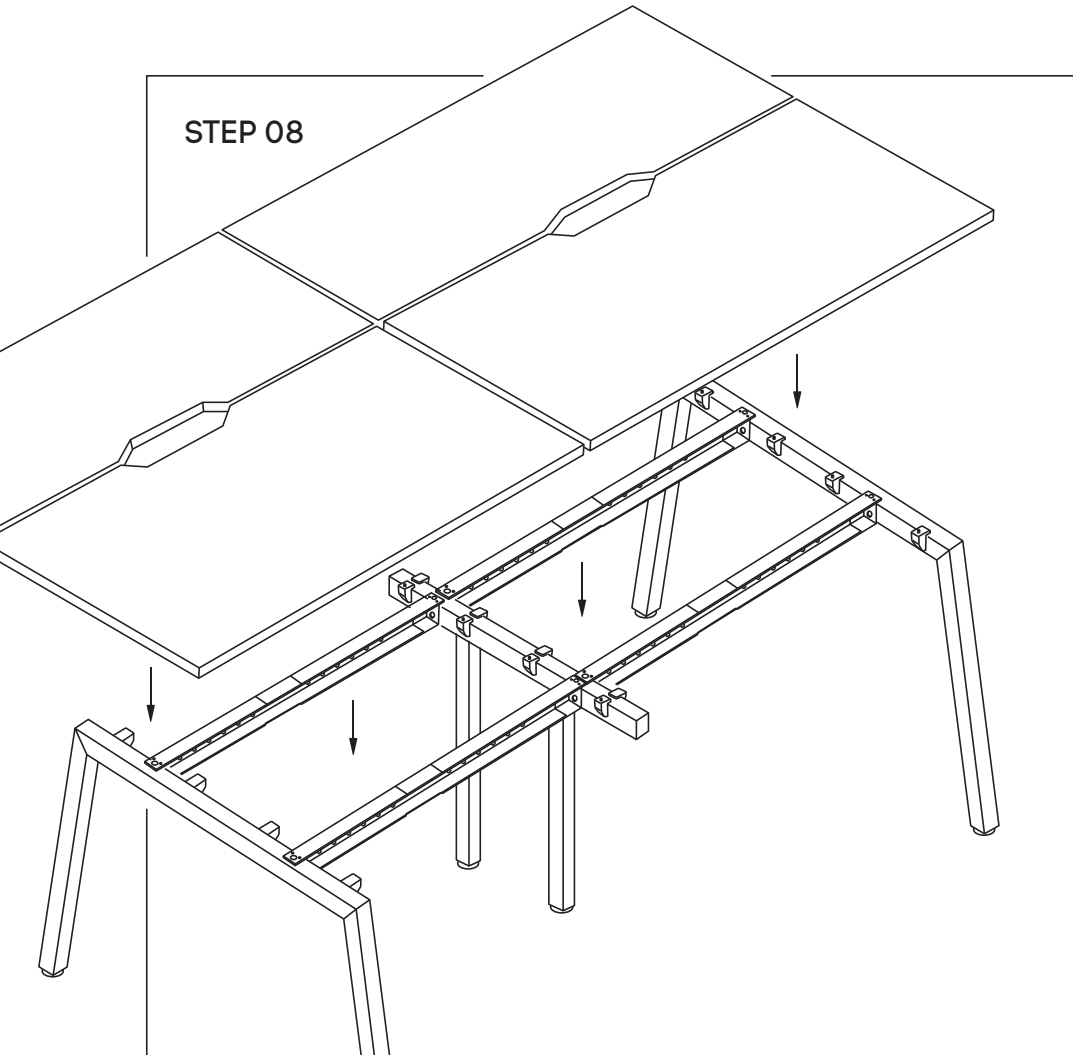
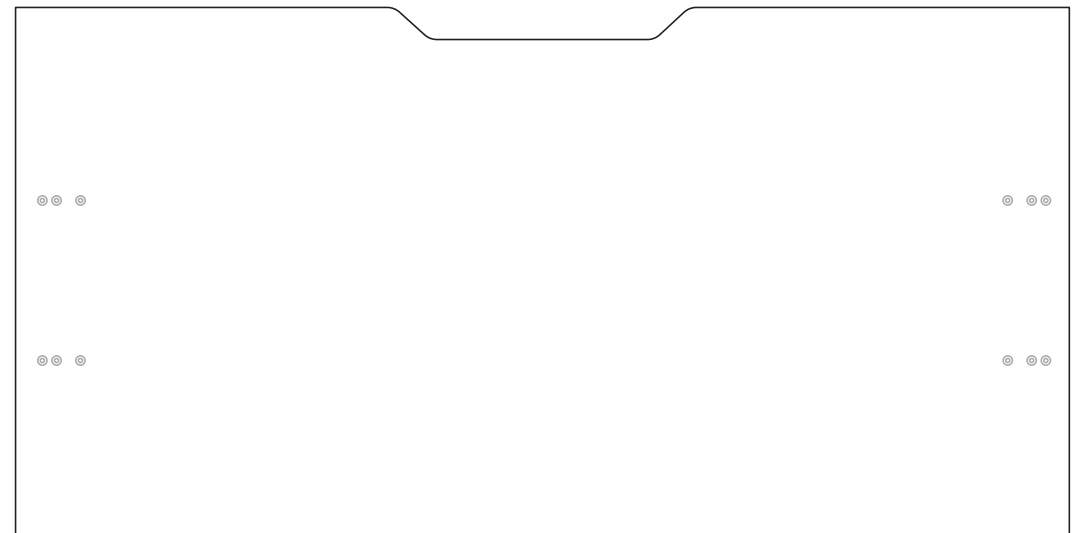

TABLE TOP  
BOTTOM VIEW



Place desktops ontop of frame - with cutout at the back of the desk. Nut inserts in top will align with plastic joiner brackets using M6x30MM (1) sockets attached tops to frame.

# ASSEMBLY INSTRUCTIONS

## Quadro Wood A 4P workstation

Sizes: 1200, 1400, 1600, 1800 mm

[www.jasonl.com.au](http://www.jasonl.com.au)

**Need help!**

Call us on  
**1300 527 665**

**jason.l**  
your office furniture mate



### TABLE TOPS BOTTOM VIEW

The following nut inserts should be used for this specific desk / workstation

