

ASSEMBLY INSTRUCTIONS

Quadro Wood A leg Counter table with intermediate legs

www.jasonl.com.au

Need help!

Call us on
1300 527 665

jason.l
your office furniture mate



Sizes:

2400L x 700D mm

2800L x 700D mm

3200L x 700D mm

3600L x 700D mm

2400L x 1200D mm

3000L x 1200D mm

3600L x 1200D mm

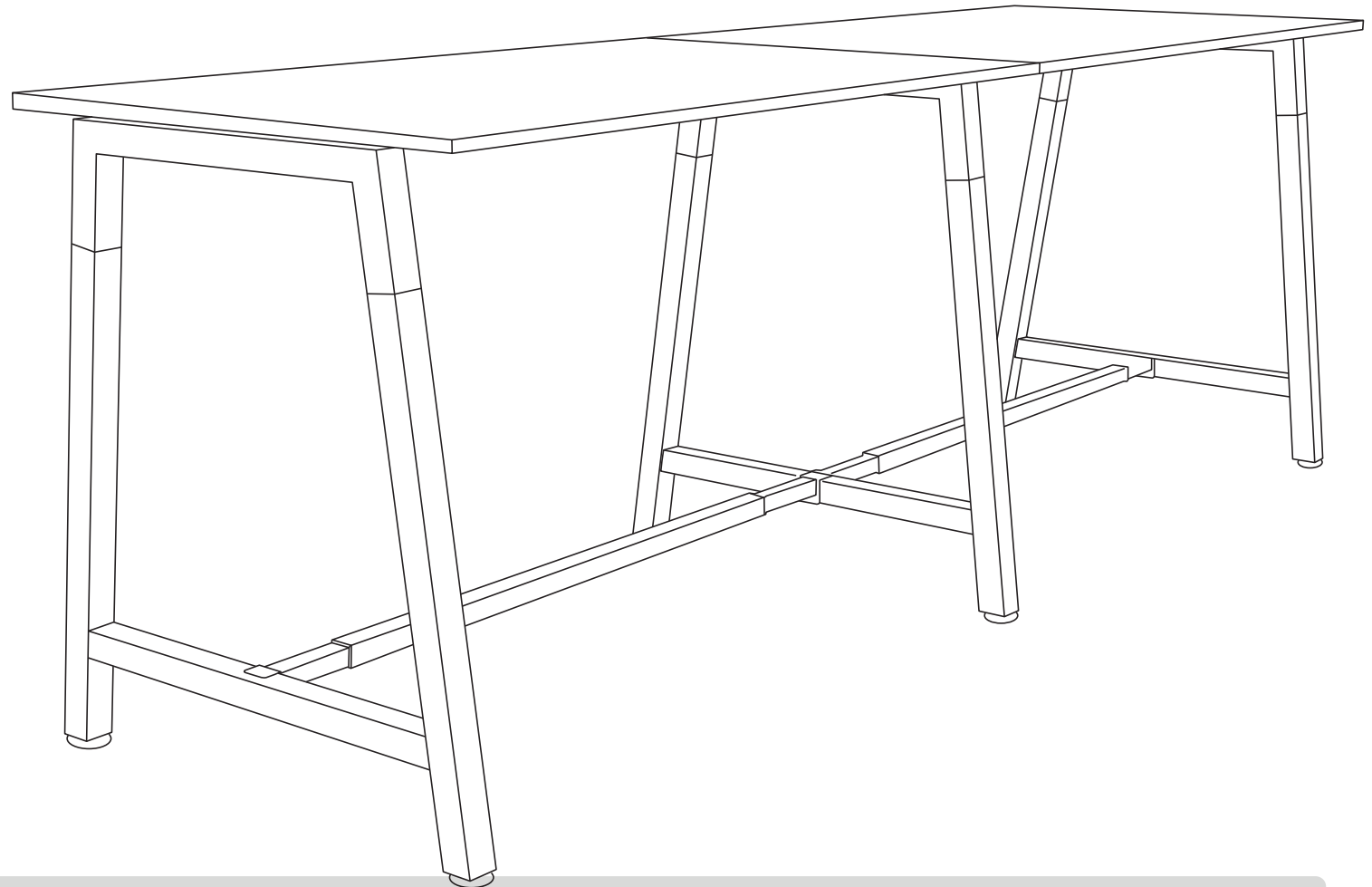

Tools Required: Power screwdriver; Allen key set (provided)

 2 persons required for installation

ASSEMBLY INSTRUCTIONS

Quadro Wood A leg Counter table with intermediate legs

www.jasonl.com.au

Need help!

Call us on
1300 527 665

jason.l
your office furniture mate



COMPONENTS

- A Table top x2
- B Leg Quadro A (Half leg cross beam) x2
- C Intermediate Leg Quadro A (Half leg cross beam) x1
- D Leg wood add on x6
- E Leg bottom beam x3
- F Upper beam x2 *
- G Lower beam x2
- H Plastic bracket x8
- I Feets or Wheels x6 **

SCREWS

- J M8x20MM CSK x12
- K M8x20MM socket head x4
- L M6x20MM socket head x8
- M M6x30MM socket head x8
- N Pins x4
- O Corner pads x6
- P Mushroom head M6x30 x6

Q Allen key x2

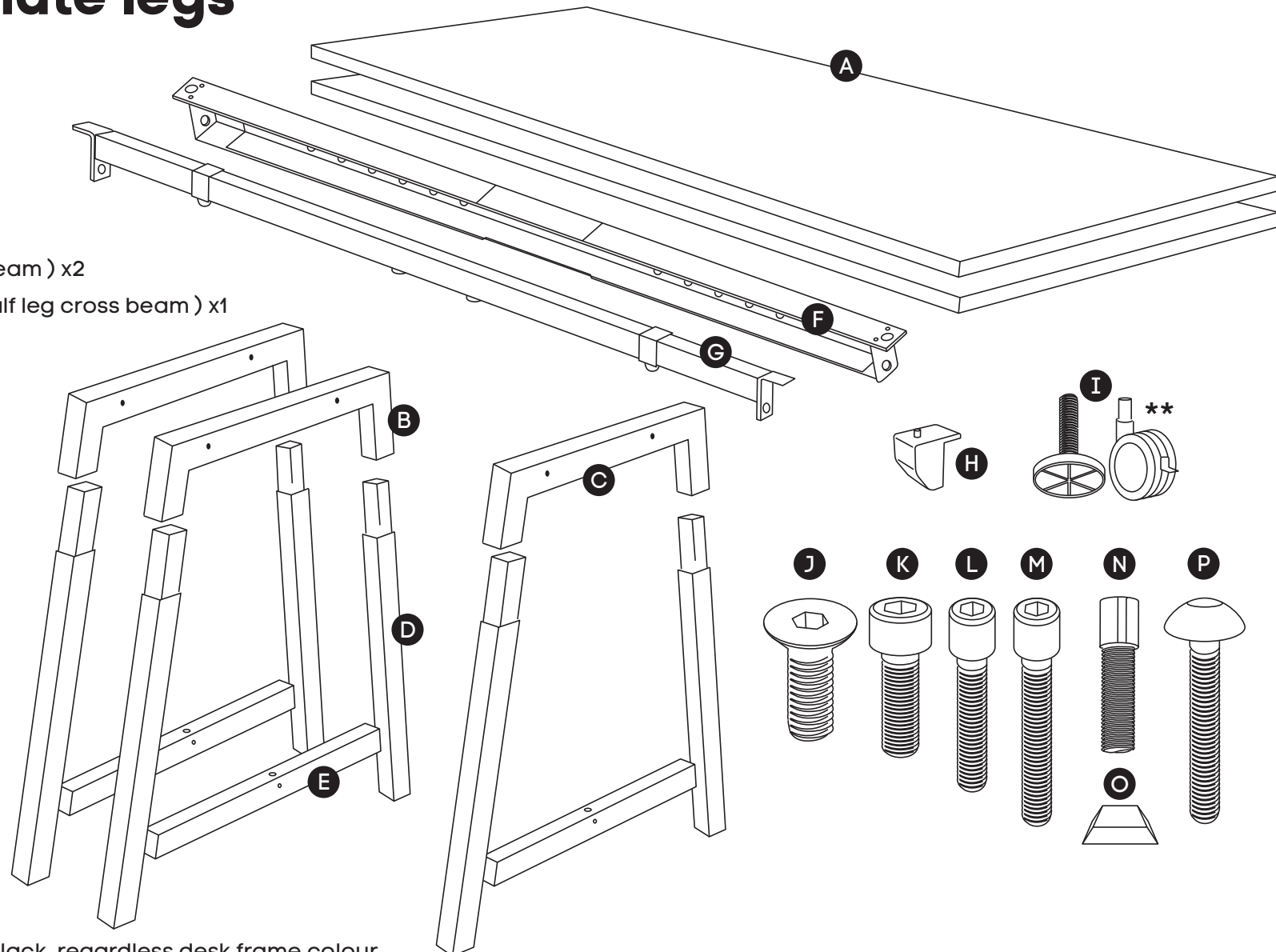

* Colour of the beam is always black, regardless desk frame colour.

** If you purchase with wheels option

ASSEMBLY INSTRUCTIONS

Quadro Wood A leg Counter table with intermediate legs

www.jasonl.com.au

Need help!

Call us on
1300 527 665

jason.l
your office furniture mate



STEP 01

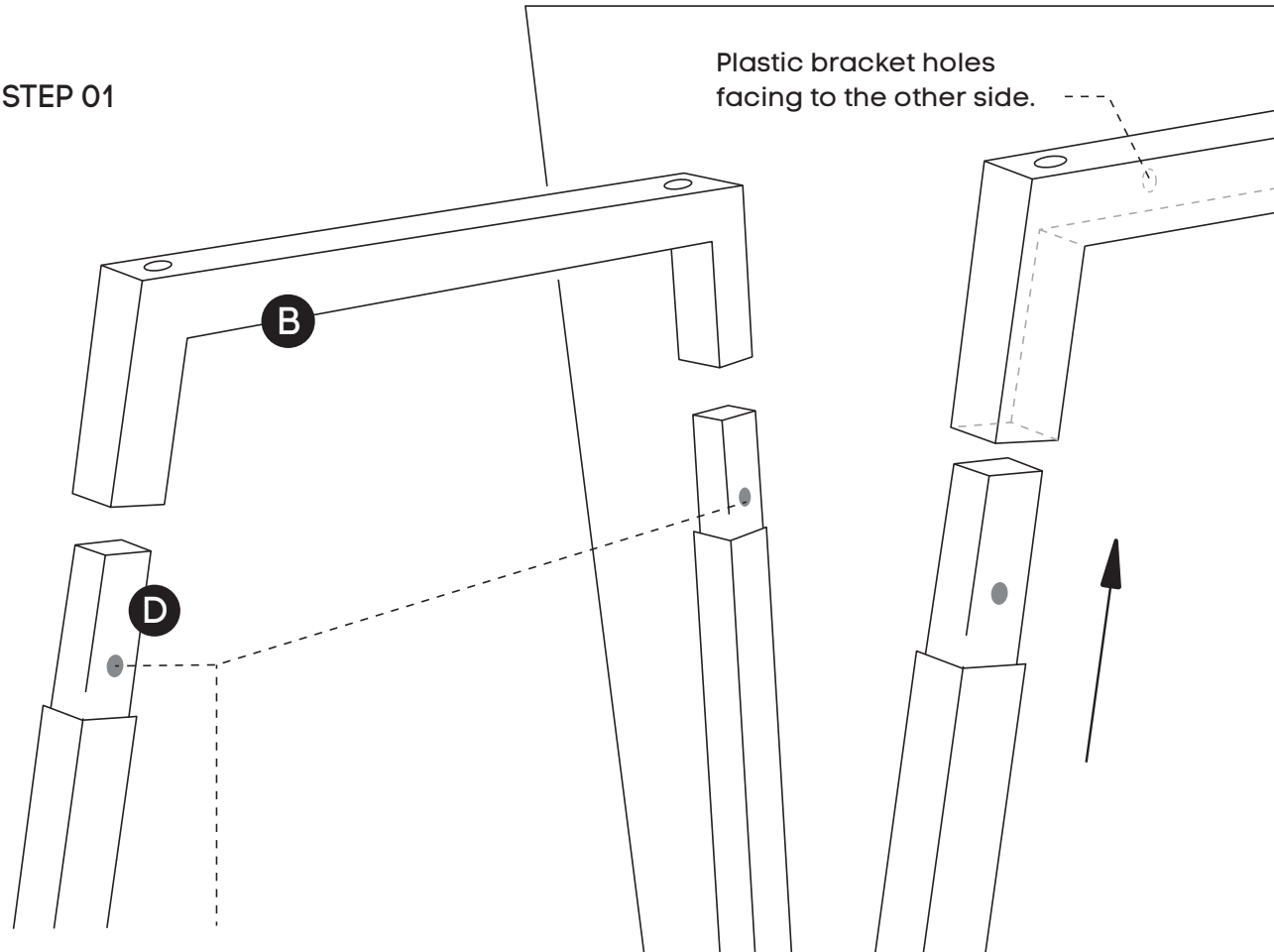

You will notice two colored stickers located on each exterior leg.

Both exterior legs must have the colour sticker facing away from where the plastic brackets are inserted.

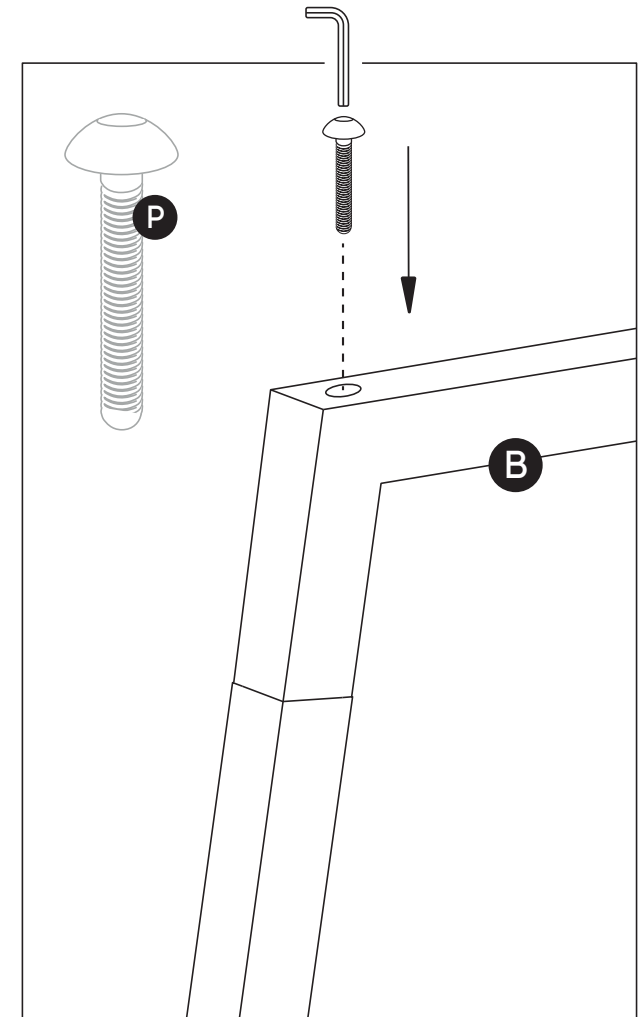

Insert the Leg wood add on (D) into the Leg Quadro A (Half leg) (B) and also intermediate leg (C). Using Allen Key provided, attach mushroom head screws (P) for all legs.

ASSEMBLY INSTRUCTIONS

Quadro Wood A leg Counter table with intermediate legs

www.jasonl.com.au

Need help!

Call us on
1300 527 665

jason.l
your office furniture mate



STEP 02

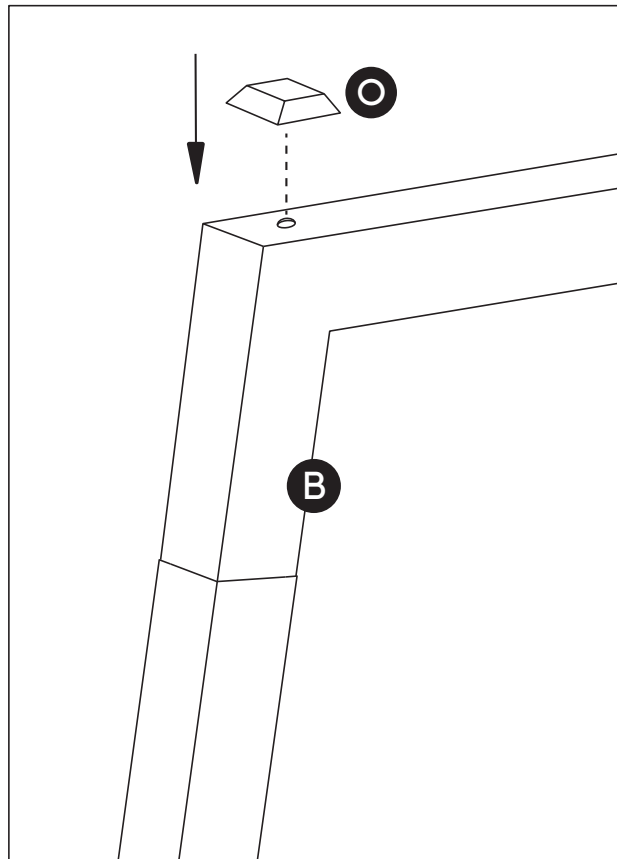

Now use corner pads **(O)** to cover the holes where just inserted the head screw sockets.

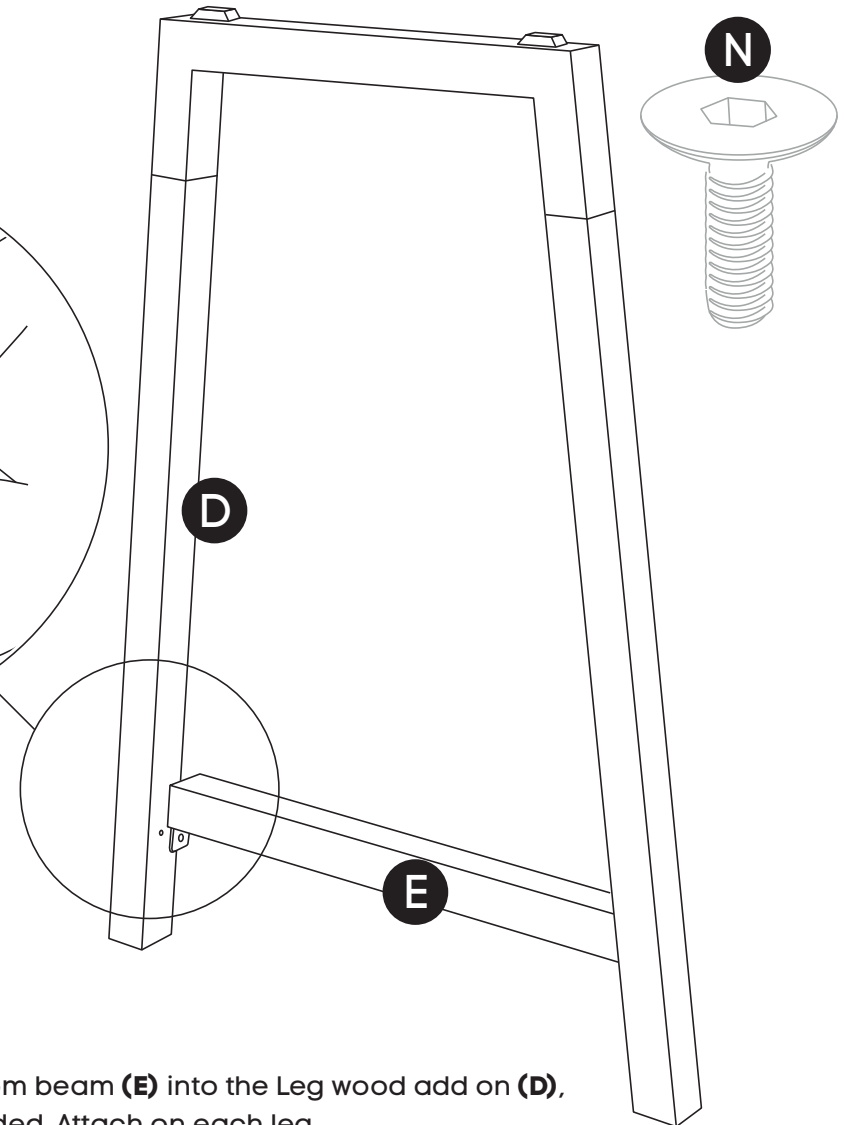
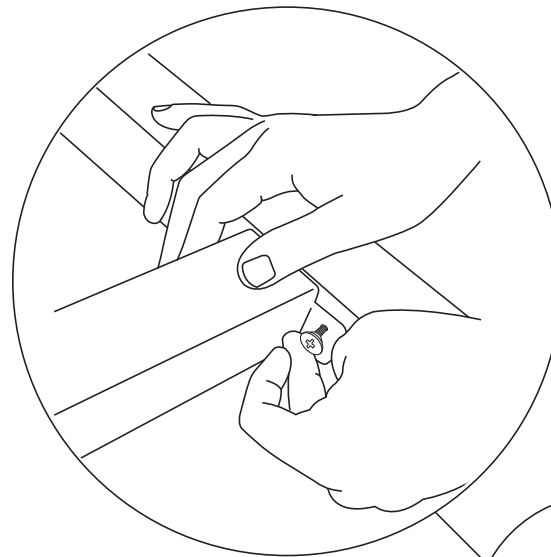

Insert the Leg bottom beam **(E)** into the Leg wood add on **(D)**, using Pins **(N)** provided. Attach on each leg.

ASSEMBLY INSTRUCTIONS

Quadro Wood A leg Counter table with intermediate legs

www.jasonl.com.au

Need help!

Call us on
1300 527 665

jason.l
your office furniture mate

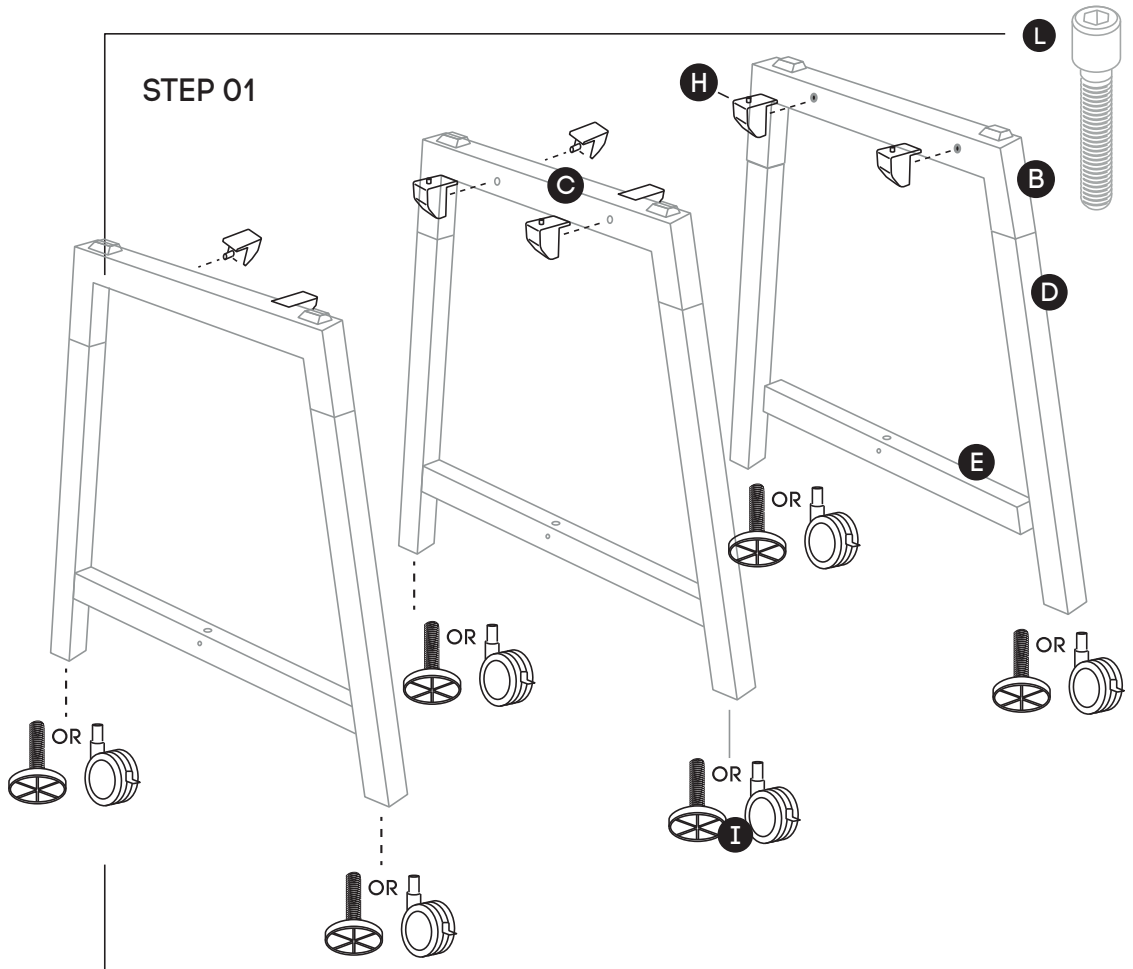

Using Allen Key provided, attach 2 plastic brackets (**H**) per exterior leg (as per picture above) using M6x20MM (**L**) Socket head screw. Attach 4 plastic brackets (**H**) to the Intermediate leg (**C**) using M6x20MM (**L**).
Screw the feet or wheels (if you purchase with wheels option) (**I**) to the bottom of each Leg wood add on (**D**).

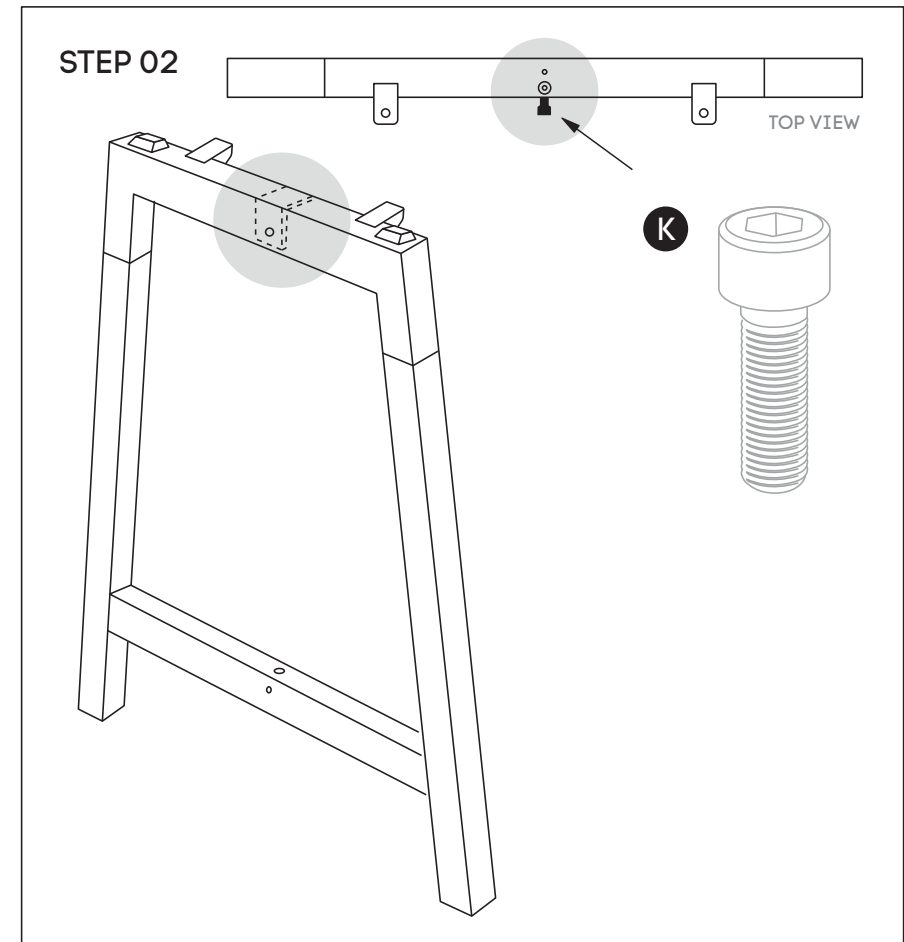

Using Allen Key provided, attach M8x20MM Socket head (**K**)-screw socket half way into legs.

ASSEMBLY INSTRUCTIONS

Quadro Wood A leg Counter table with intermediate legs

www.jasonl.com.au

Need help!

Call us on
1300 527 665

jason.l
your office furniture mate



STEP 03

Adjust extendable beams **(F)** to desired length using markers and secure beams at that length using screws provided.

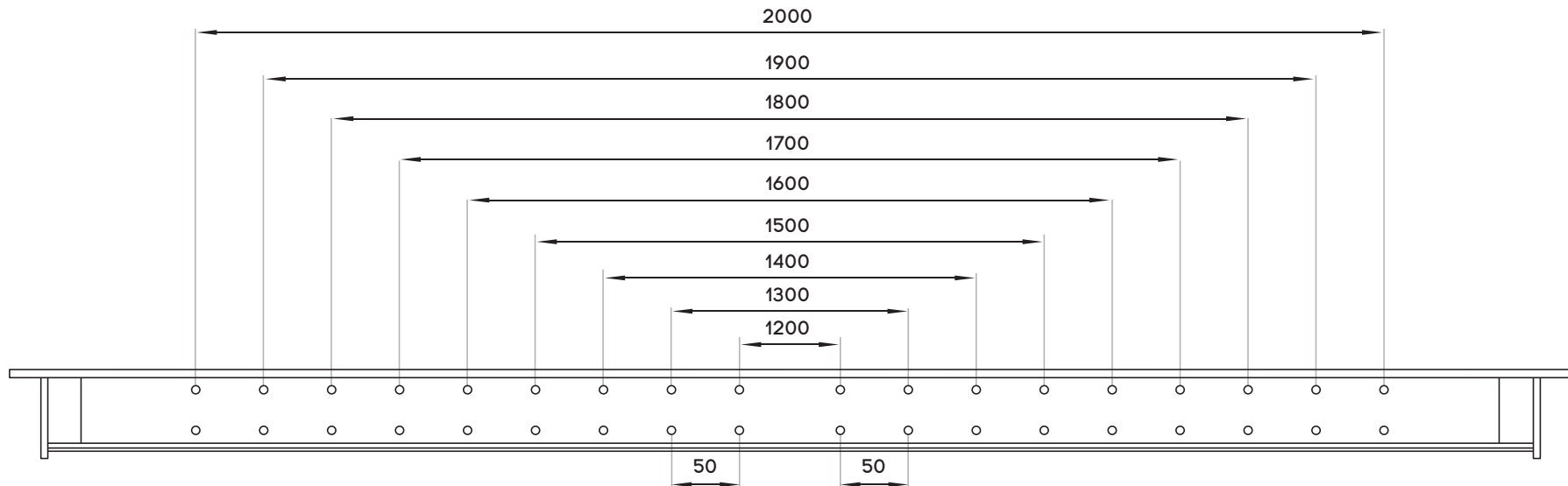
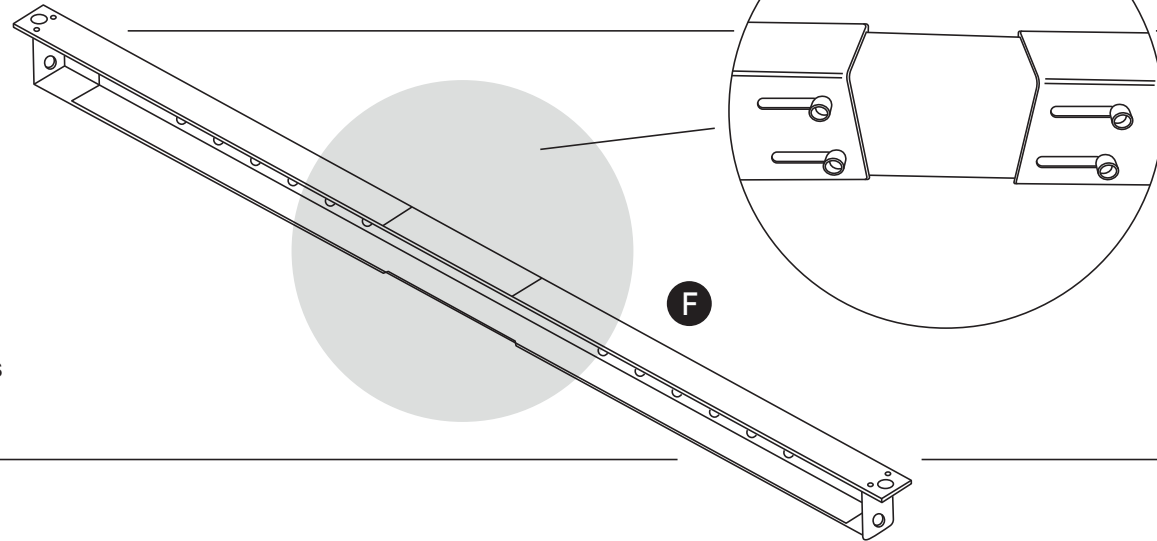

ASSEMBLY INSTRUCTIONS

Quadro Wood A leg Counter table with intermediate legs

www.jasonl.com.au

Need help!

Call us on
1300 527 665

jason.l
your office furniture mate



STEP 04

Adjust extendable beams (G) to desired length.

- 1 Remove plastic inserts
- 2 Loosen 2 bolts on beam using allen key
- 3 Extent lower beam to the same distance as upper beam
- 4 Insert plastic inserts back into the beams

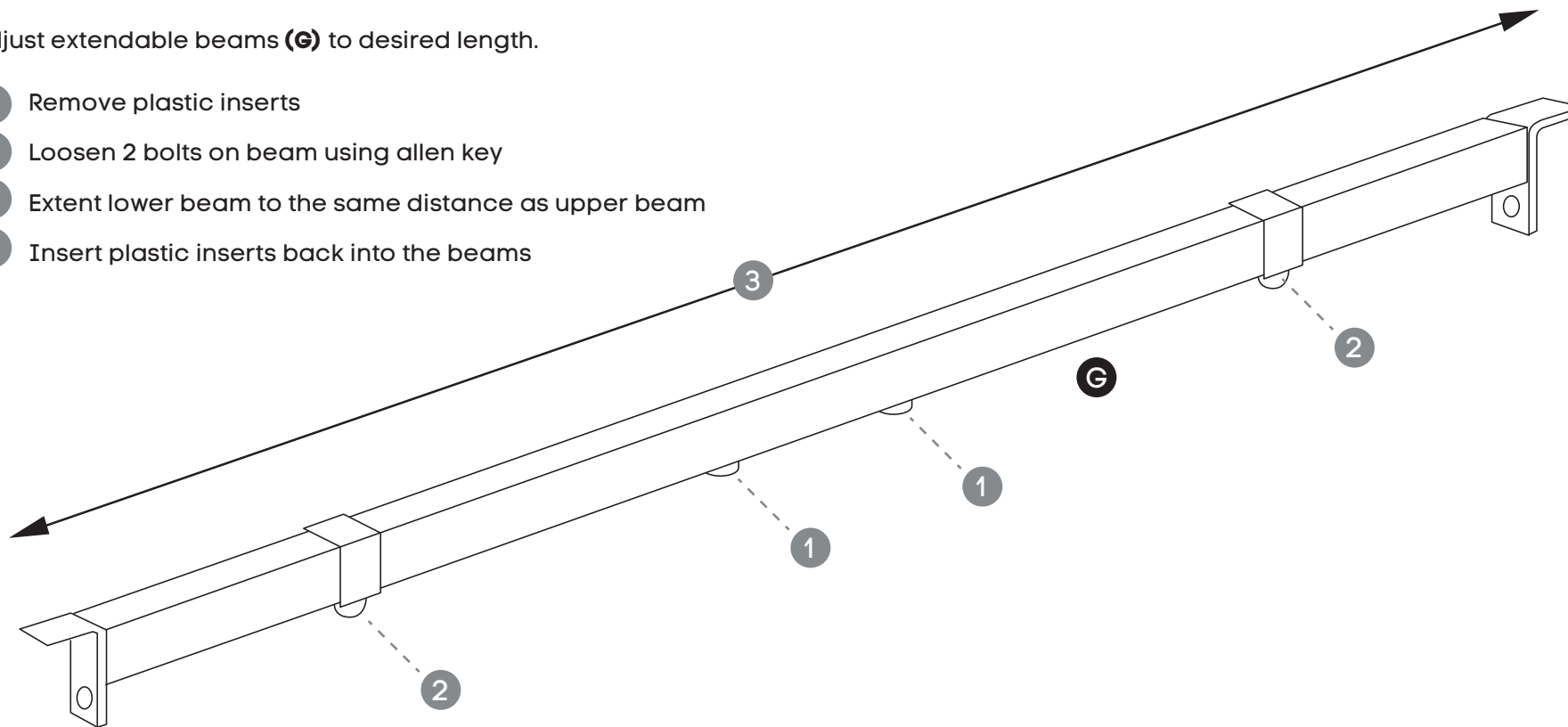

ASSEMBLY INSTRUCTIONS

Quadro Wood A leg Counter table with intermediate legs

www.jasonl.com.au

Need help!

Call us on
1300 527 665

jason.l
your office furniture mate

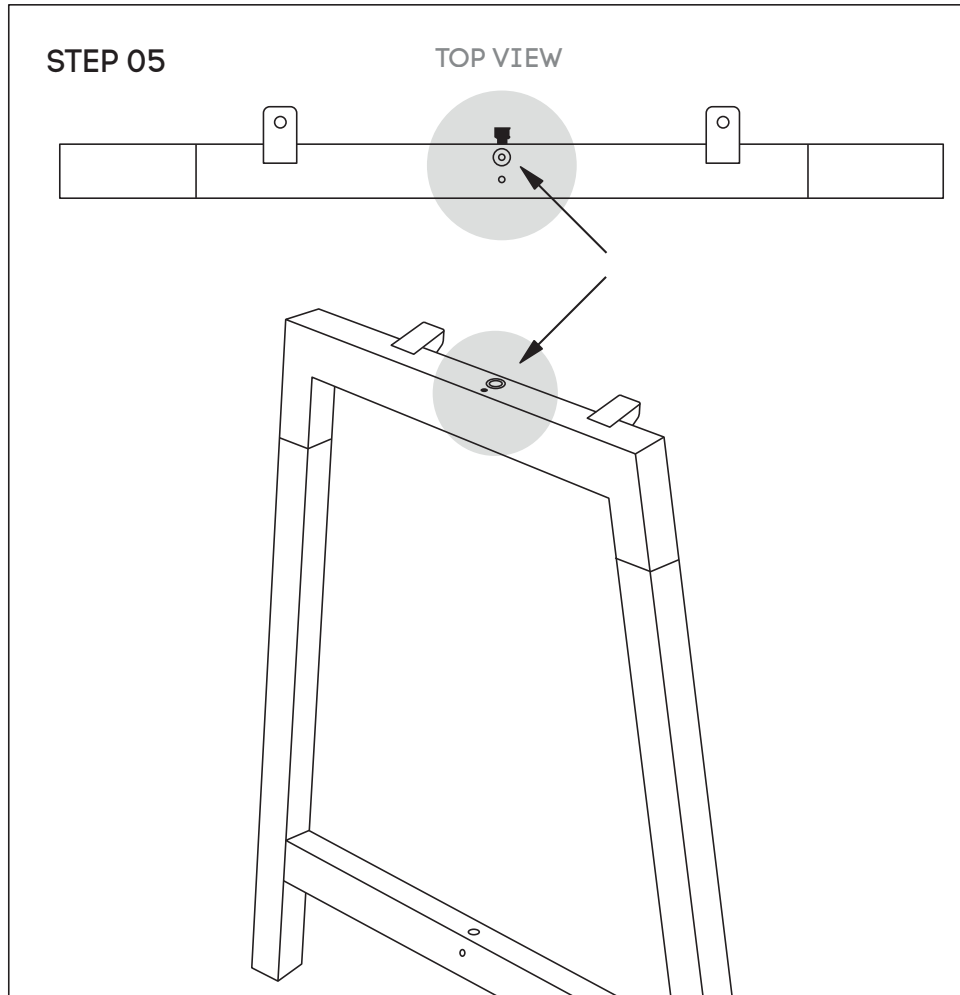

Attach Upper Beams (**F**) to legs using nut insert.
See point attached

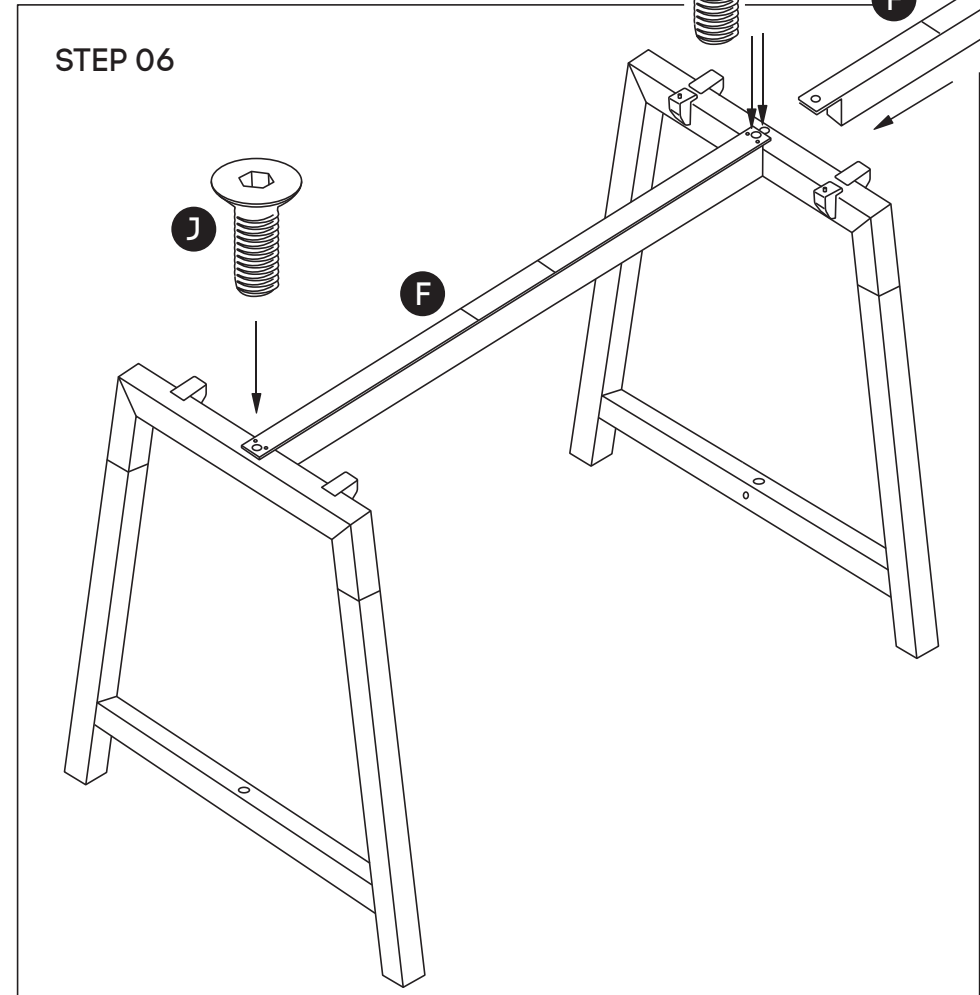

Frame looks like this. Using Allen Key, attach Upper Beams (**F**) with Sockets (**J**).

ASSEMBLY INSTRUCTIONS

Quadro Wood A leg Counter table with intermediate legs

www.jasonl.com.au

Need help!

Call us on
1300 527 665

jason.l
your office furniture mate



STEP 07

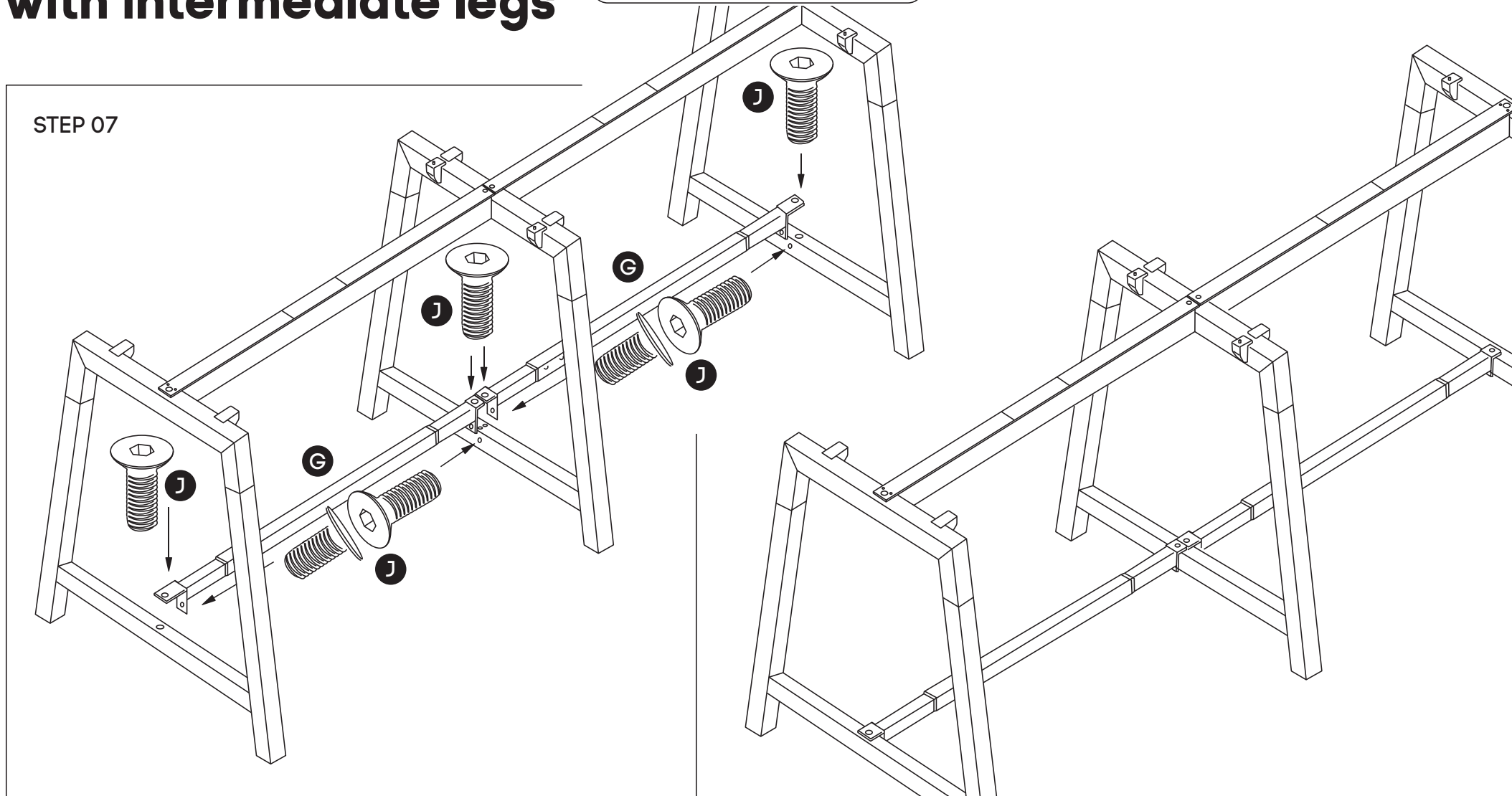

Using Allen Key. Tighten Sockets (J) on the Lower Beam (G) using Allen Key (Q). Insert plastic spacers to improve rigidity. Attach two Sockets (J) to the side of the lower side beams (as shown in the picture).

Frame looks like this.

ASSEMBLY INSTRUCTIONS

Quadro Wood A leg Counter table with intermediate legs

www.jasonl.com.au

Need help!

Call us on
1300 527 665

jason.l
your office furniture mate

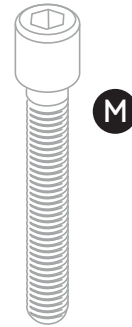
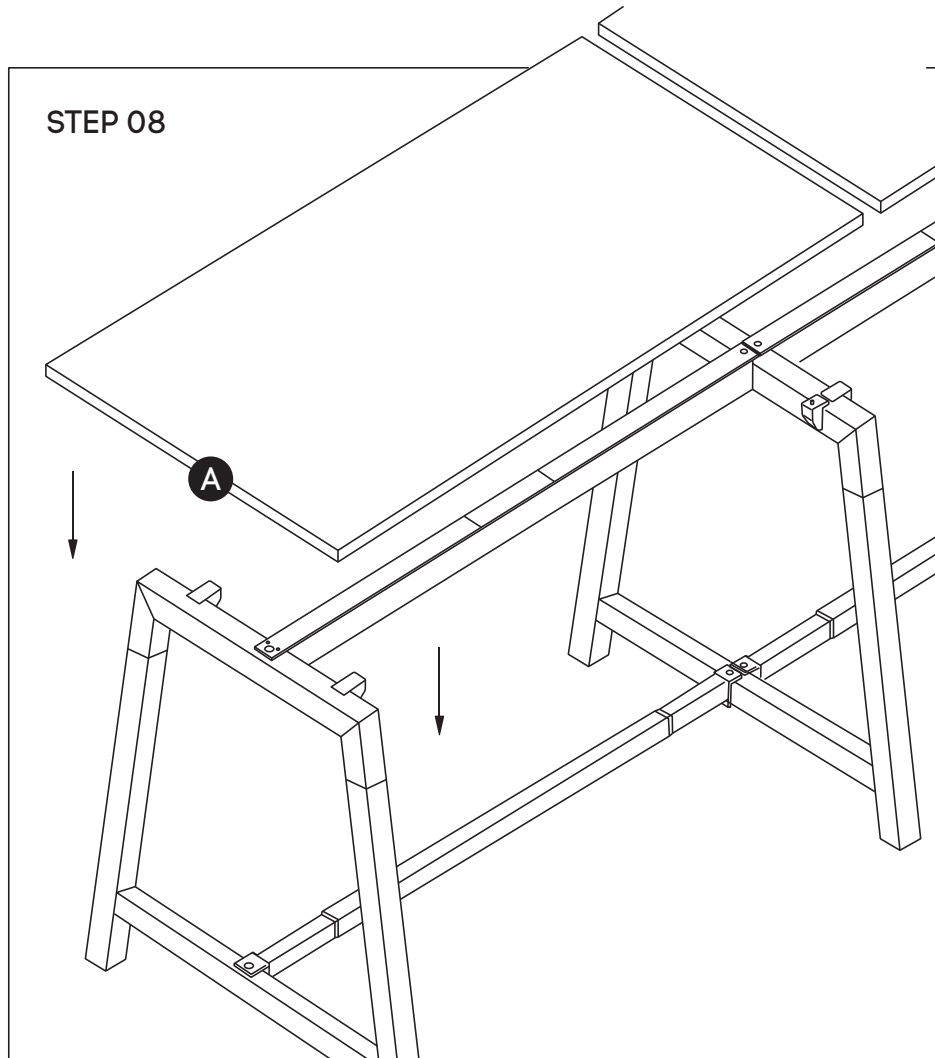
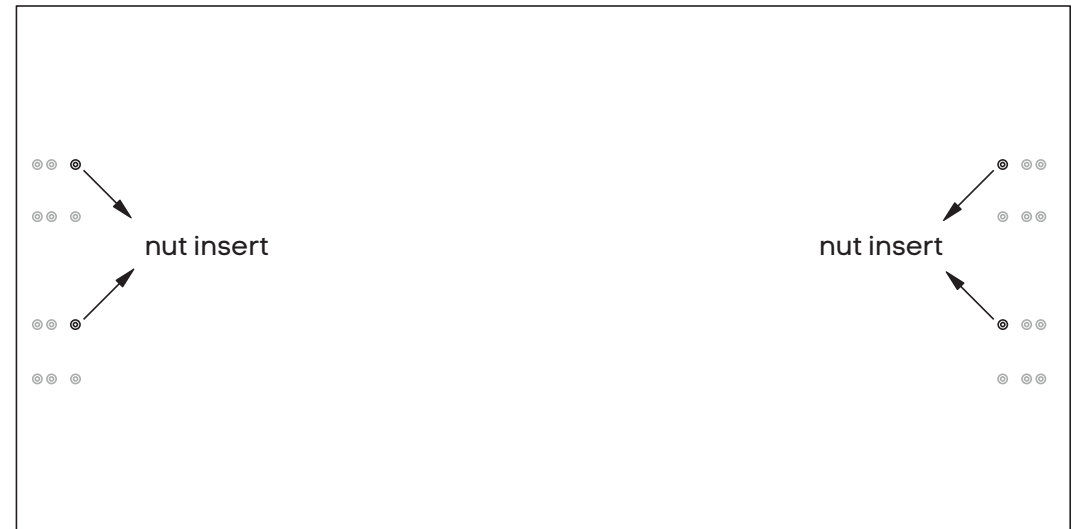

TABLE TOP
BOTTOM VIEW



Place desktops **(A)** on top of frames. Nut inserts in top will align with plastic joiner brackets using M6x30MM **(M)** sockets attached tops to frames.