

ASSEMBLY INSTRUCTIONS
**Quadro Square leg
Counter table
Radius Corners**

www.jasonl.com.au

Need help!
Call us on
1300 527 665

jason.l
your office furniture mate



Sizes: 1100x1100 mm

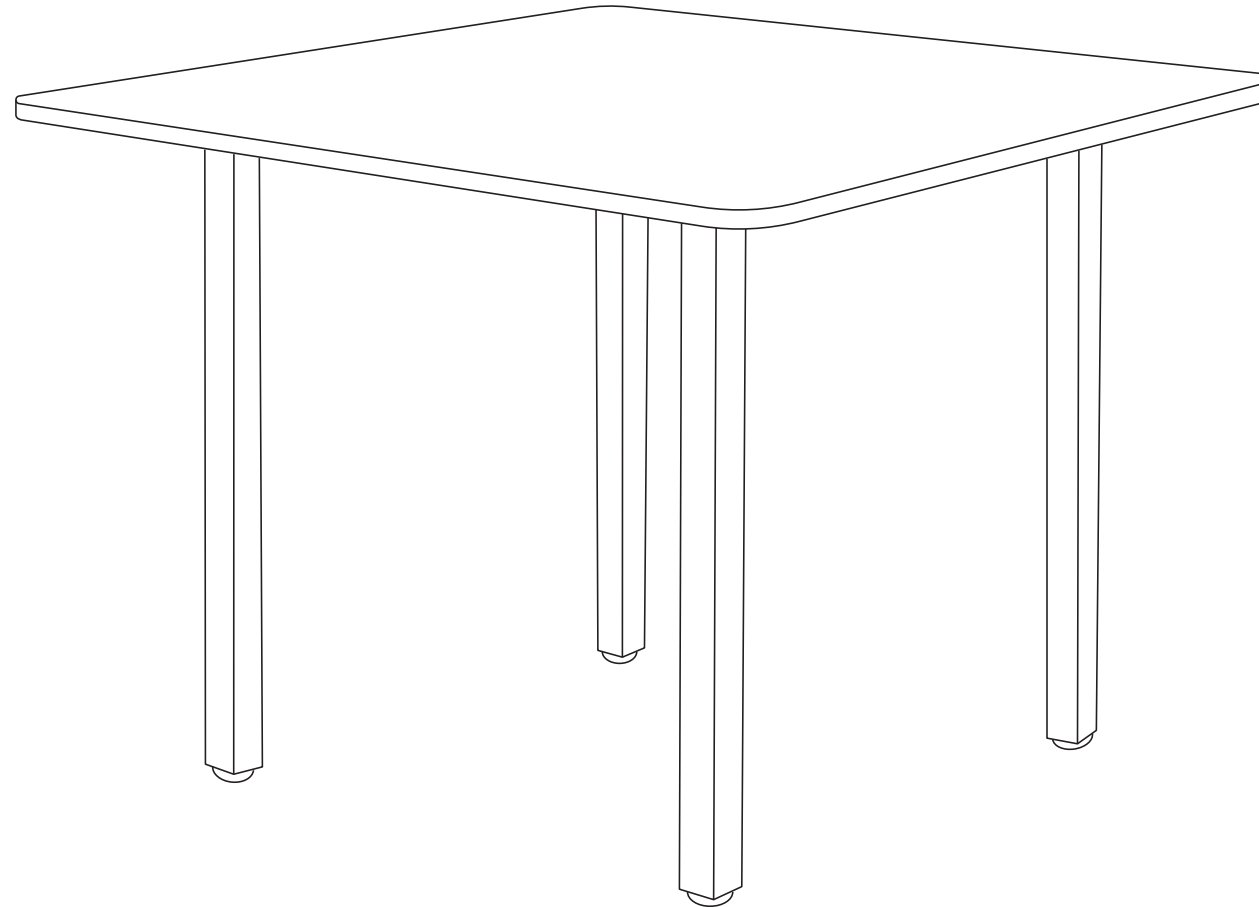

Tools Required: Power screwdriver; Allen key set (provided)

 2 persons required for installation

ASSEMBLY INSTRUCTIONS

Quadro Square leg Counter table Radius Corners

www.jasonl.com.au

Need help!

Call us on
1300 527 665

jason.l
your office furniture mate



Sizes: 1100x1100 mm

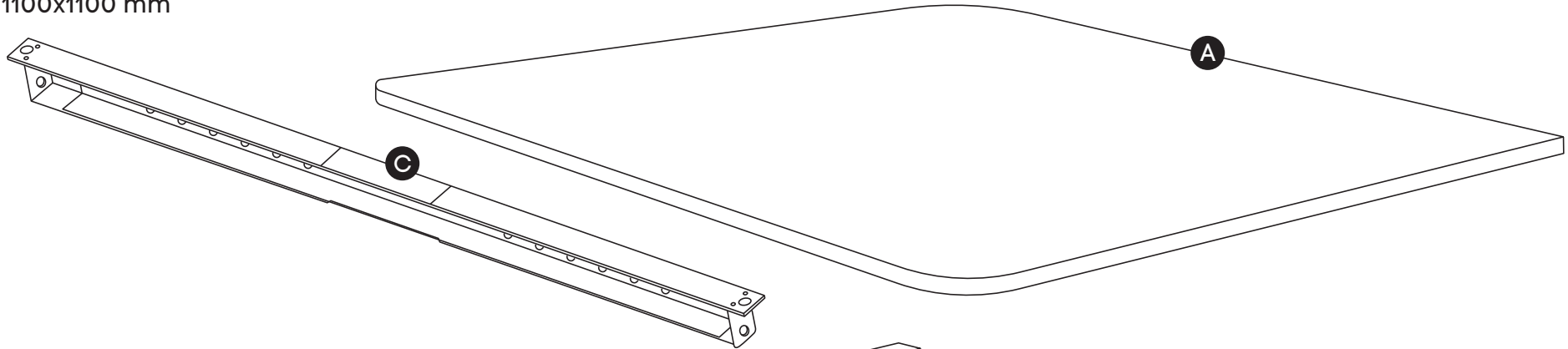

COMPONENTS

- A Table top x1
- B Leg Quadro Square x2
- C Beam x1 *
- D Plastic bracket x4

SCREWS

- E M8x20MM CSK x2
- F M8x20MM Socket head x2
- G M6x20MM Socket head x4
- H M6x30mm Socket head x 4

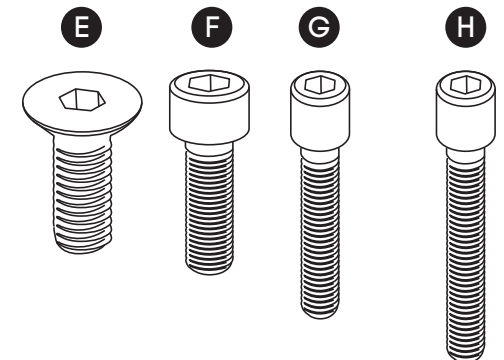
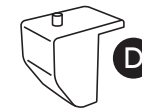
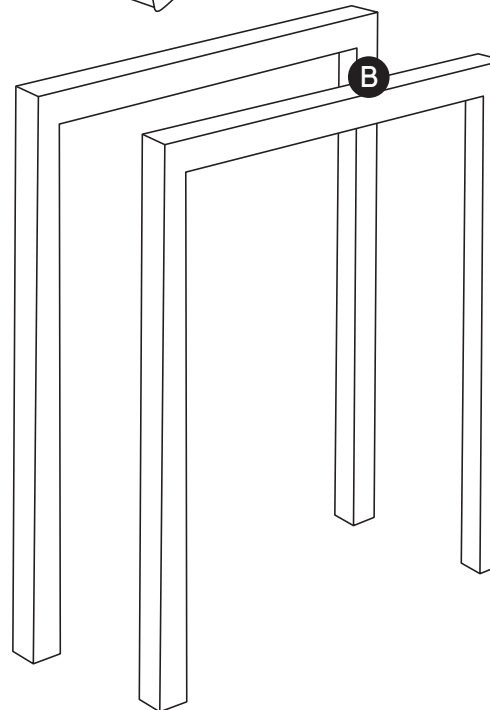

I Allen key x2

* Colour of the beam is always black, regardless desk frame colour.

ASSEMBLY INSTRUCTIONS

Quadro Square leg Counter table Radius Corners

www.jasonl.com.au

Need help!

Call us on
1300 527 665

jason.l
your office furniture mate



Sizes: 1100x1100 mm

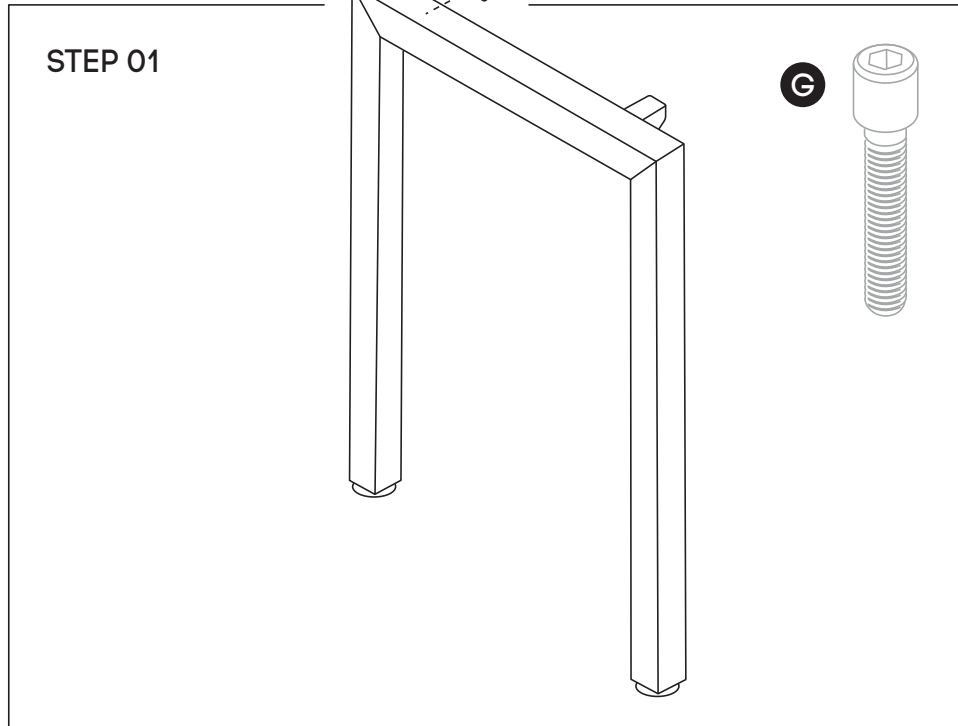

Using Allen Key provided, attach 2 plastic brackets per leg **(D)**
(as per picture above) using M6x20MM **(G)** Socket head screw

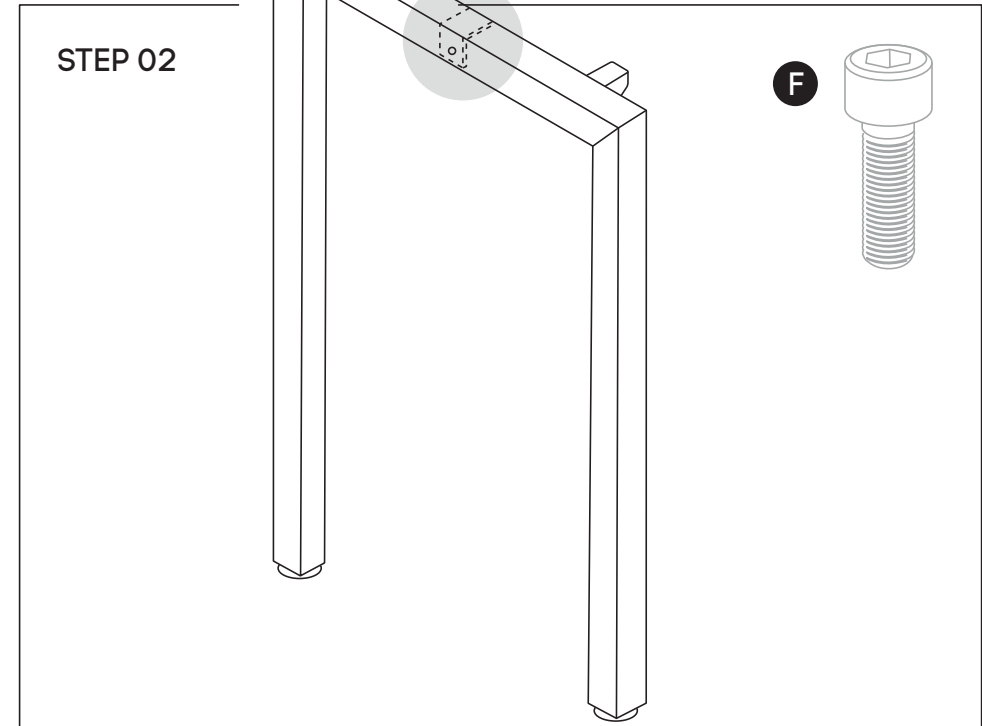

Using Allen Key provided, attach M8x20MM Socket head **(F)**-
screw socket half way into leg for both legs **(B)**

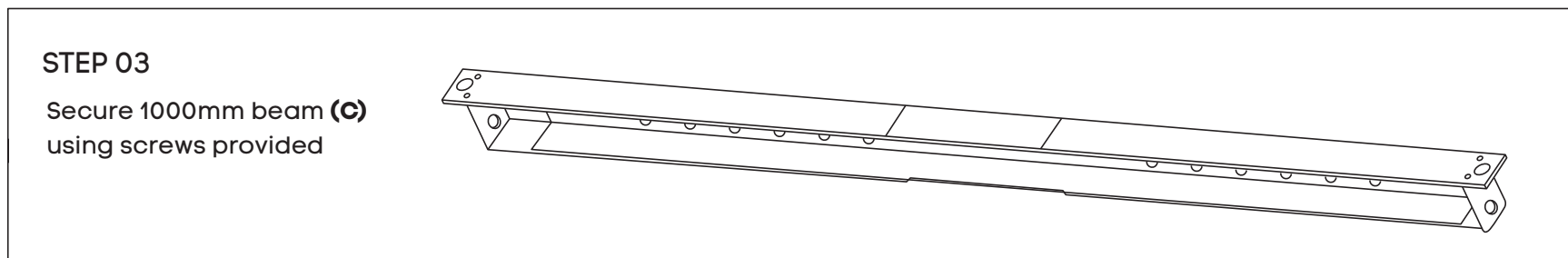

ASSEMBLY INSTRUCTIONS

Quadro Square leg Counter table Radius Corners

www.jasonl.com.au

Need help!

Call us on
1300 527 665

jason.l
your office furniture mate



Sizes: 1100x1100 mm

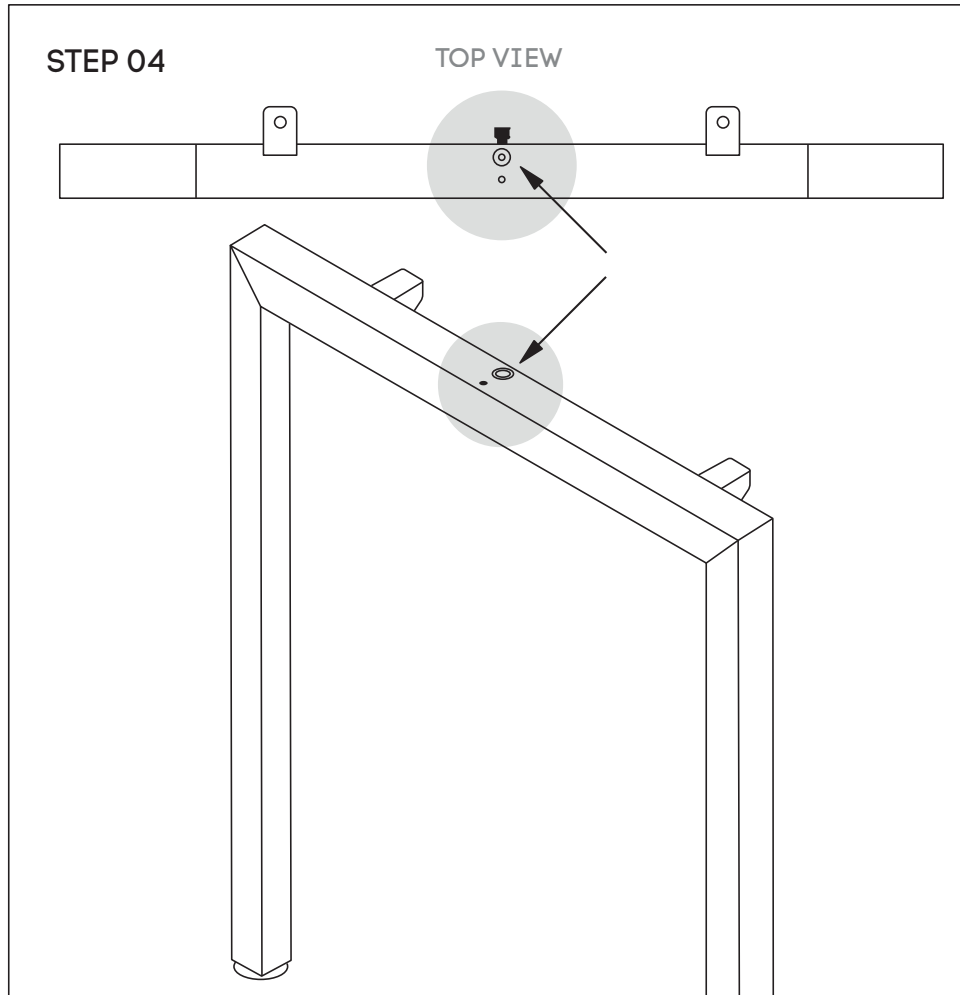
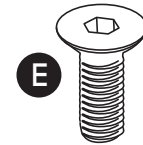

Attach beam **(C)** to legs **(B)** using nut insert in legs.
See point attached

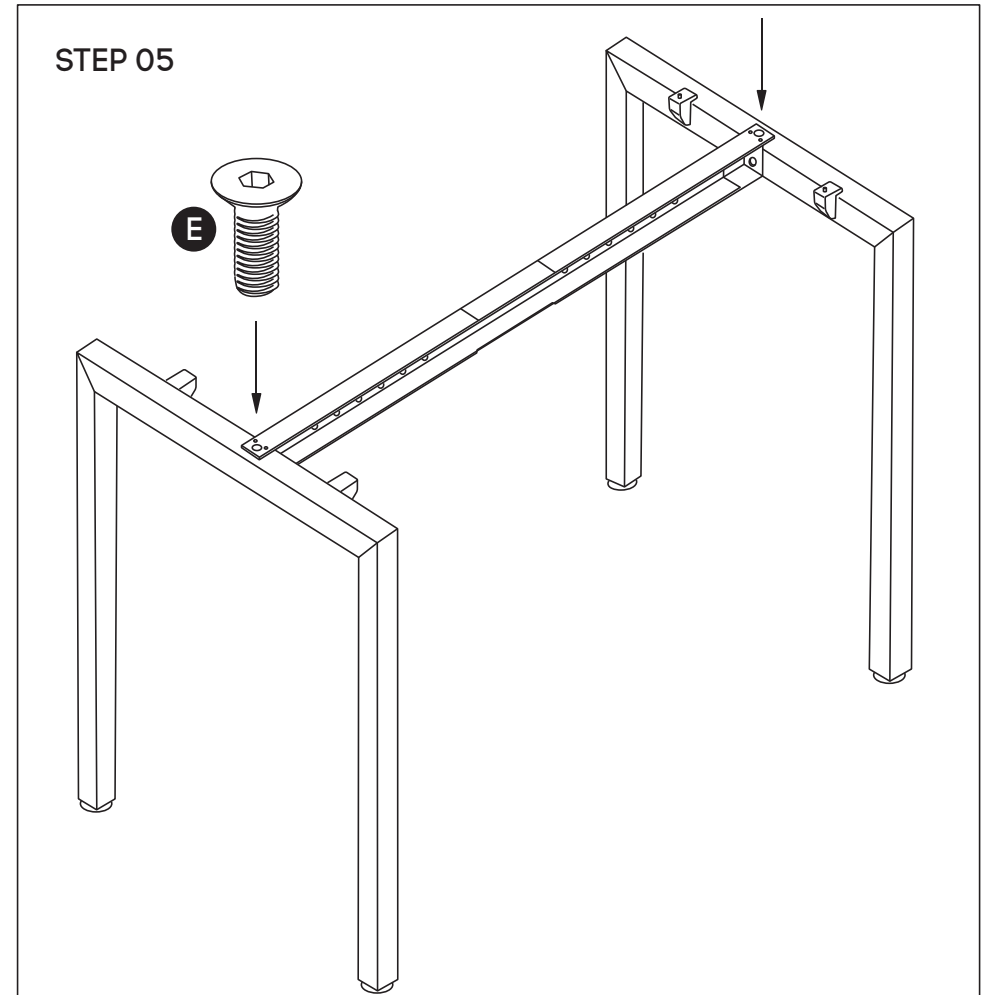

Frame looks like this. Using Allen Key, attach beam **(C)** with Socket **(E)**

ASSEMBLY INSTRUCTIONS

Quadro Square leg Counter table Radius Corners

www.jasonl.com.au

Need help!

Call us on
1300 527 665

jason.l
your office furniture mate



Sizes: 1100x1100 mm

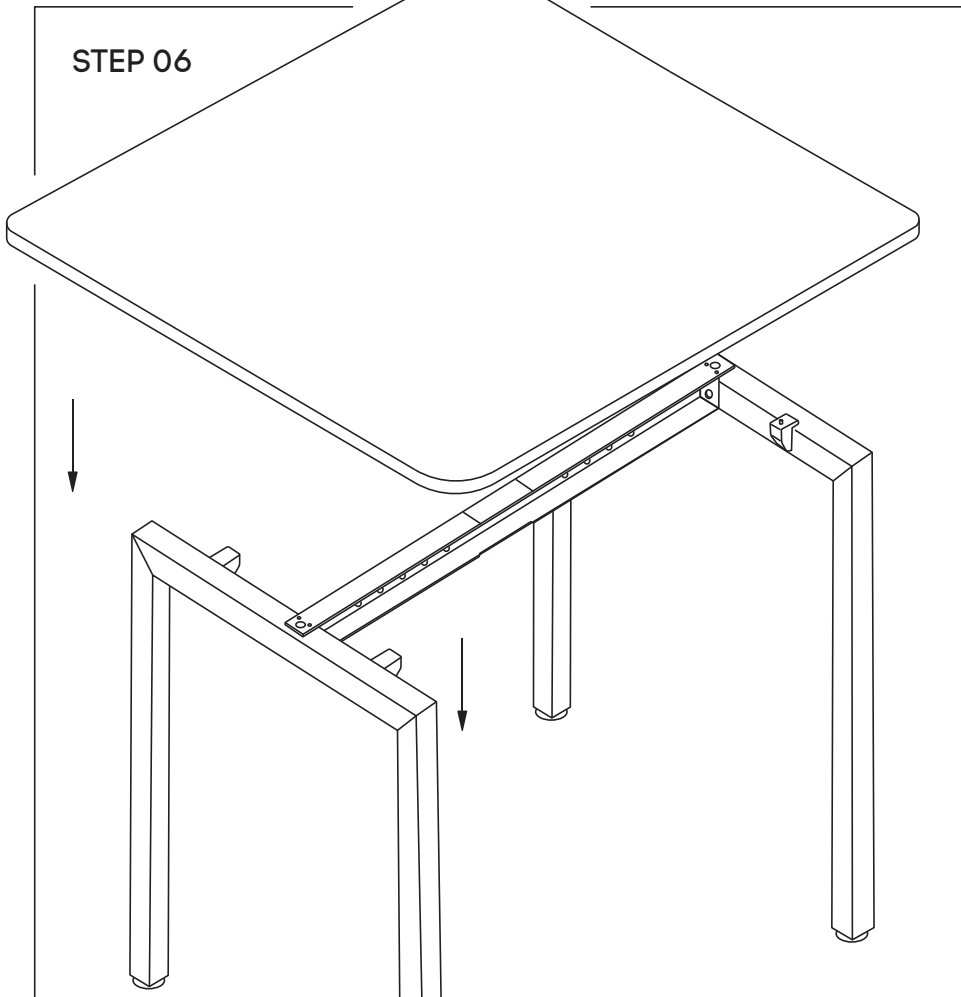

Place desktop on top of the frame. Please place the top equally centred at the same distance from left and right of the leg frame and then please tighten screws using M6x30MM (H) into the underneath of the tops.

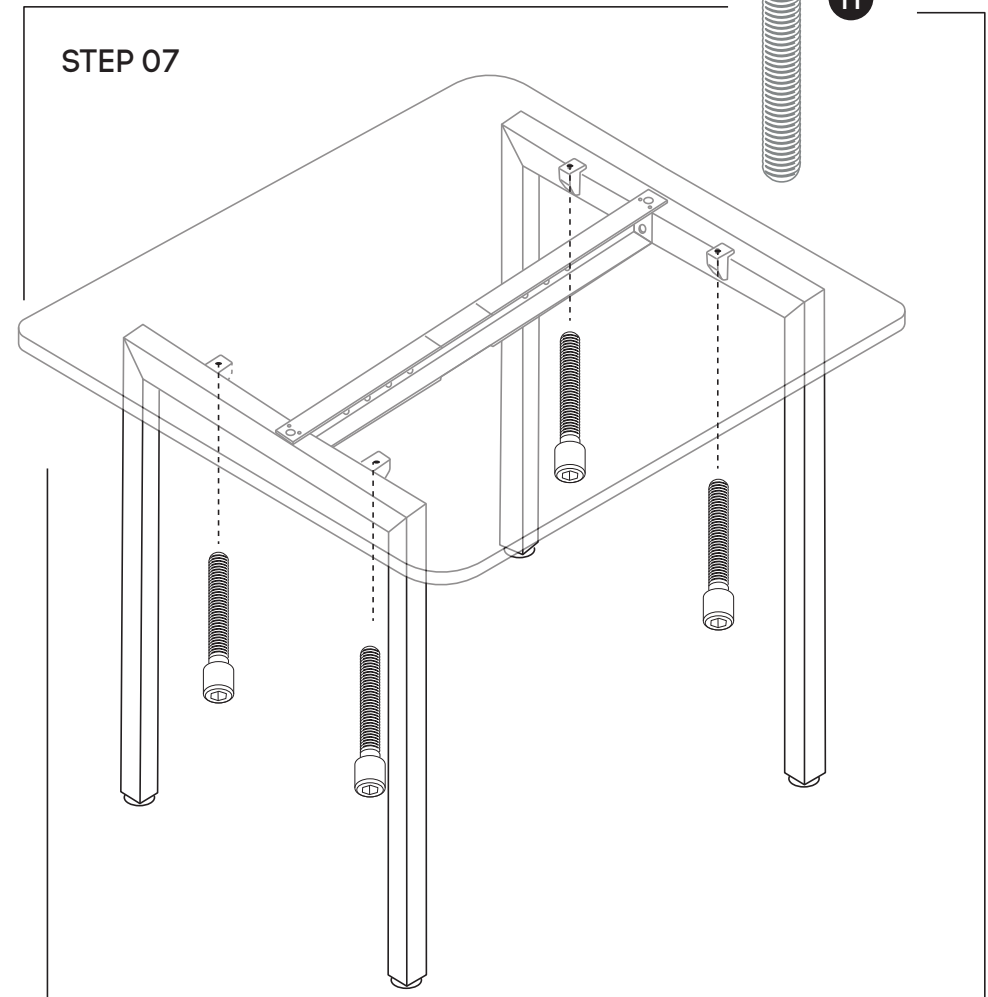

Please tighten (H) M6x30mm screws