

ASSEMBLY INSTRUCTIONS

Quadro Loop 2P workstation

Sizes: 1200, 1400, 1600, 1800 mm

www.jasonl.com.au

Need help!

Call us on
1300 527 665

jason.l
your office furniture mate

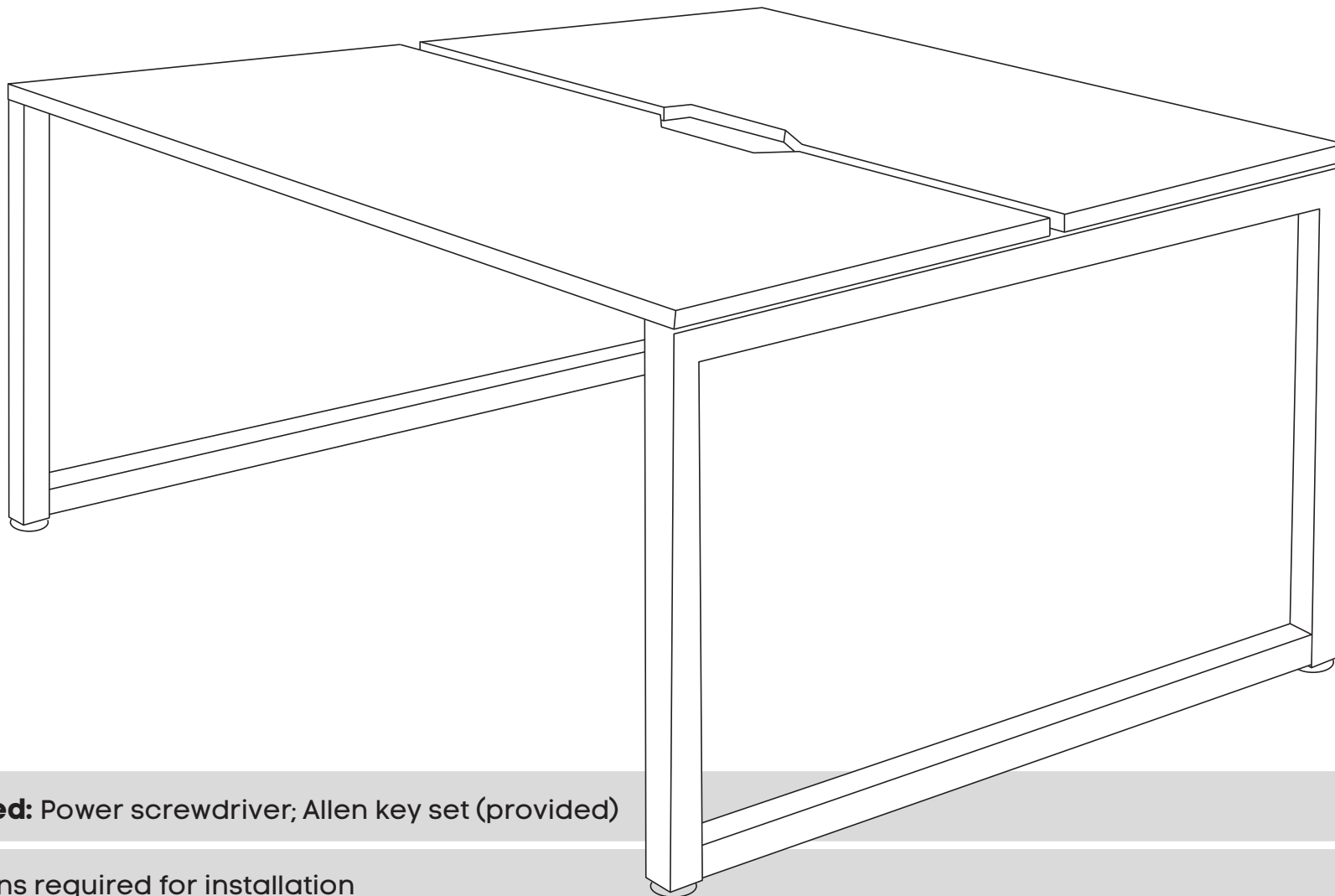

Tools Required: Power screwdriver; Allen key set (provided)

 2 persons required for installation

ASSEMBLY INSTRUCTIONS

Quadro Loop 2P workstation

Sizes: 1200, 1400, 1600, 1800 mm

www.jasonl.com.au

Need help!

Call us on
1300 527 665

jason.l
your office furniture mate

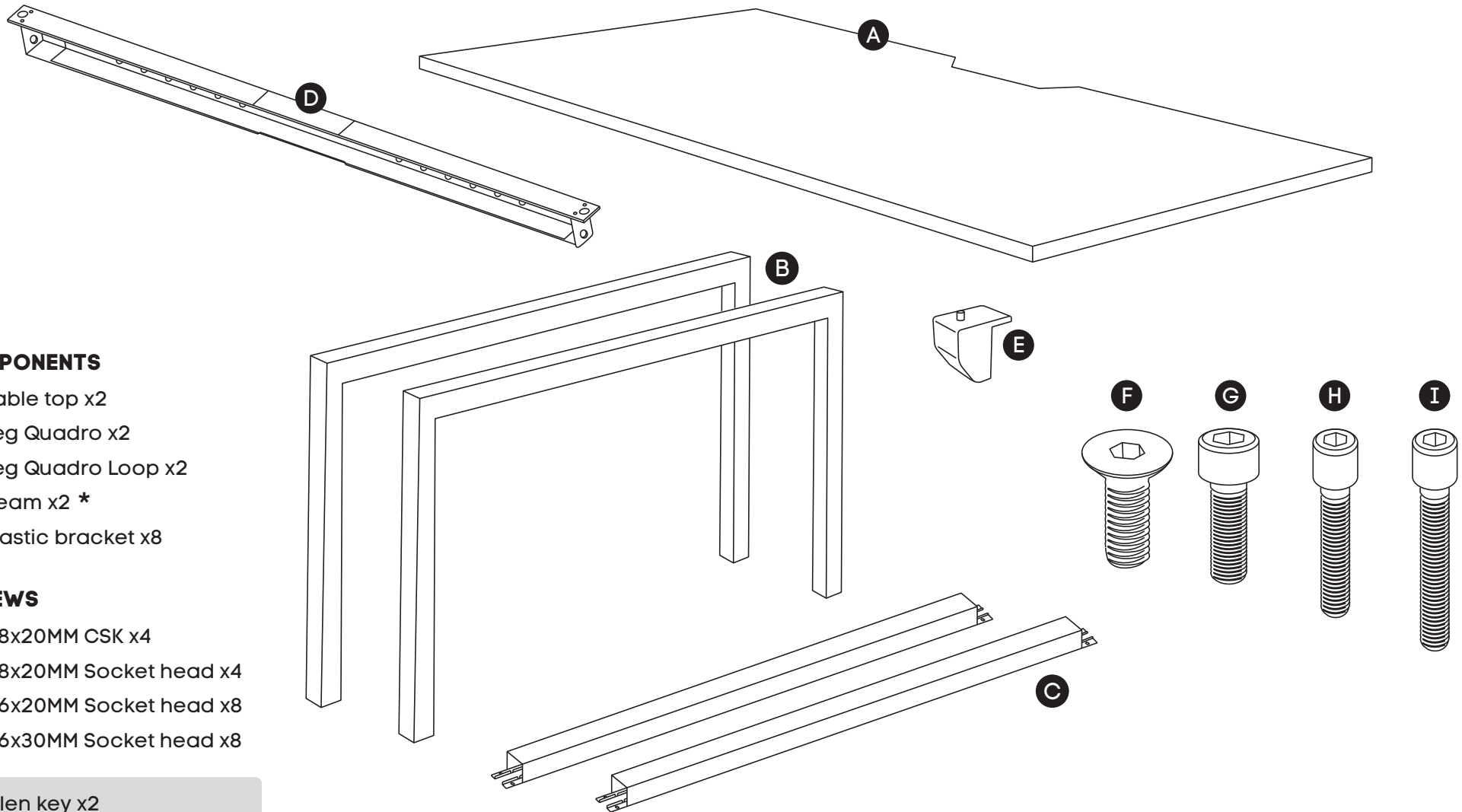

COMPONENTS

- A Table top x2
- B Leg Quadro x2
- C Leg Quadro Loop x2
- D Beam x2 *
- E Plastic bracket x8

SCREWS

- F M8x20MM CSK x4
- G M8x20MM Socket head x4
- H M6x20MM Socket head x8
- I M6x30MM Socket head x8

- J Allen key x2

* Colour of the beam is always black, regardless desk frame colour.

ASSEMBLY INSTRUCTIONS

Quadro Loop 2P workstation

Sizes: 1200, 1400, 1600, 1800 mm

www.jasonl.com.au

Need help!

Call us on
1300 527 665

jason.l
your office furniture mate

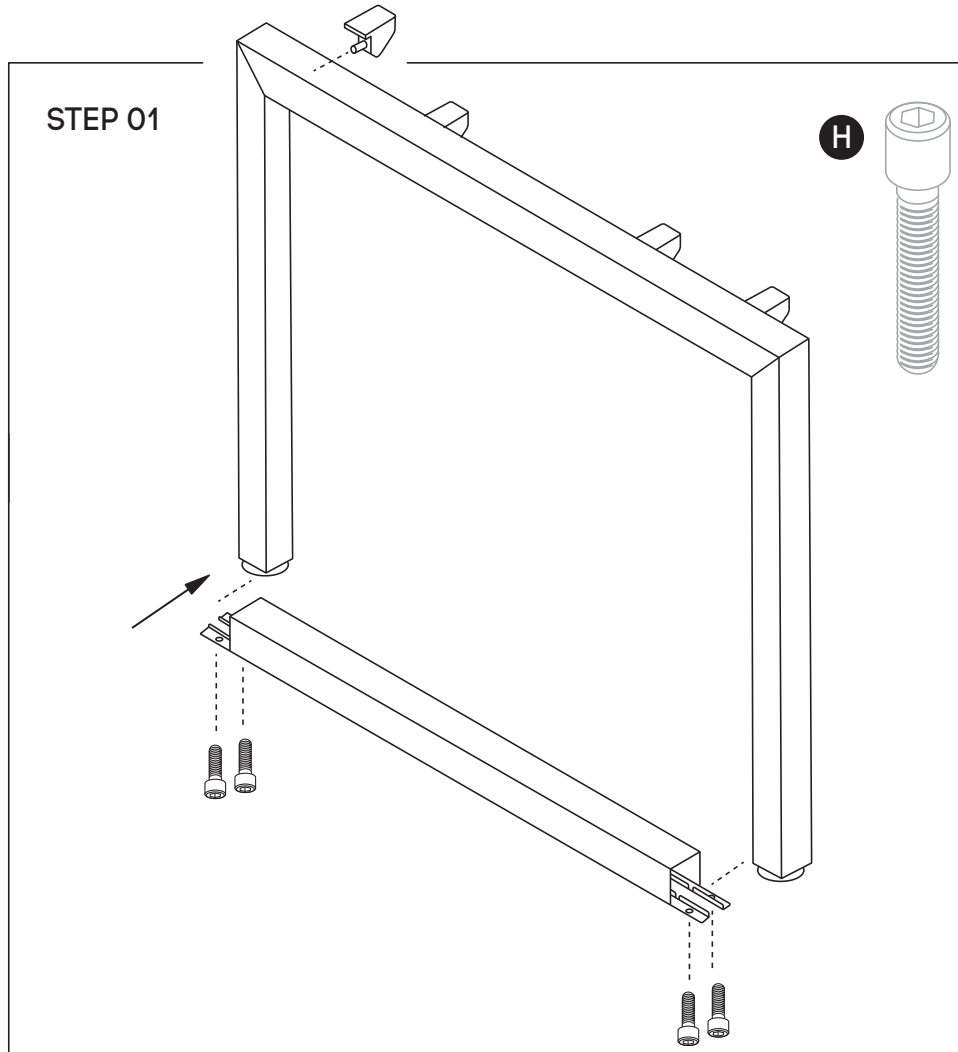

Using Allen Key provided, attach 4 plastic brackets per leg (E) (as per picture above) using M6x20MM (H) Socket head screw. Connect Loop Legs (C) to Bottom of Quadro Legs (B) by using 4 bolts per leg

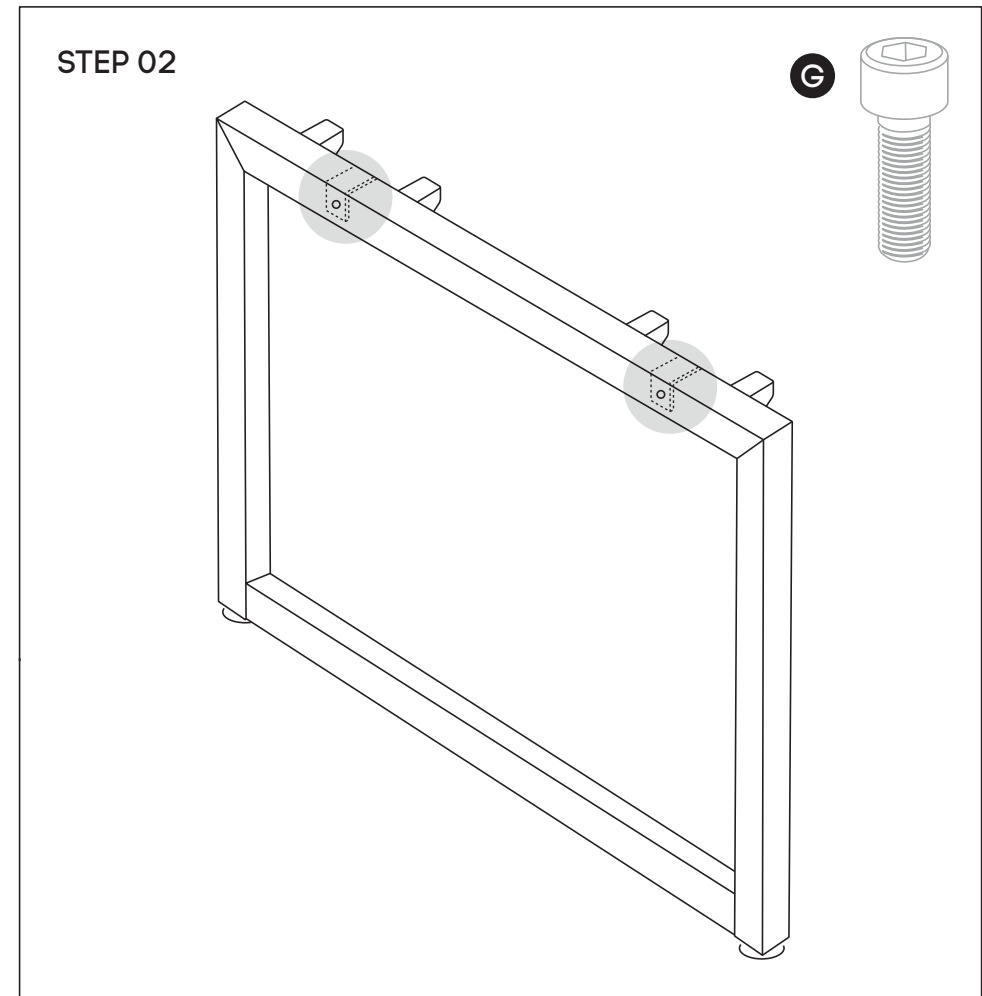

Using Allen Key provided, attach M8x20MM Socket head (G)-screw socket half way into leg for both legs (B).

ASSEMBLY INSTRUCTIONS

Quadro Loop 2P workstation

www.jasonl.com.au

Need help!
Call us on
1300 527 665

jason.l
your office furniture mate



Sizes: 1200, 1400, 1600, 1800 mm

STEP 03

Adjust extendable beam **(D)** to desired length using markers and secure beam at that length using screws provided

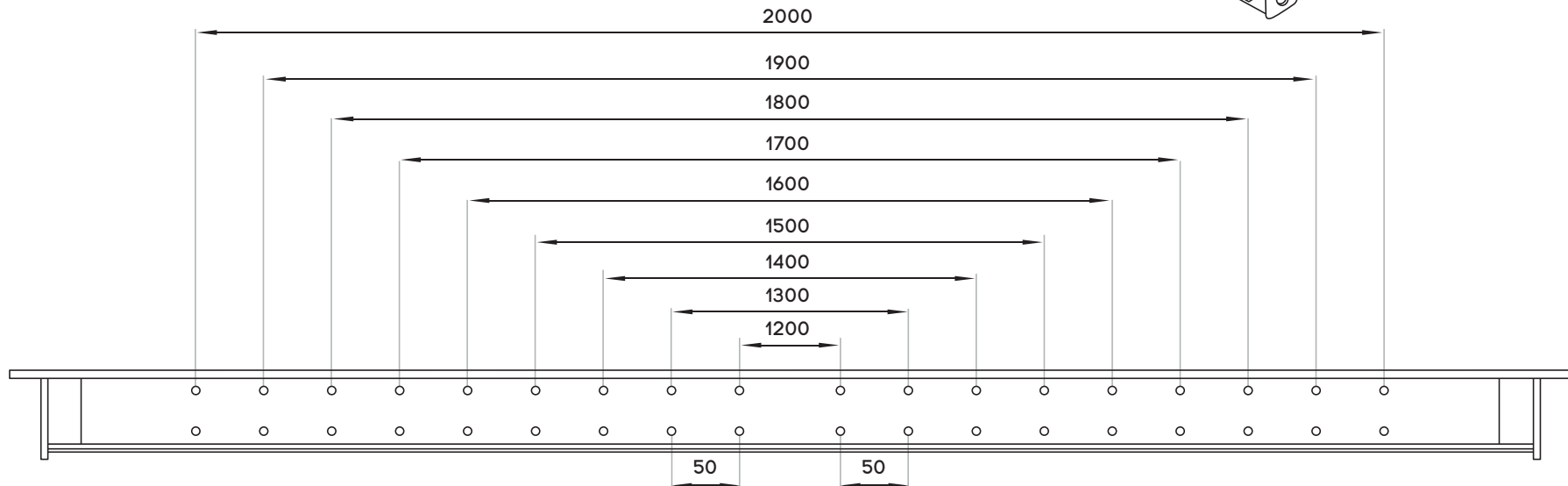
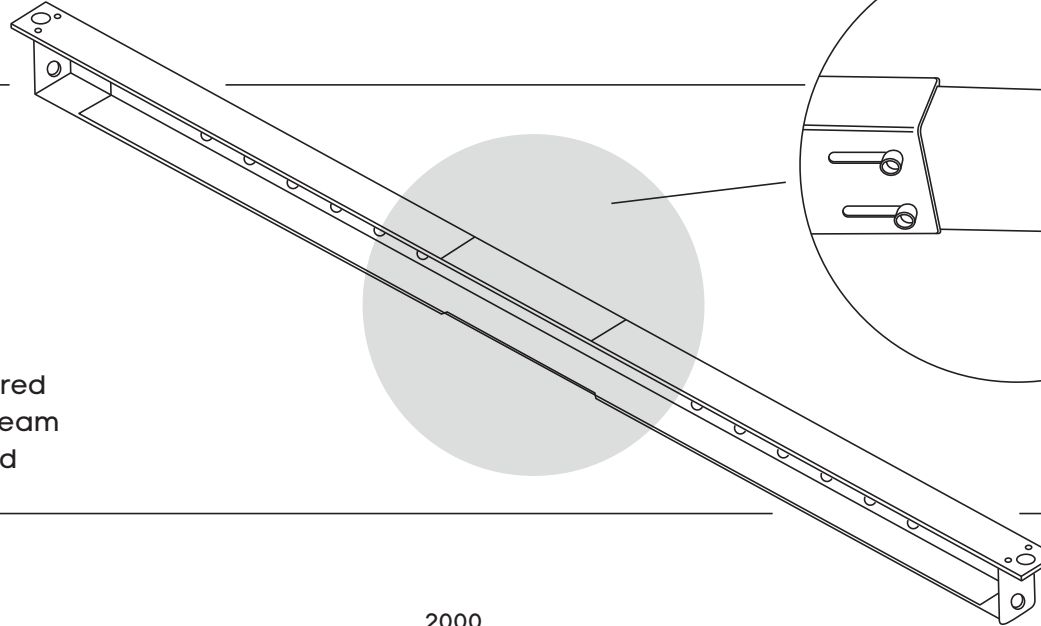

ASSEMBLY INSTRUCTIONS

Quadro Loop 2P workstation

Sizes: 1200, 1400, 1600, 1800 mm

www.jasonl.com.au

Need help!

Call us on
1300 527 665

jason.l
your office furniture mate

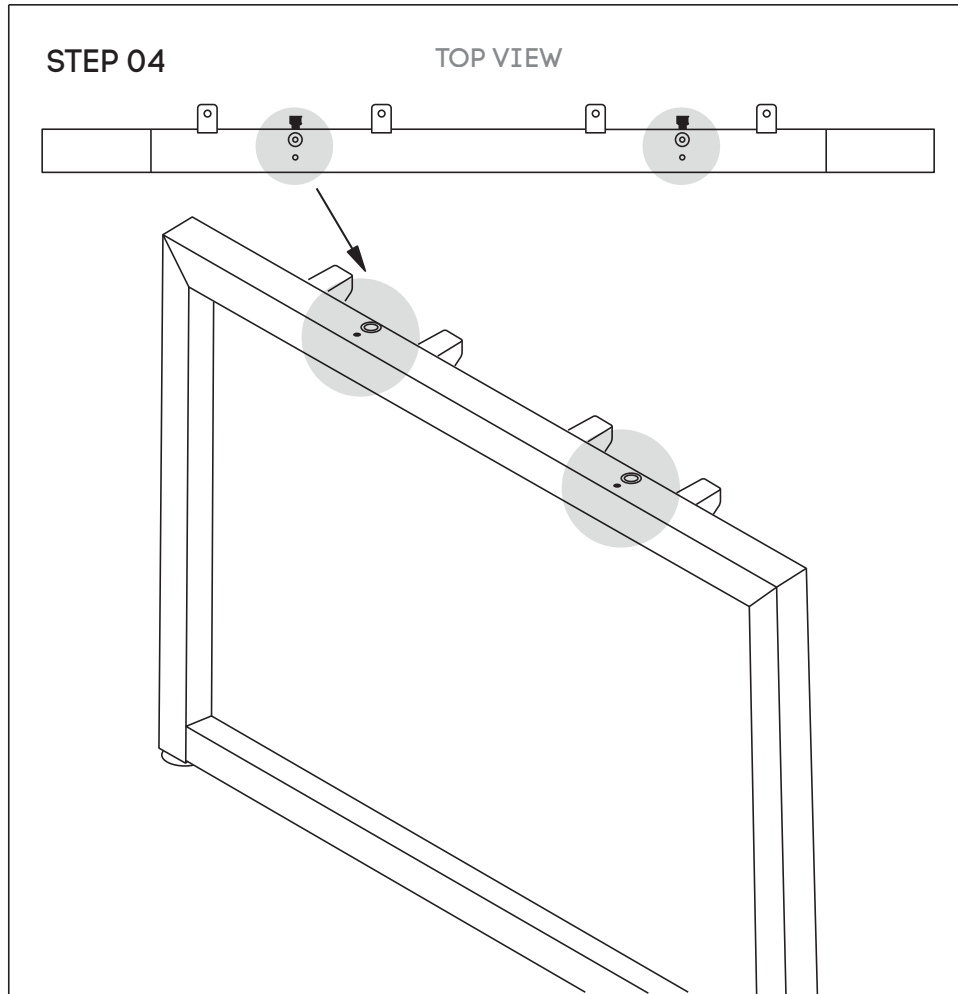

Attach beam **(D)** to legs **(B)** using nut insert in legs.
See point attached

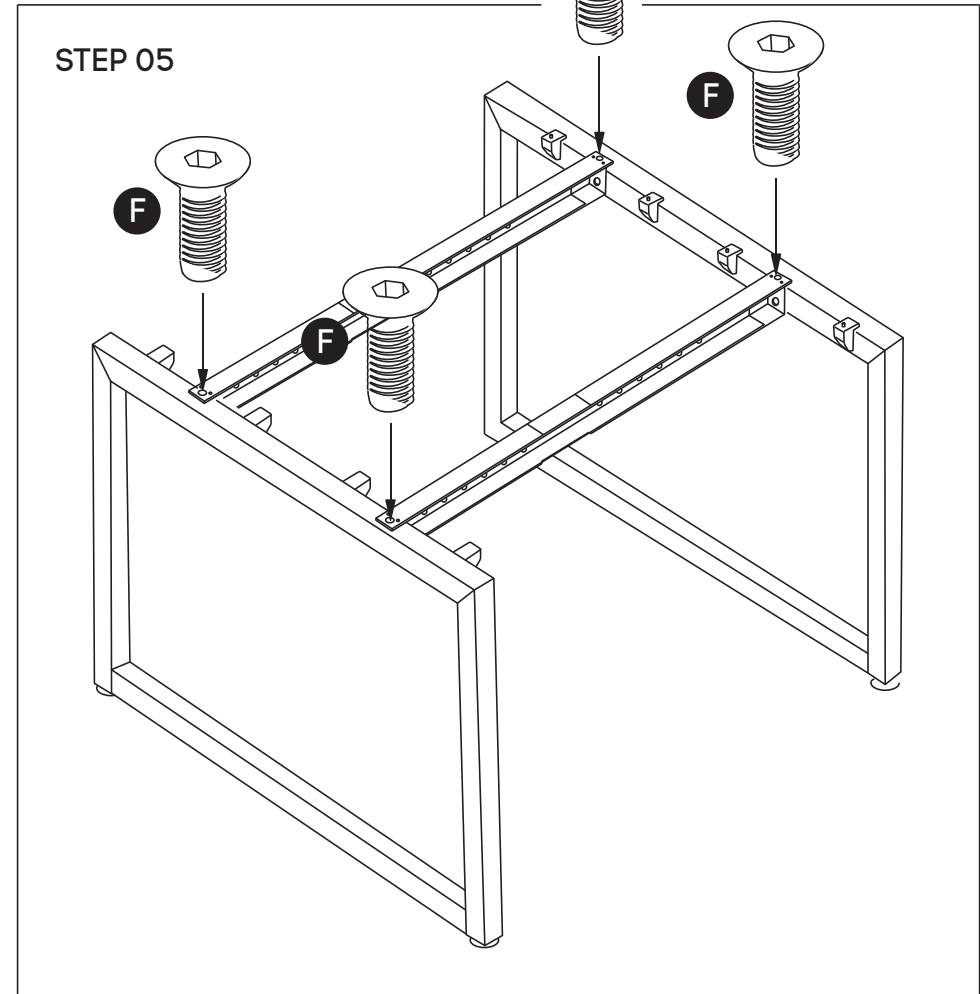

Frame looks like this. Using Allen Key, attach beam **(D)** with Socket **(F)**

ASSEMBLY INSTRUCTIONS

Quadro Loop 2P workstation

Sizes: 1200, 1400, 1600, 1800 mm

www.jasonl.com.au

Need help!

Call us on
1300 527 665

jason.l
your office furniture mate

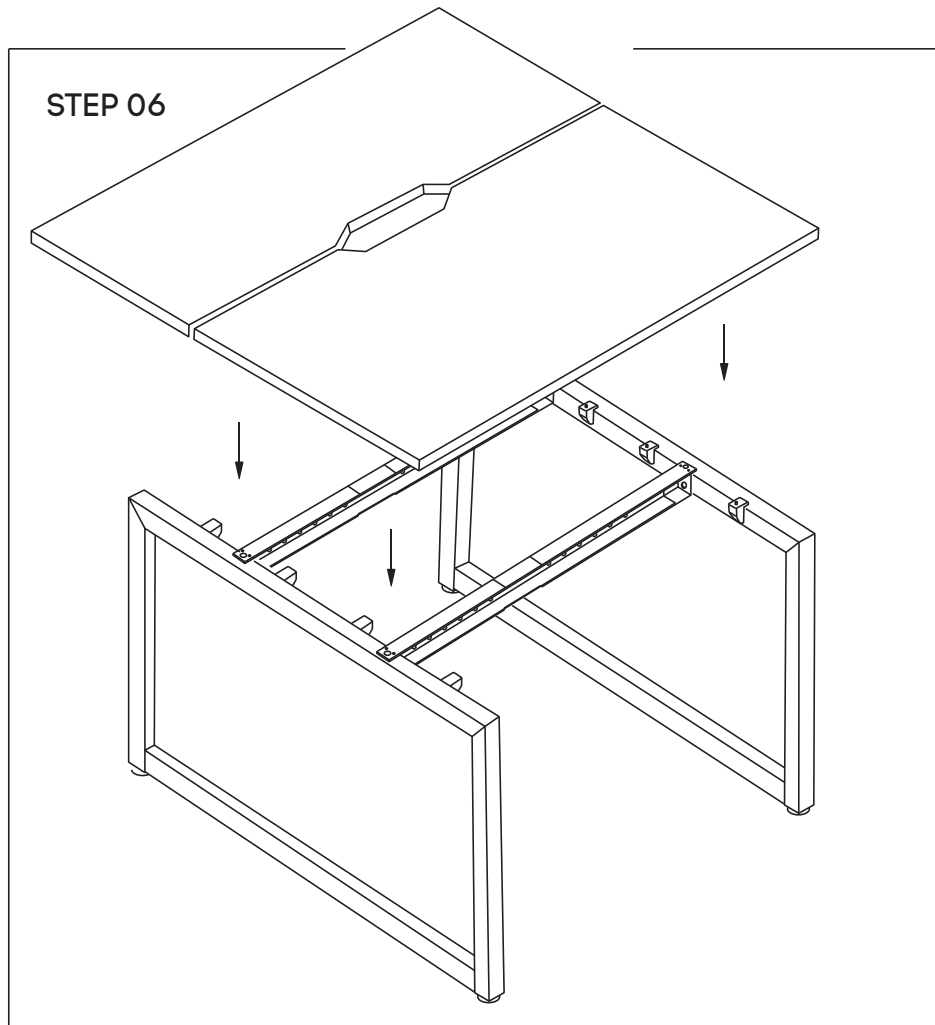

Place desktops ontop of frame - with cutout at the back of the desk. Nut inserts in top will align with plastic joiner brackets using M6x30MM **(I)** sockets attached tops to frame.

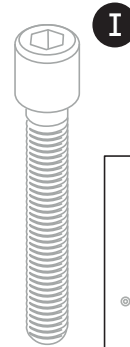

TABLE TOP
BOTTOM VIEW

