

**ASSEMBLY INSTRUCTIONS**  
**Quadro A leg 2 person**  
**corner workstations**  
**U configuration**

[www.jasonl.com.au](http://www.jasonl.com.au)

**Need help!**  
Call us on  
**1300 527 665**

**jason.l**  
your office furniture mate



Sizes: 1400Lx1800W , 1600Lx1800W , 1800Lx1800W mm

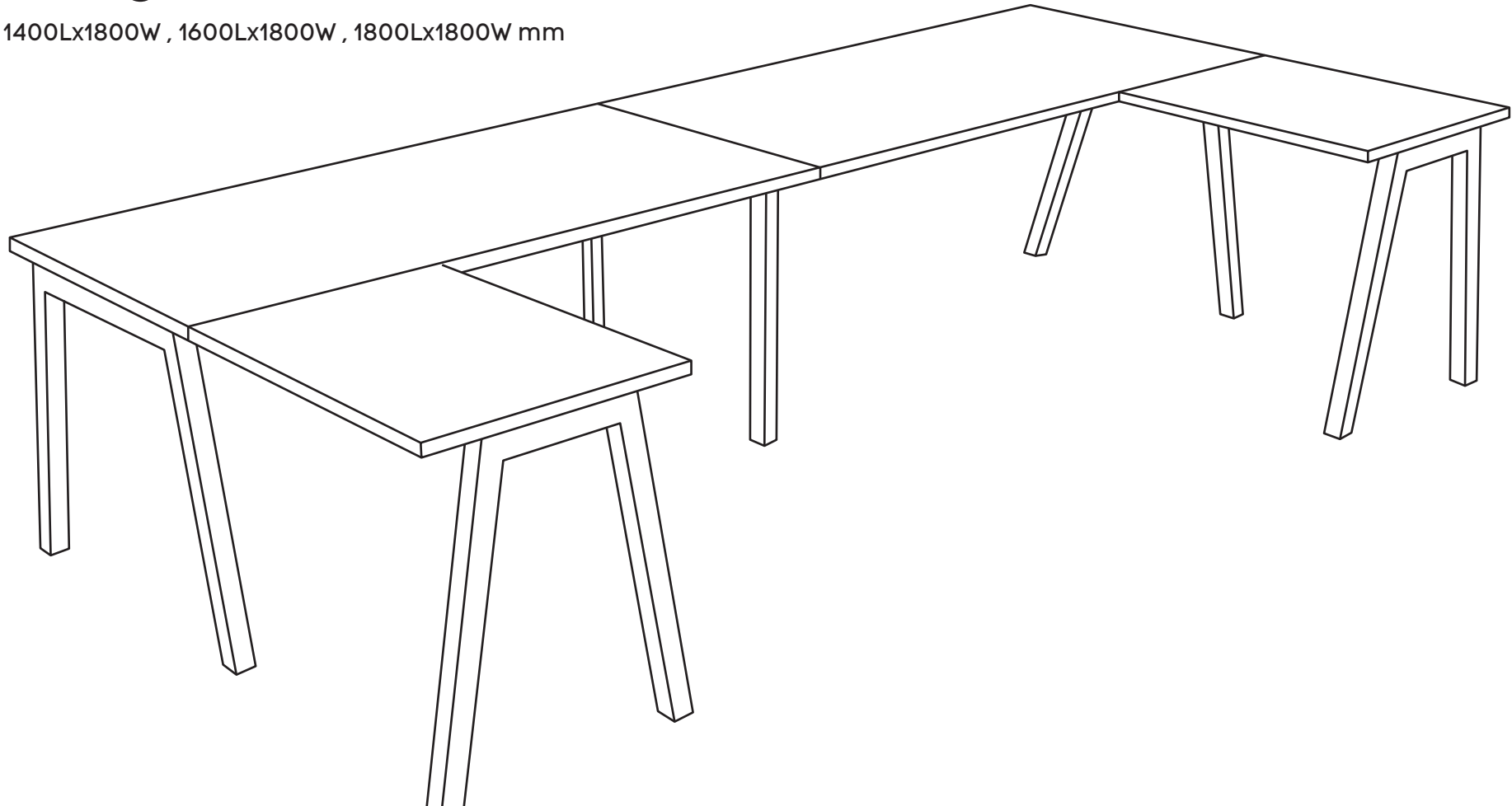

**Tools Required:** Power screwdriver; Allen key set (provided)

 2 persons required for installation

# ASSEMBLY INSTRUCTIONS

## Quadro A leg 2 person corner workstations U configuration

[www.jasonl.com.au](http://www.jasonl.com.au)

**Need help!**  
Call us on  
**1300 527 665**

**jason.l**  
your office furniture mate



Sizes: 1400Lx1800W , 1600Lx1800W , 1800Lx1800W mm

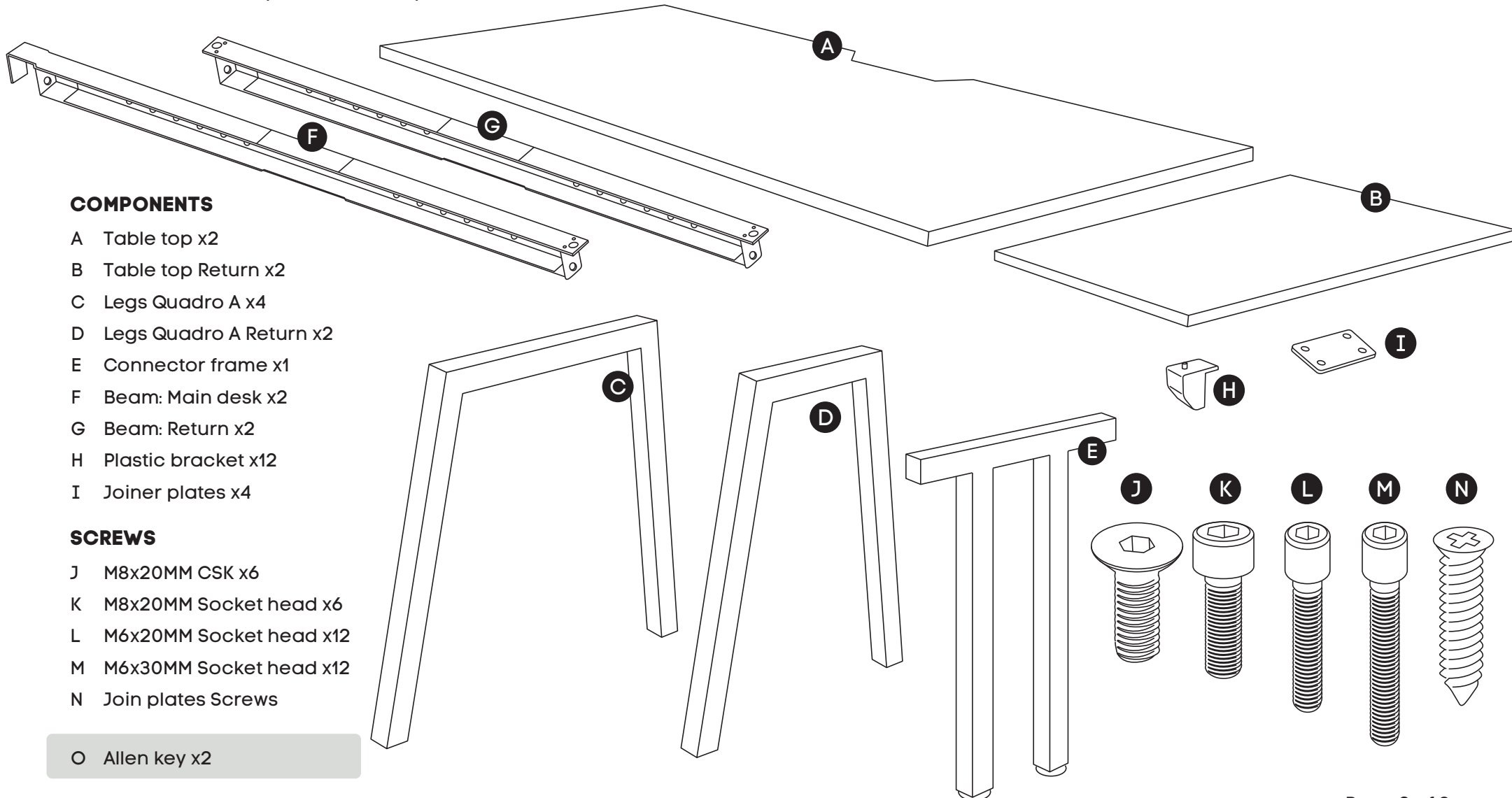

### COMPONENTS

- A Table top x2
- B Table top Return x2
- C Legs Quadro A x4
- D Legs Quadro A Return x2
- E Connector frame x1
- F Beam: Main desk x2
- G Beam: Return x2
- H Plastic bracket x12
- I Joiner plates x4

### SCREWS

- J M8x20MM CSK x6
- K M8x20MM Socket head x6
- L M6x20MM Socket head x12
- M M6x30MM Socket head x12
- N Join plates Screws

O Allen key x2

# ASSEMBLY INSTRUCTIONS

## Quadro A leg 2 person corner workstations

### U configuration

[www.jasonl.com.au](http://www.jasonl.com.au)

**Need help!**

Call us on  
**1300 527 665**

**jason.l**  
your office furniture mate



Sizes: 1400Lx1800W , 1600Lx1800W , 1800Lx1800W mm

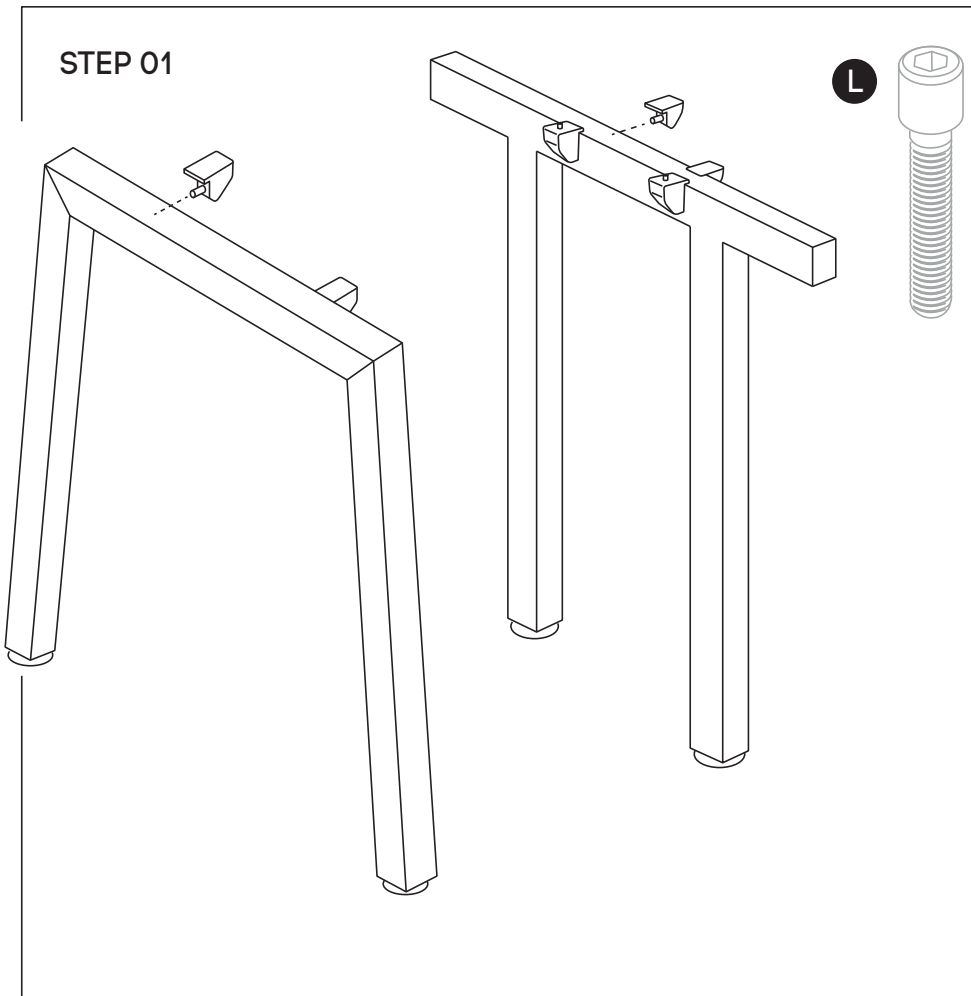

Using Allen Key provided, attach 2 plastic brackets per leg **(C)(D)** (as per picture above) using M6x20MM **(L)** Socket head screw. Do the same with Connector frame **(E)**.



Using Allen Key provided, attach M8x20MM Socket head **(K)**-screw socket half way into leg for both legs **(C)** and into Connector frame **(E)**.

# ASSEMBLY INSTRUCTIONS

## Quadro A leg 2 person corner workstations

### U configuration

[www.jasonl.com.au](http://www.jasonl.com.au)

**Need help!**  
Call us on  
**1300 527 665**

**jason.l**  
your office furniture mate



Sizes: 1400Lx1800W , 1600Lx1800W , 1800Lx1800W mm

#### STEP 03

Adjust extendable beam **(F)** to desired length using markers and secure beam at that length using screws provided

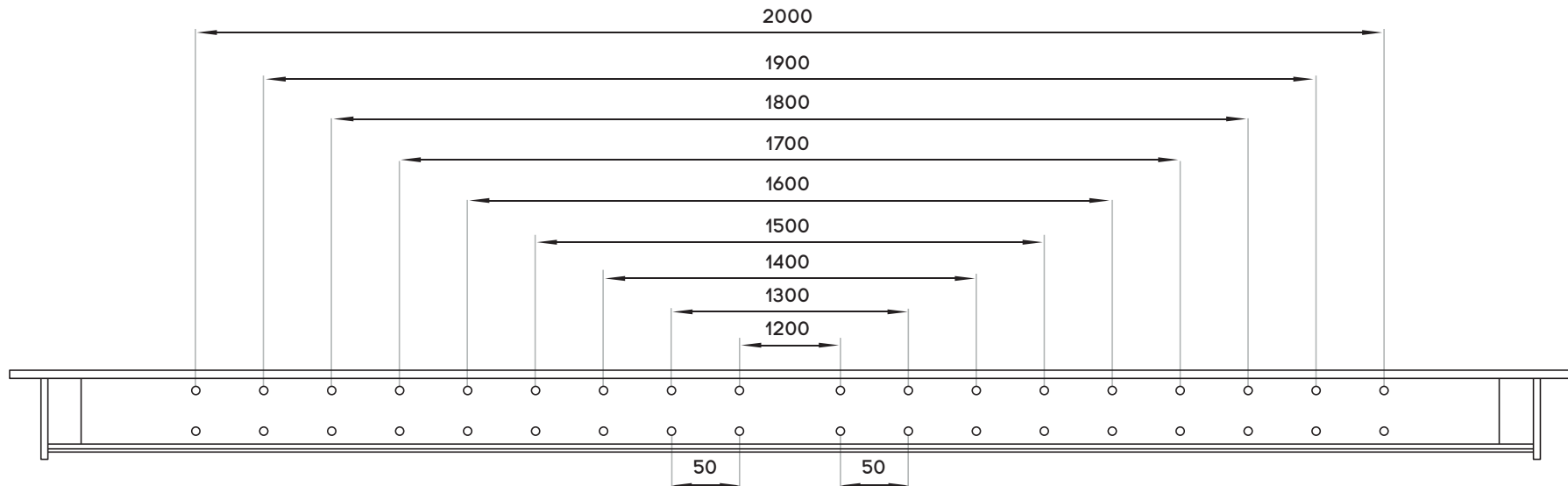
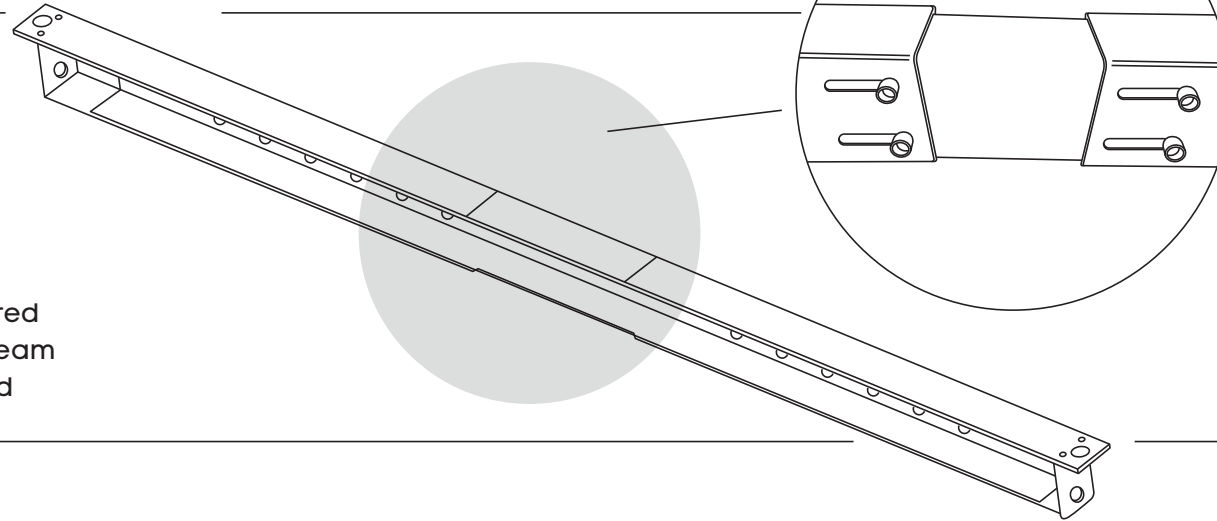

# ASSEMBLY INSTRUCTIONS

## Quadro A leg 2 person corner workstations

### U configuration

[www.jasonl.com.au](http://www.jasonl.com.au)

**Need help!**

Call us on  
**1300 527 665**

**jason.l**  
your office furniture mate



Sizes: 1400Lx1800W , 1600Lx1800W , 1800Lx1800W mm

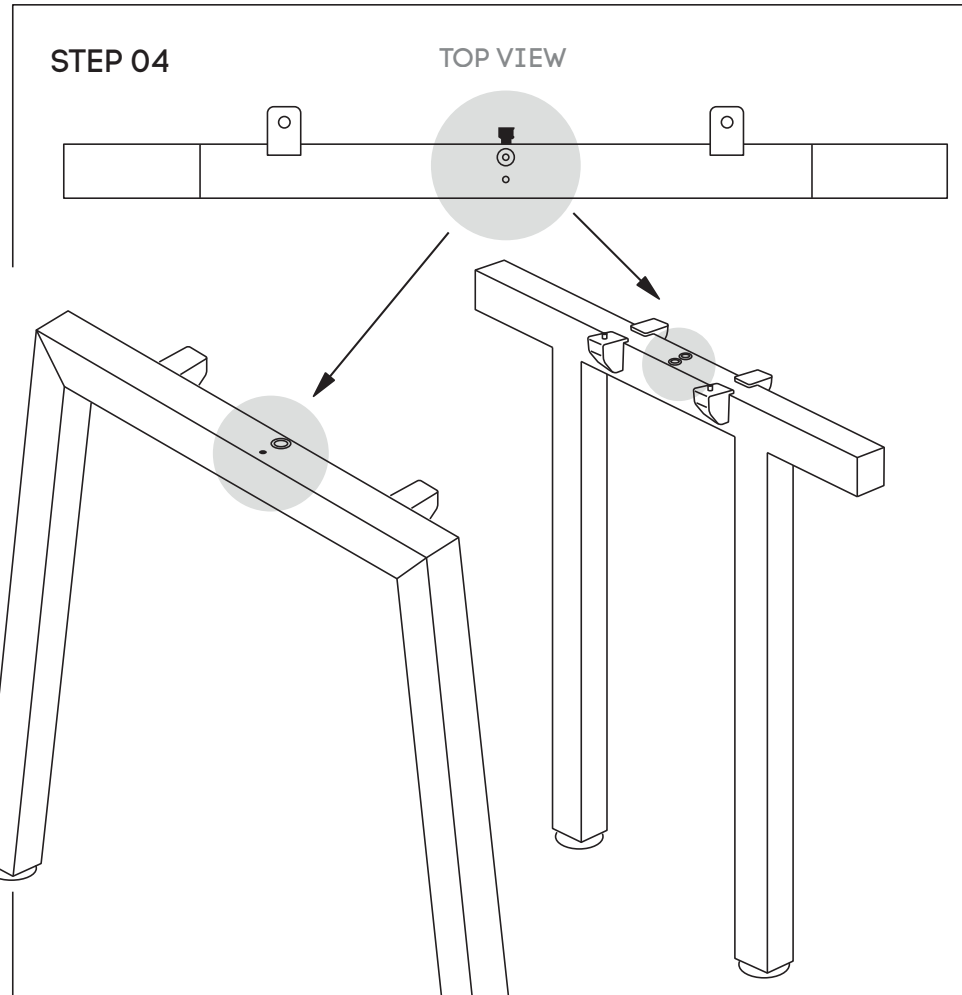

Attach beam **(F)** to legs **(C)** and Connector frame **(E)** using nut insert in legs. See point attached

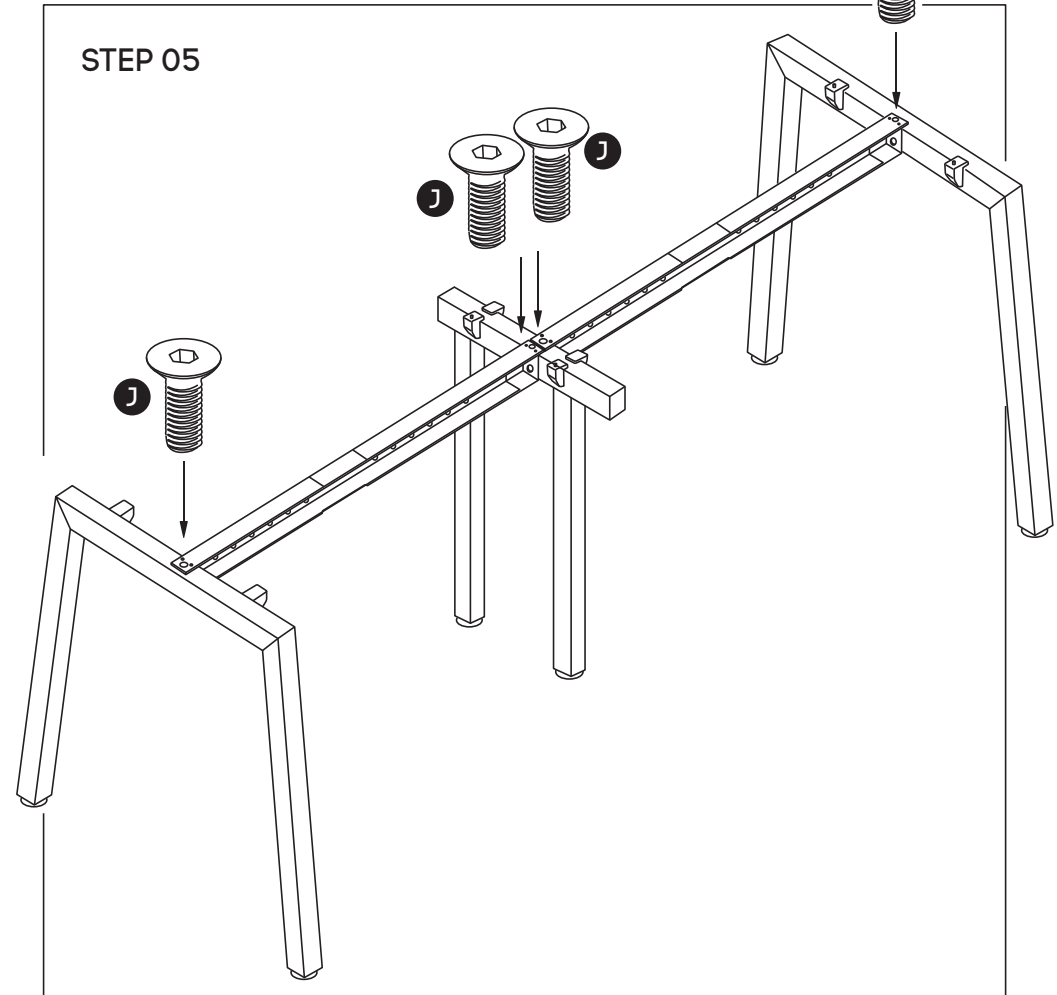

Frame looks like this. Using Allen Key, attach beam **(F)** with Socket **(J)**

# ASSEMBLY INSTRUCTIONS

## Quadro A leg 2 person corner workstations

### U configuration

Sizes: 1400Lx1800W , 1600Lx1800W , 1800Lx1800W mm

[www.jasonl.com.au](http://www.jasonl.com.au)

**Need help!**  
Call us on  
**1300 527 665**

**jason.l**  
your office furniture mate

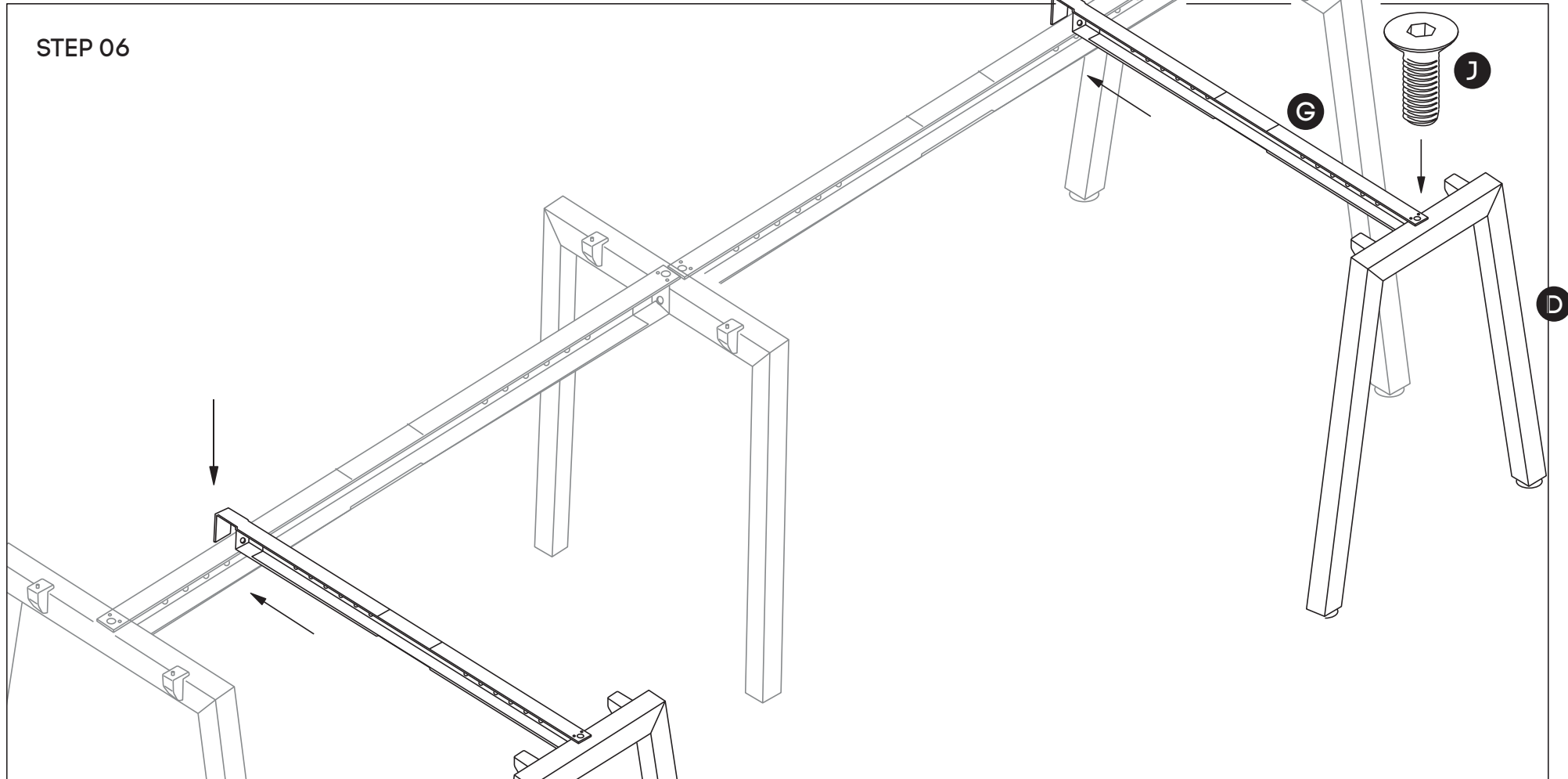

Now attach the return beams (**G**) to return legs (**D**) using nut insert in legs. See point attached.  
Then, connect the hook of the return beam to the beam of the main structure.

# ASSEMBLY INSTRUCTIONS

## Quadro A leg 2 person corner workstations U configuration

[www.jasonl.com.au](http://www.jasonl.com.au)

**Need help!**  
Call us on  
**1300 527 665**

**jason.l**  
your office furniture mate



Sizes: 1400Lx1800W , 1600Lx1800W , 1800Lx1800W mm

STEP 07

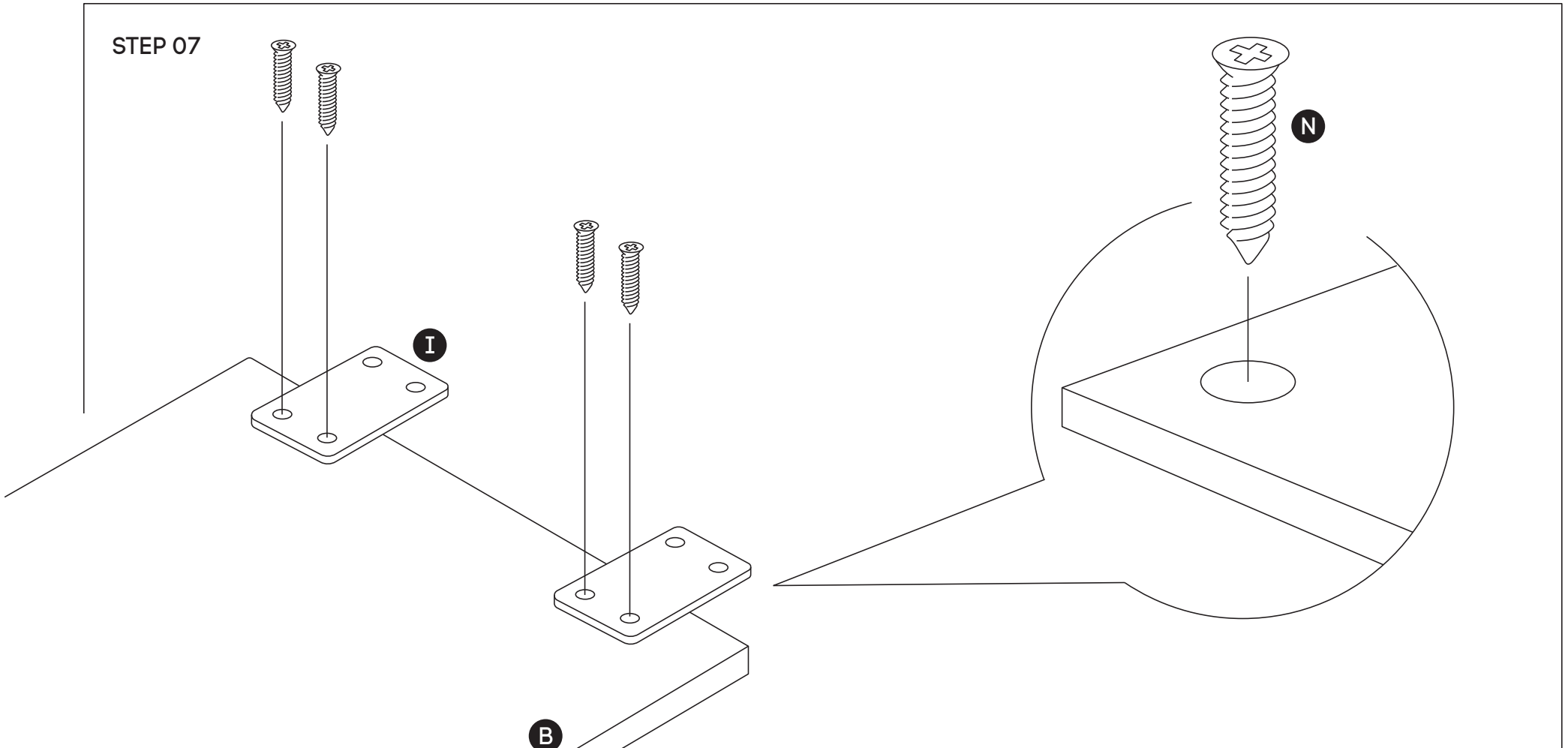

Attach Connector Plates (I) to Return Top (B) by tightening Screws (N)

# ASSEMBLY INSTRUCTIONS

## Quadro A leg 2 person corner workstations

### U configuration

[www.jasonl.com.au](http://www.jasonl.com.au)

**Need help!**  
Call us on  
**1300 527 665**

**jason.l**  
your office furniture mate



Sizes: 1400Lx1800W , 1600Lx1800W , 1800Lx1800W mm

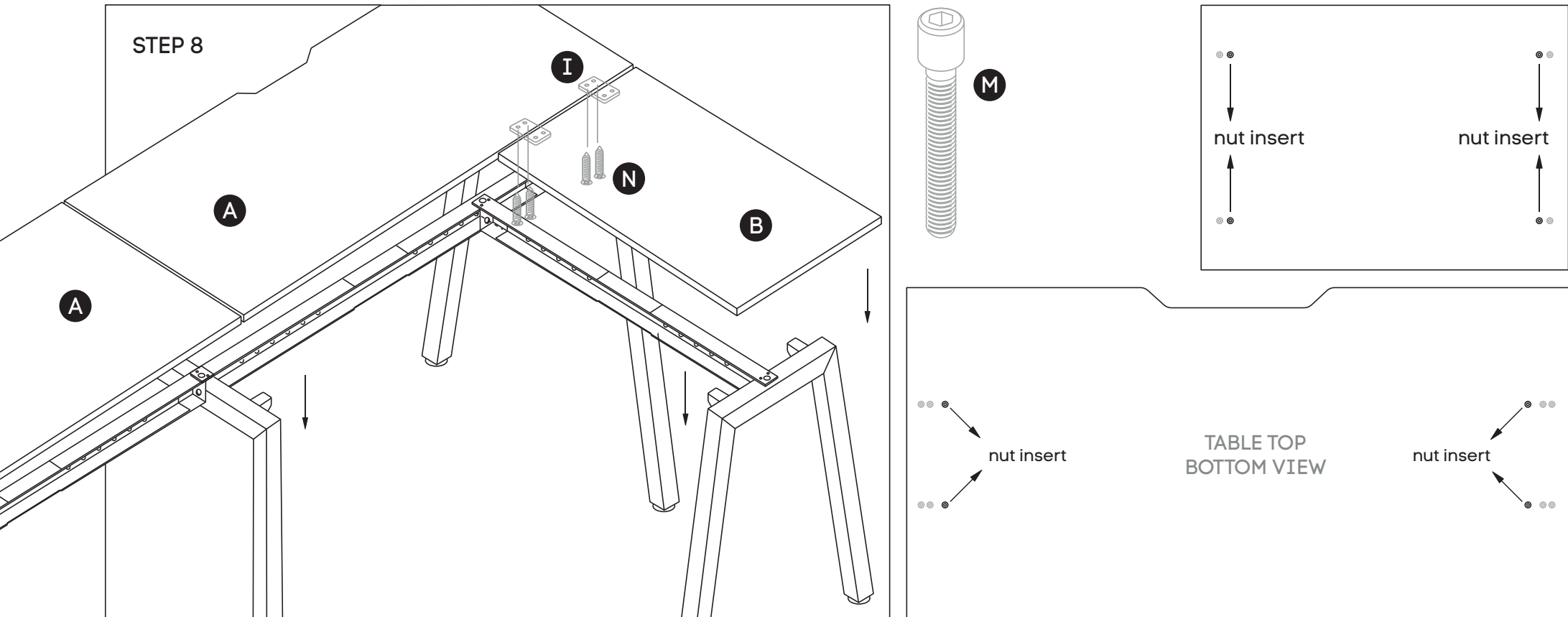

- Place table tops **(A)** on top of frame - with cutout at the back of the desk.
- Using nut inserts in the desktop, use M6x30mm socket **(M)** and attach desktop to the frame.
- Using nut inserts in the desktop, use M6x30mm socket **(M)** and attach return desktops **(B)** to the frame.
- Once desktop are attached and secure to the frame, use woods screws **(N)** and secure joiner plates **(I)** to the underside of desktop A.



# ASSEMBLY INSTRUCTIONS

## Quadro A leg 2 person corner workstations U configuration

[www.jasonl.com.au](http://www.jasonl.com.au)

**Need help!**

Call us on  
**1300 527 665**

**jason.l**  
your office furniture mate



Sizes: 1400Lx1800W , 1600Lx1800W , 1800Lx1800W mm

STEP 9

**If you  
purchased with  
screens divider**

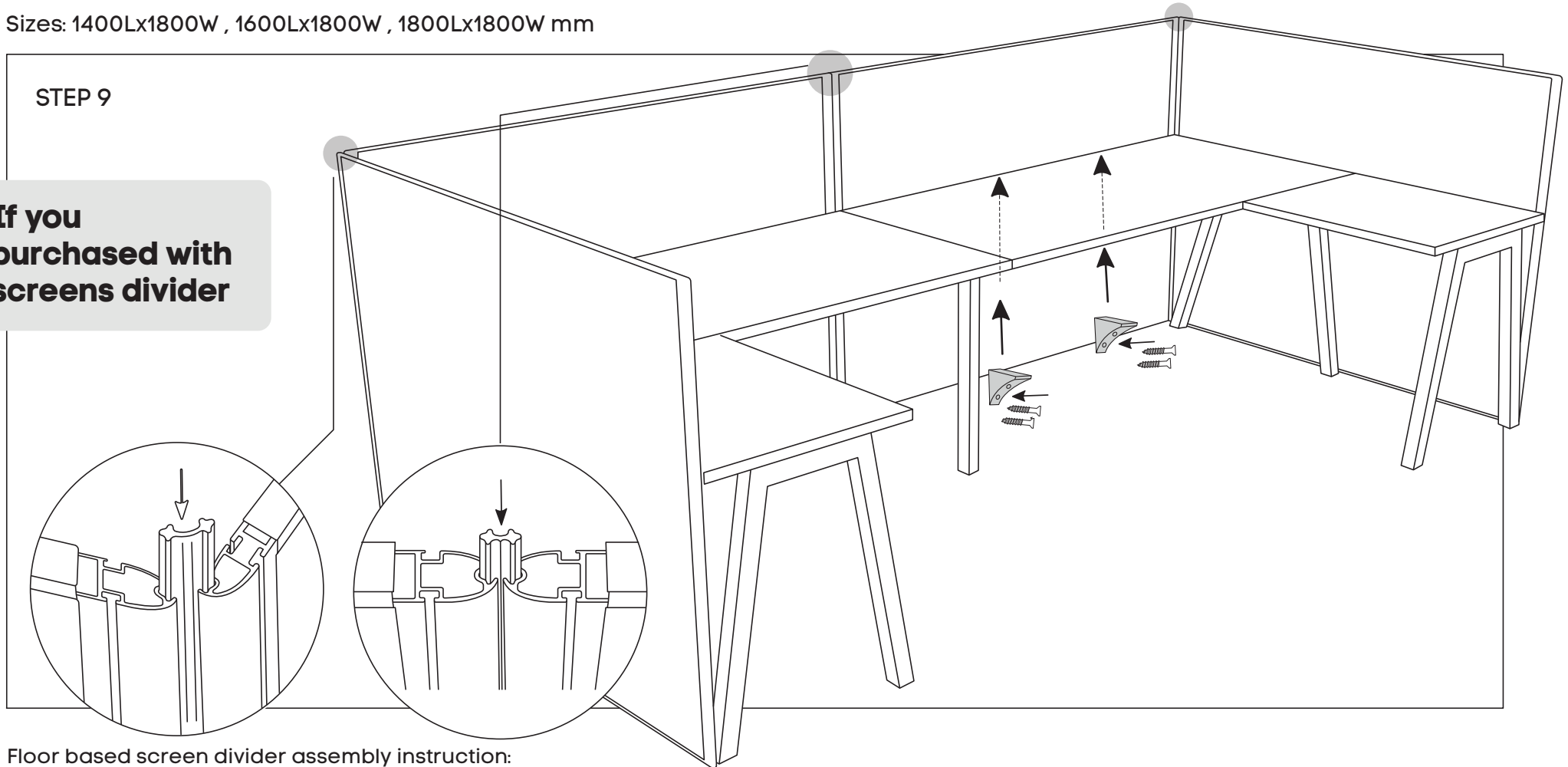

Floor based screen divider assembly instruction:

- Bring partition towards one another as on the picture. Using an Allen key remove top caps from the four screens uprights where they meet (circles painted in gray).
- Slide 2 way connectors rod - down between the 2 centre screens and slide the 2 way 90 degree connector rod -down between the end screens.
- Under the desktops, use L-shaped panel brackets to secure the screens to the table tops **(A)(B)**. Place two brackets in each screen.