

ASSEMBLY INSTRUCTIONS

# Just Right 4P Workstation H-Bench

1200x700 | 1400x700 | 1600x700

[www.jasonl.com.au](http://www.jasonl.com.au)

**Need help!**

Call us on  
**1300 527 665**

**jason.l**  
your office furniture mate

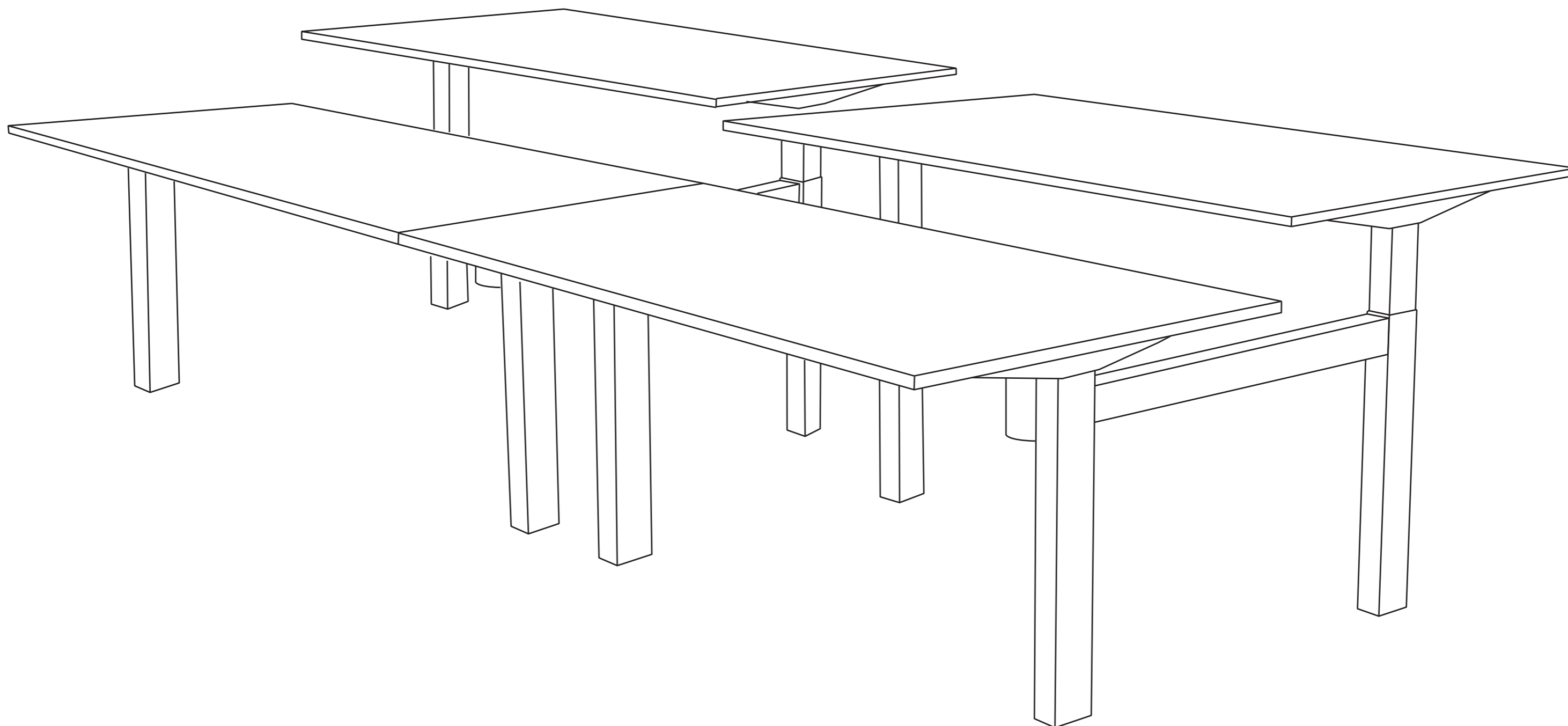

**Tools Required:** Power screwdriver

 2 persons required for installation

ASSEMBLY INSTRUCTIONS

# Just Right 4P Workstation H-Bench

1200x700 | 1400x700 | 1600x700

[www.jasonl.com.au](http://www.jasonl.com.au)

**Need help!**

Call us on  
**1300 527 665**

**jason.l**  
your office furniture mate



The first step is to assemble the workstations individually. The following steps contain in detail the parts and processes to follow, for each of them.

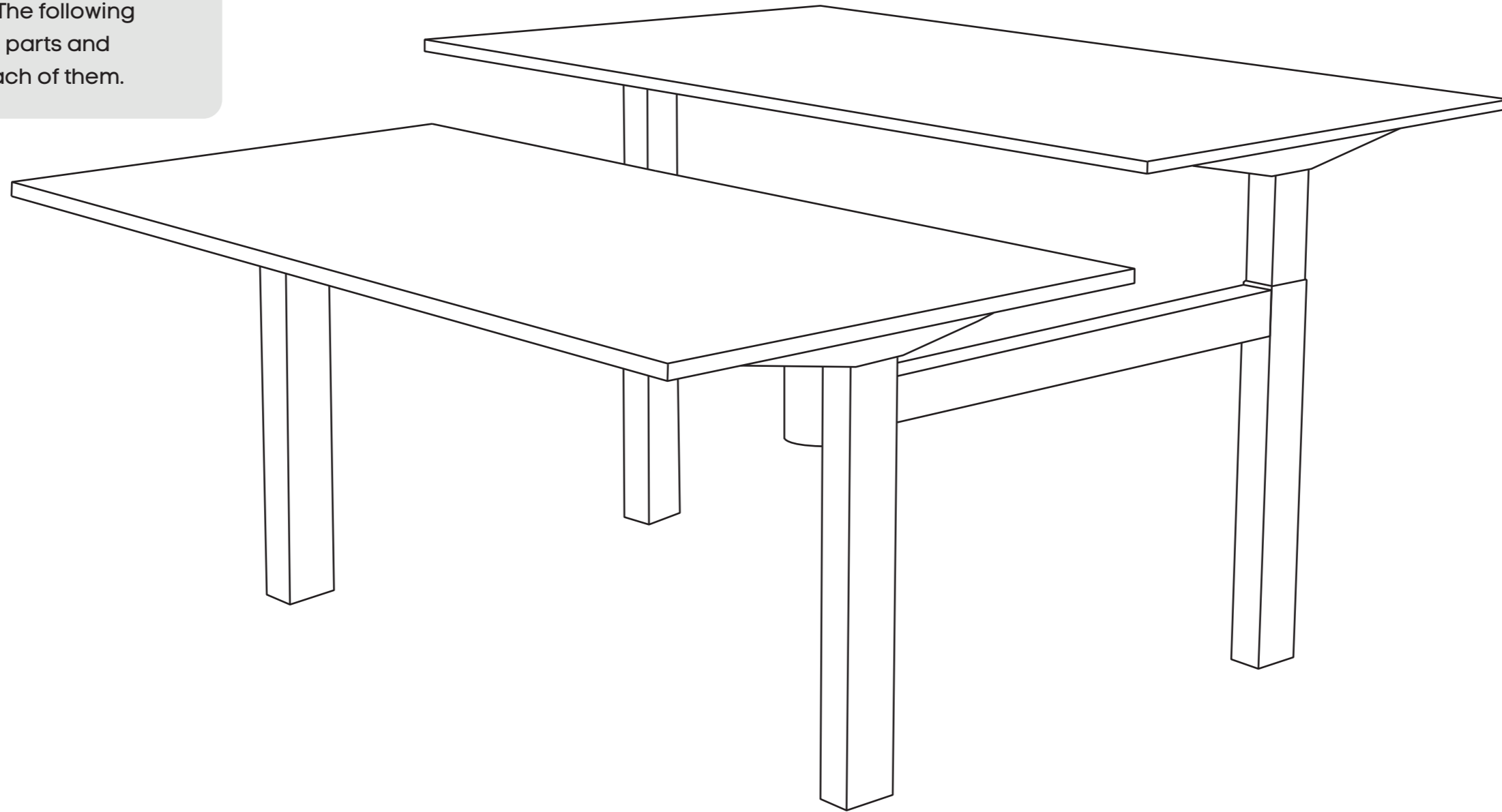

**Tools Required:** Power screwdriver

 2 persons required for installation

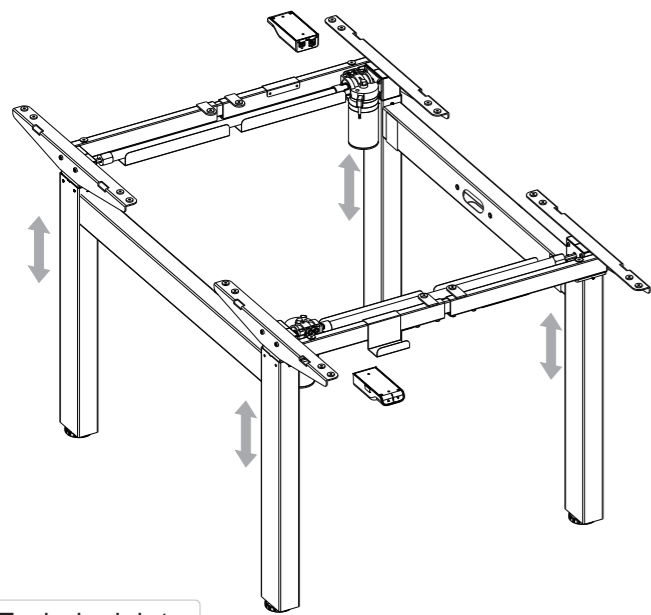

### Technical data

Column QTY	2	Input Voltage	100-240V
Max Loading Capacity	70kg	Max Speed	25mm/s
Height Range	690-1190mm	Temperature	0- 40°C
Length Range	850-1290mm		
Frequency	10%(Continuous operation for 2 mins at most after pause for 18 mins)		

### Accessory list

Attention: The drawings below are only for reference which might be slightly different from the actual object, please in kind prevail. Any tools missing or installation problems, please contact the customer service firstly.

No.	Image	Spec	Qty
A		Allen key 2.5x2.5mm   Allen key 4x4mm   Allen key 5x5mm	1
B		ST4.2	20
C		M4	8
D		M8	8
E		M8	8
F		M6	8
G		Wrench	1

### Packing List

- Right Lifting Column x2
- Left Lifting Column x2
- Connecting Beam x2
- Cover x4
- Supporting Beam x2
- Supporting Plate x4
- Transmission Rod x2
- Baffle x4
- Adapter x2
- Handset x2
- Power Cable x2
- Adapter Hook x2
- Ratchet Wrench
- Switch Line x2
- Cable Tie x8
- ST4.2X19 Screws x4 (packaged in 2 packs)

### Installation instruction

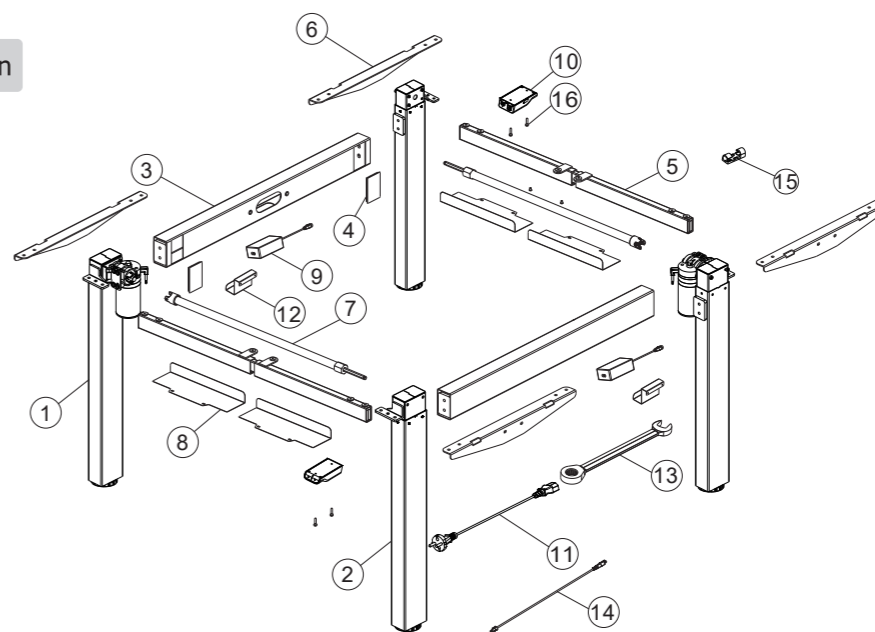

#### STEP1

Install Connecting Beam

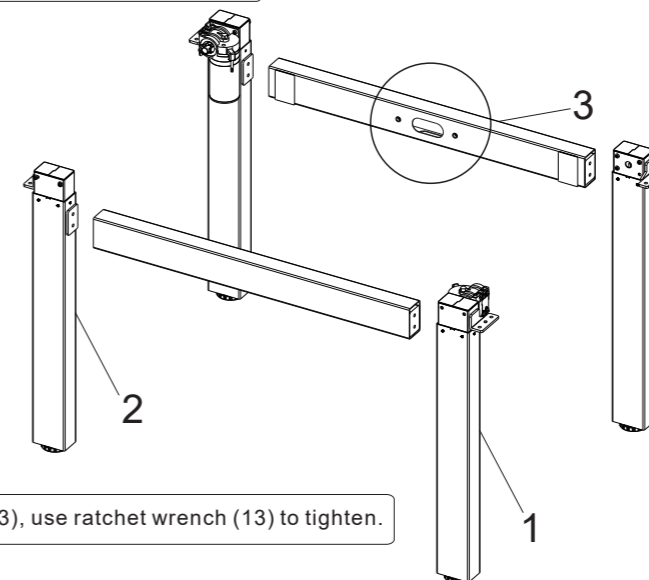

Install connecting beam(3), use ratchet wrench (13) to tighten.

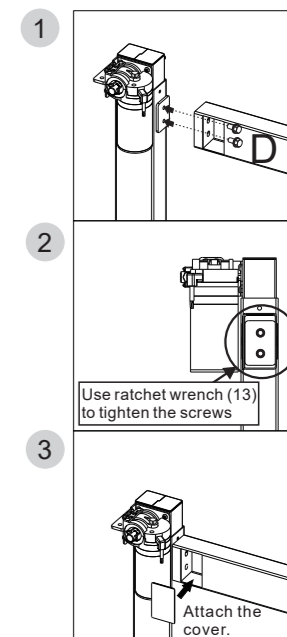

#### STEP2

Install Supporting Beam

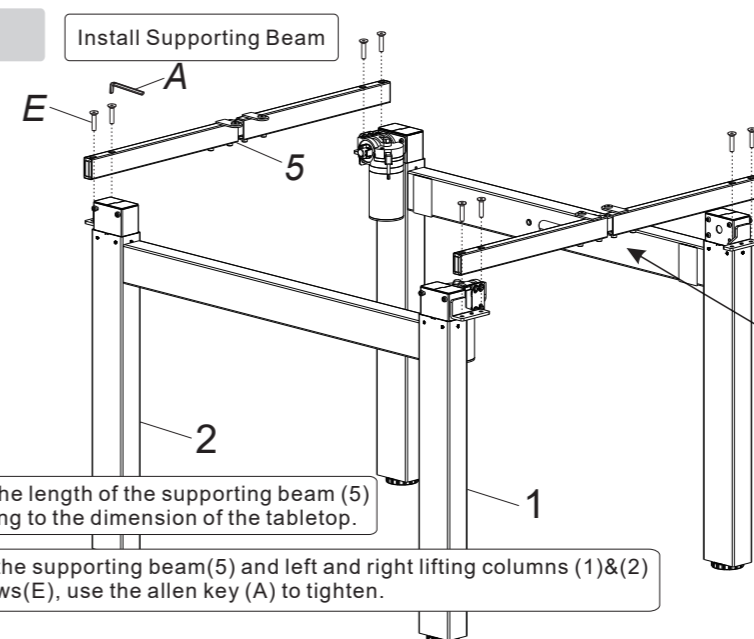

Adjust the length of the supporting beam (5) according to the dimension of the tabletop.

Connect the supporting beam(5) and left and right lifting columns (1)&(2) with screws(E), use the allen key (A) to tighten.

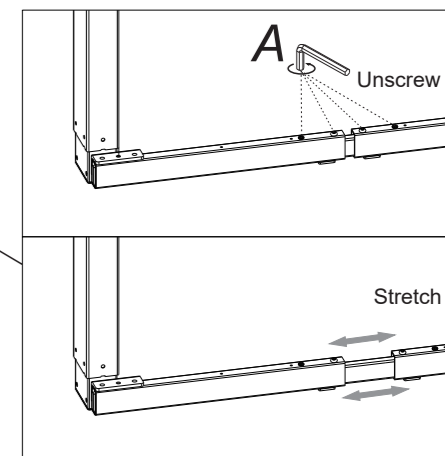

**STEP3**

## Install Transmission Rod

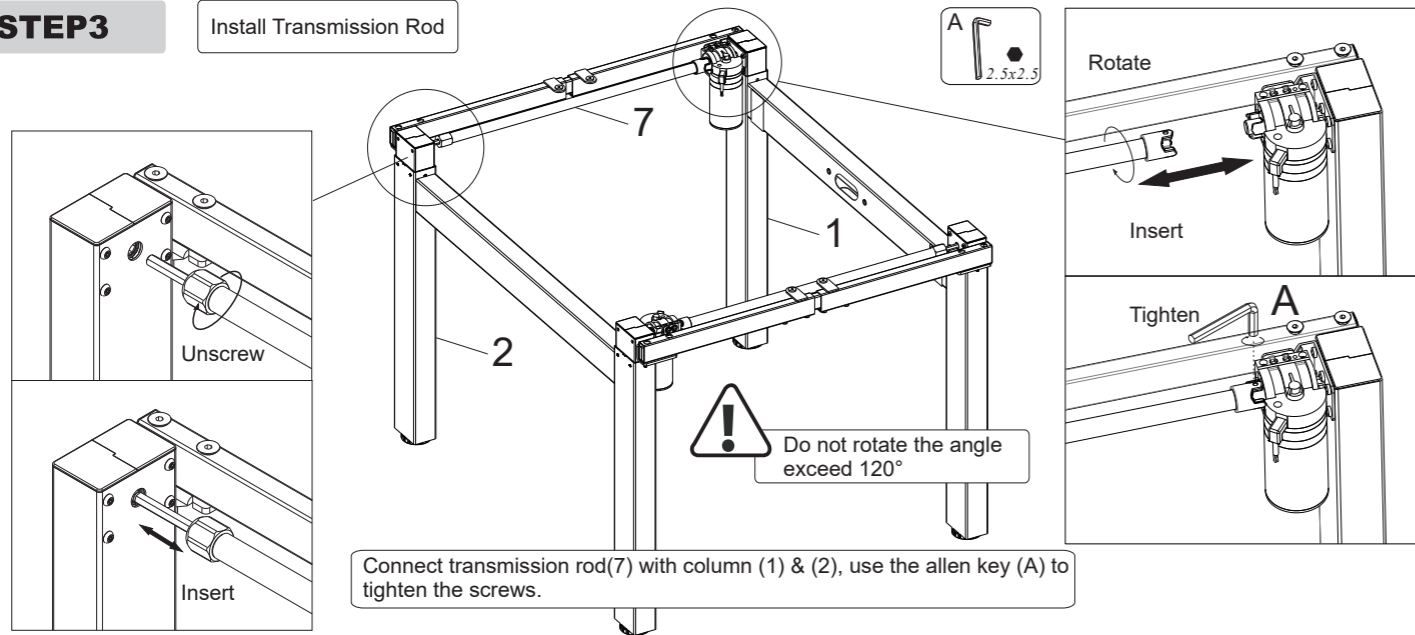
**STEP6**

## Install Tabletop and Handle

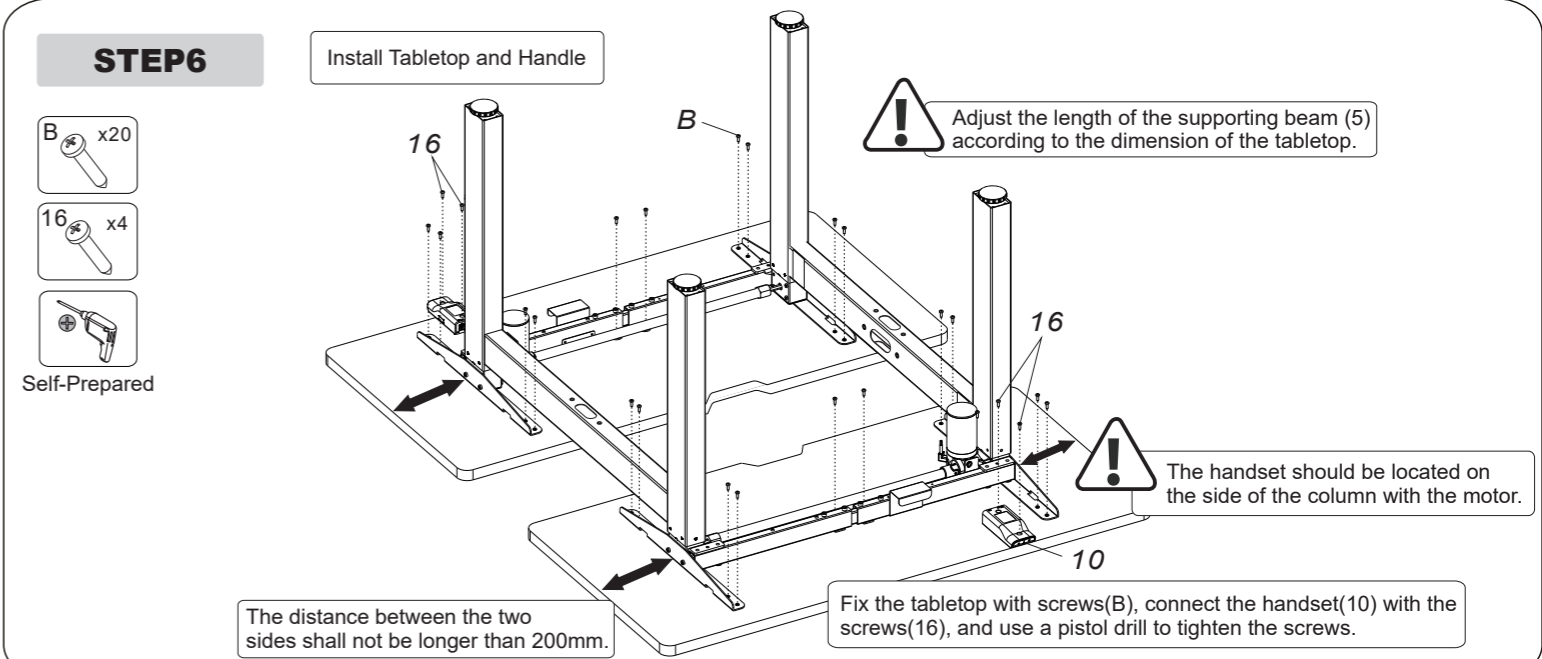
**STEP4**

## Install Supporting Plate

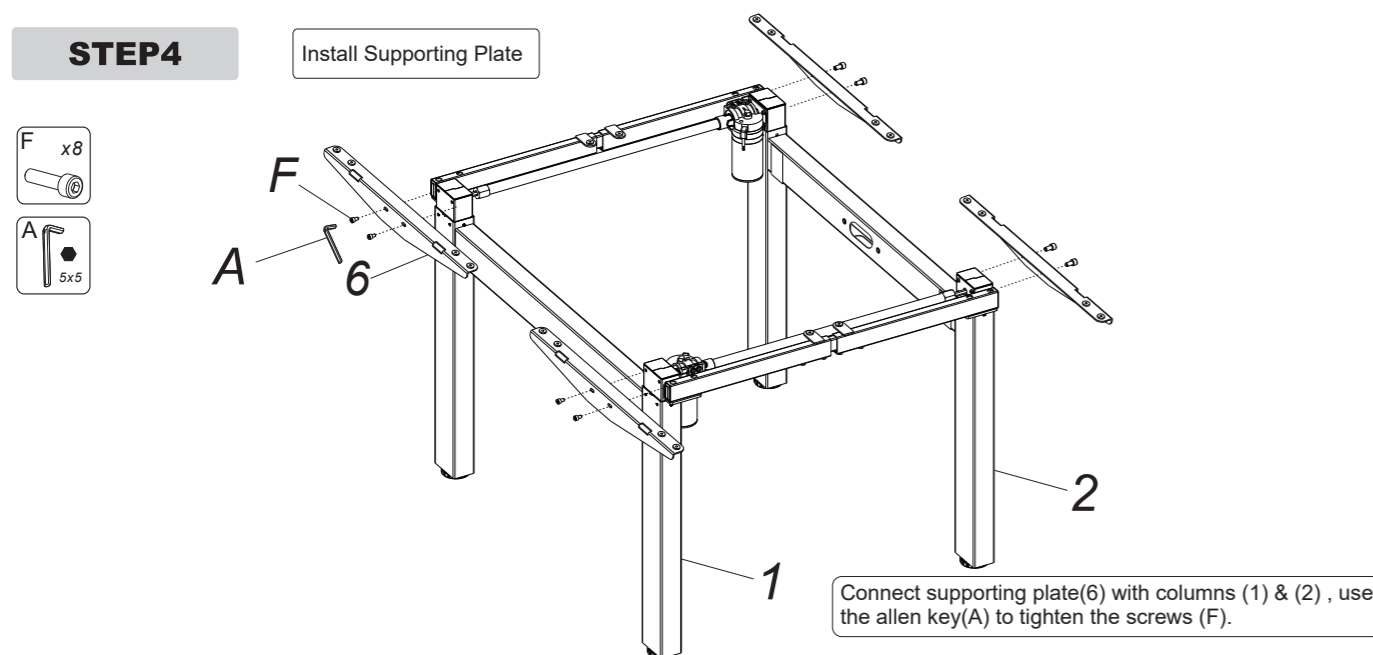
**STEP7**

## Tighten the Screws on Beams and Nuts on Transmission Rod

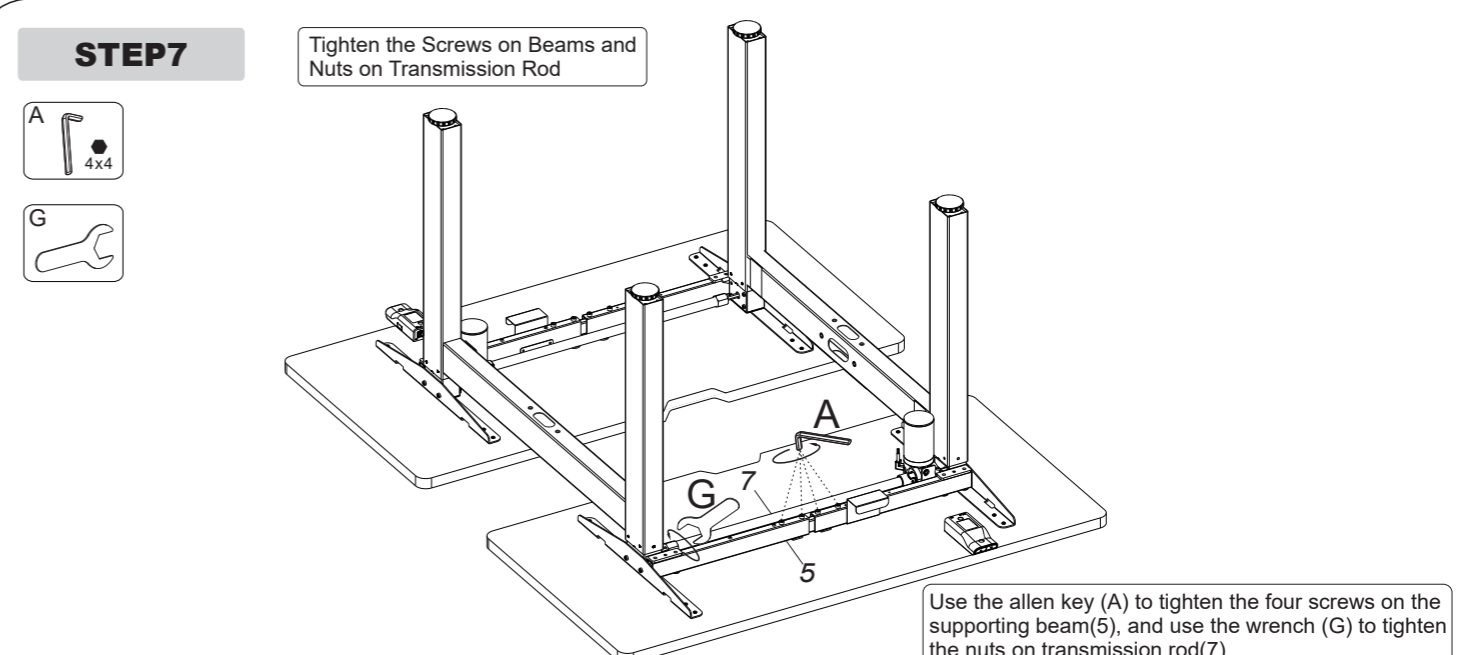
**STEP5**

## Install Adapter Hook

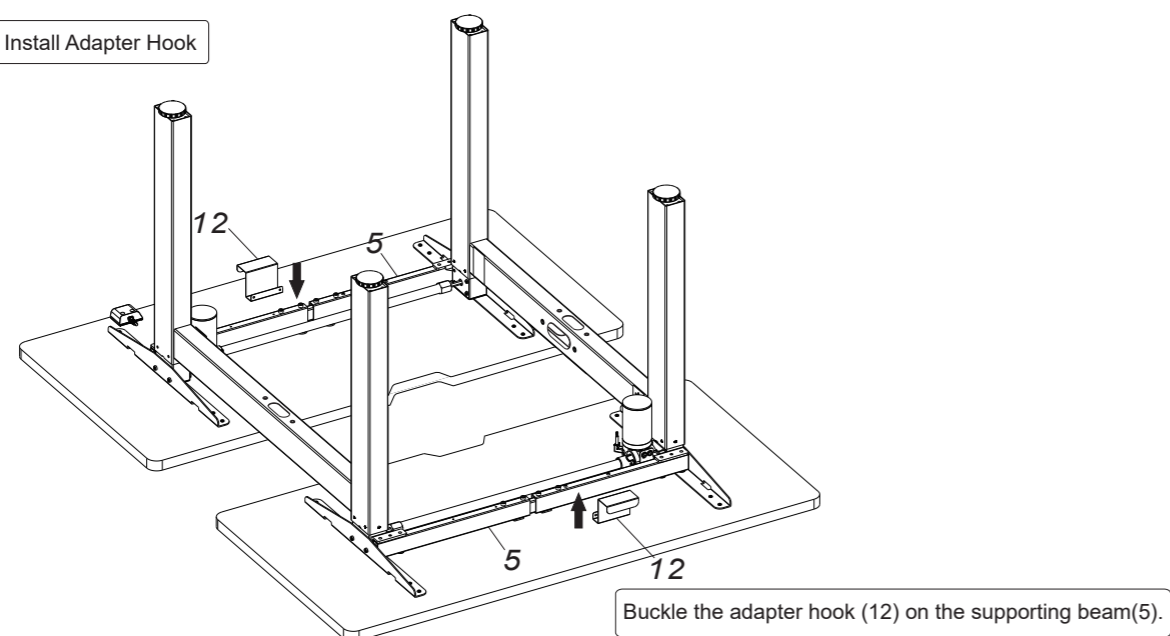
**STEP8**

## Install Baffle and Adapter

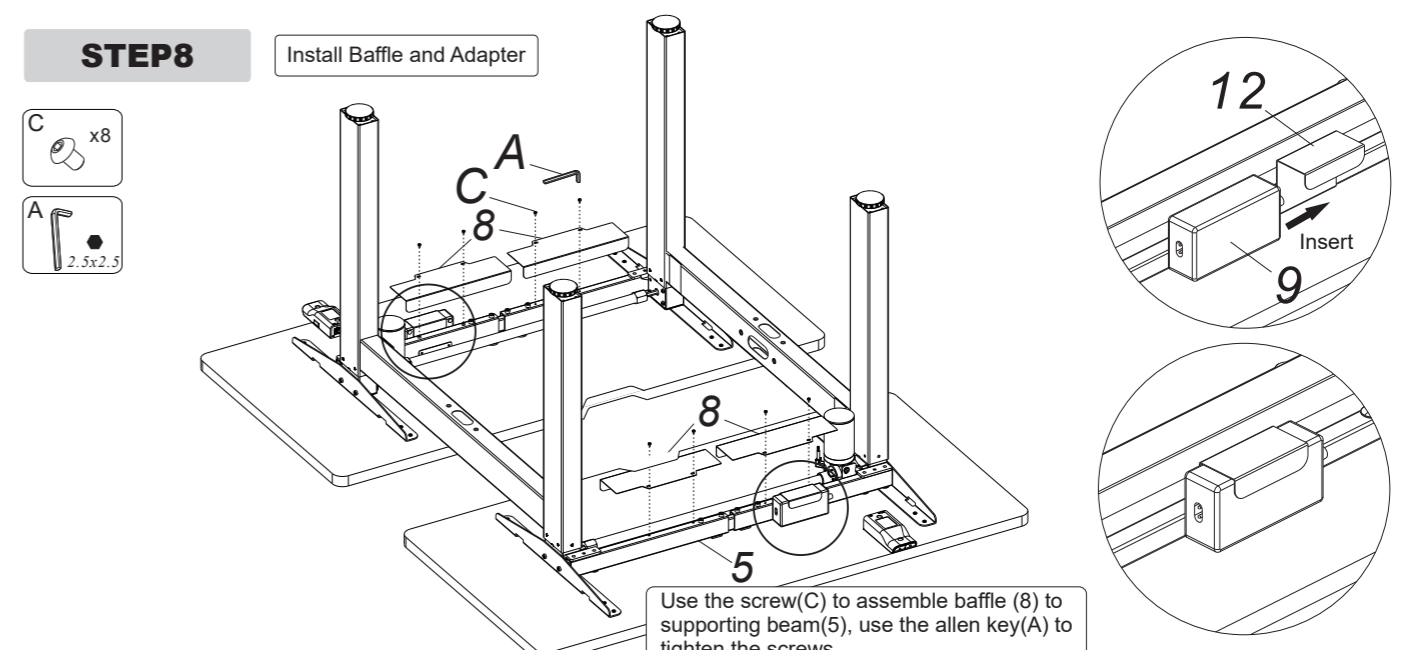

## STEP 9

Connect all Wires to the Adapter

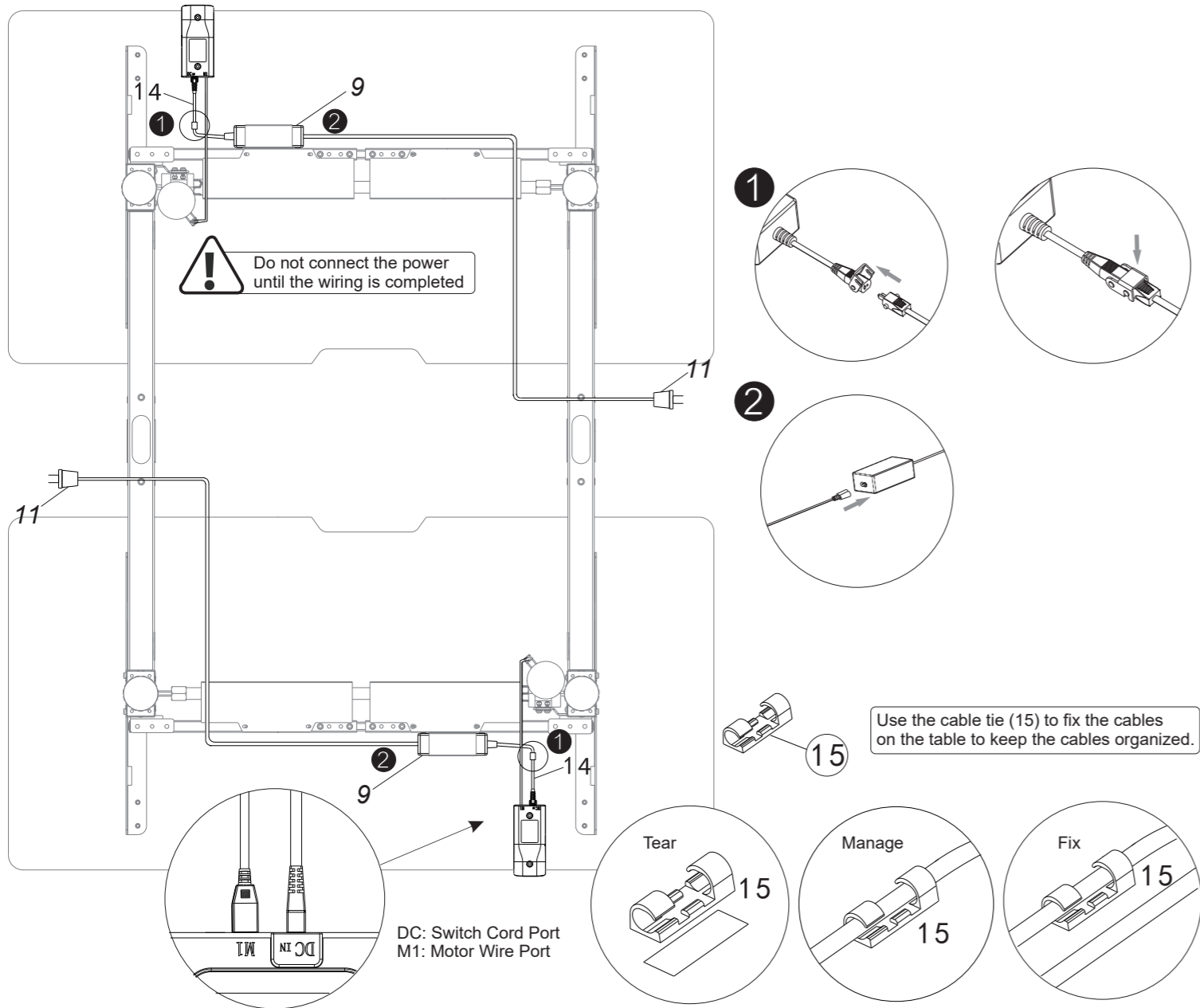

## Common fault treatment

The following tips will help you detected and eliminate the common fault and error. If the fault you met is not listed below, please contact with your supplier. Only the manufacturer and professionals are capable for investigating and correcting those fault and error.

Fault phenomenon	Method
The desktop could not function	Check if all the cables well connected;
Rising in a low speed	Check if overloaded, max loading: 70kg;
The desk moving downwards without any operation	
Automatically Self-Reset	Reset;
Go down but not go up or go up but not go down	
The upper and downward height is not enough	
The desk could not lifted	Restart after suspend for 18mins while connecting with power.
Overwork (Duty cycle: Max 2min on/18min OFF)	



## Attention

1. Power supply: AC100V- 240V,50/60Hz
2. Service Environment: 0-40℃
3. Unplug the power plug before cleaning, wipe the dust on surface with slight wet dishcloth when cleaning, be careful not to let the drops into the internal parts, not loose the connector.
4. The electric box contains electronic components, metals, plastics, wires etc., so dispose of it in accordance with each country's environmental legislation, not the general household waste.
5. Check carefully to ensure correct and complete assembly before using.
6. Be familiar with all functions and program settings of the product before first use.
7. Children are forbidden to play on the product because of unforeseen action when playing, so any dangerous consequences caused by this improper action will not be on manufacturers.
8. Slight noise caused by the V-ribbed belt or brake system due to structure will not have any effect on the use of the equipment.
9. Corrosive or abrasive materials are forbidden to clean the equipment. Must ensure that the cleaner used will not pollute the environment.
10. This appliance can be used by children aged from 8 years and above and persons with reduced physical, sensory or mental capabilities or lack of experience and knowledge if they have been given supervision or instruction concerning use of the appliance in a safe way and understand the hazards involved. Children shall not play with the appliance.
11. Cleaning and user maintenance shall not be made by children without supervision.
12. If the supply cord is damaged, it must be replaced by the manufacturer, its service agent or a similarly qualified person in order to avoid a hazard.
13. Please make sure there is no hazard sources in your operating environment. e.g., do not litter the tools around. Always be careful to treat the packaging materials in order to avoid any possible danger, e.g. plastic bag may lead to choking hazard to children.
14. Keep the original package of the equipment if necessary in case of the future use in transportation.

## Waste disposal



This marking indicates that this product should not be disposed with other household wastes. To prevent possible harm to the environment or human health from uncontrolled waste disposal, recycle it responsibly to promote the sustainable reuse of material resources. To return your used device, please use the return and collection systems or contact the retailer where the product was purchased. They can take this product for environmental safe recycling.