

ASSEMBLY INSTRUCTIONS

Horizon L-Shaped Quadro A

Sizes: 1200x800, 1400x800, 1600x800, 1800x800 mm

www.jasonl.com.au

Need help!
Call us on
1300 527 665

jason.l
your office furniture mate

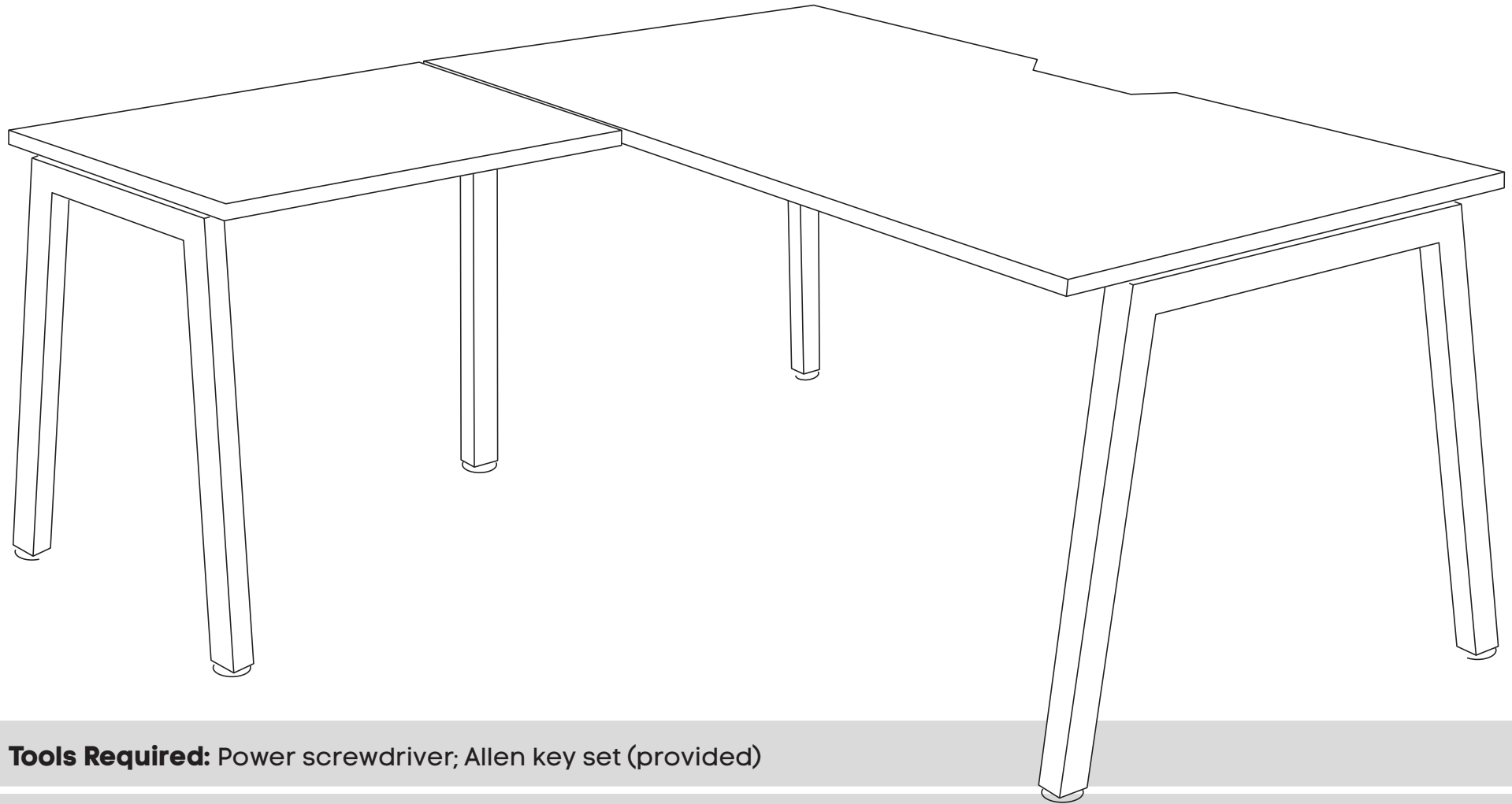

Tools Required: Power screwdriver; Allen key set (provided)

 2 persons required for installation

ASSEMBLY INSTRUCTIONS

Horizon L-Shaped Quadro A

www.jasonl.com.au

Need help!
Call us on
1300 527 665

jason.l
your office furniture mate



Sizes: 1200x800, 1400x800, 1600x800, 1800x800 mm

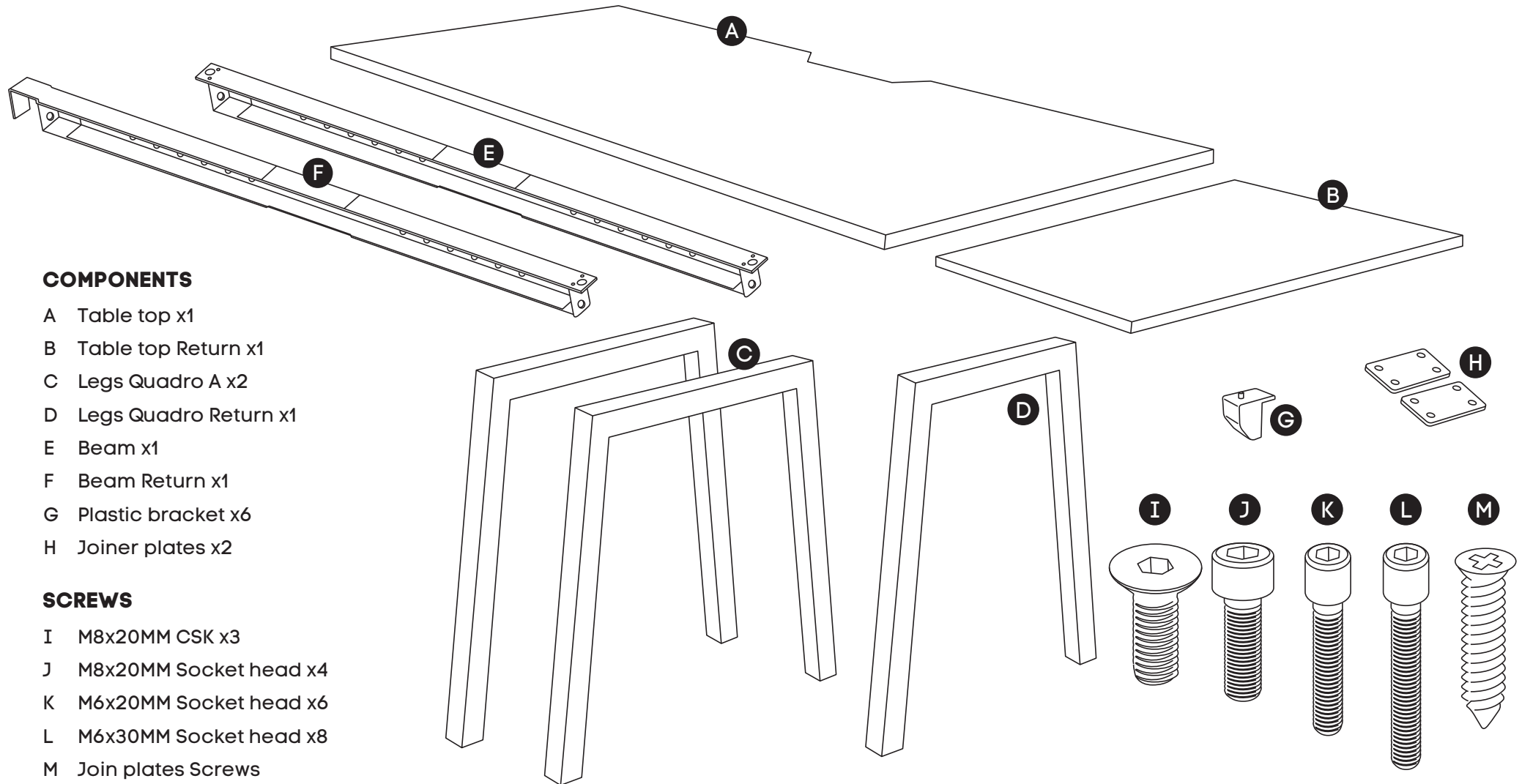

COMPONENTS

- A Table top x1
- B Table top Return x1
- C Legs Quadro A x2
- D Legs Quadro Return x1
- E Beam x1
- F Beam Return x1
- G Plastic bracket x6
- H Joiner plates x2

SCREWS

- I M8x20MM CSK x3
- J M8x20MM Socket head x4
- K M6x20MM Socket head x6
- L M6x30MM Socket head x8
- M Join plates Screws

N Allen key x2

ASSEMBLY INSTRUCTIONS

Horizon L-Shaped Quadro A

Sizes: 1200x800, 1400x800, 1600x800, 1800x800 mm

www.jasonl.com.au

Need help!
Call us on
1300 527 665

jason.l
your office furniture mate

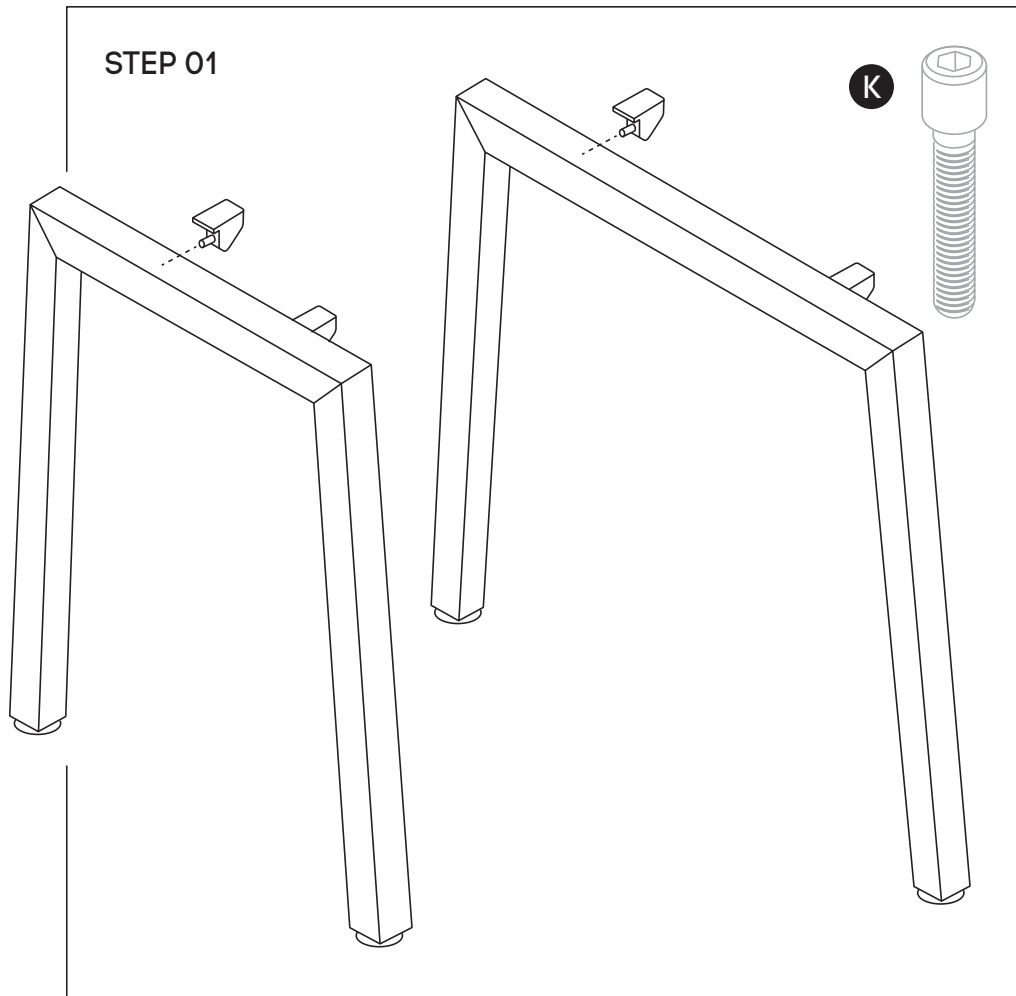

Using Allen Key provided, attach 2 plastic brackets (**G**) per legs (**C & D**) (as per picture above) using M6x20MM (**K**) Socket head screw.

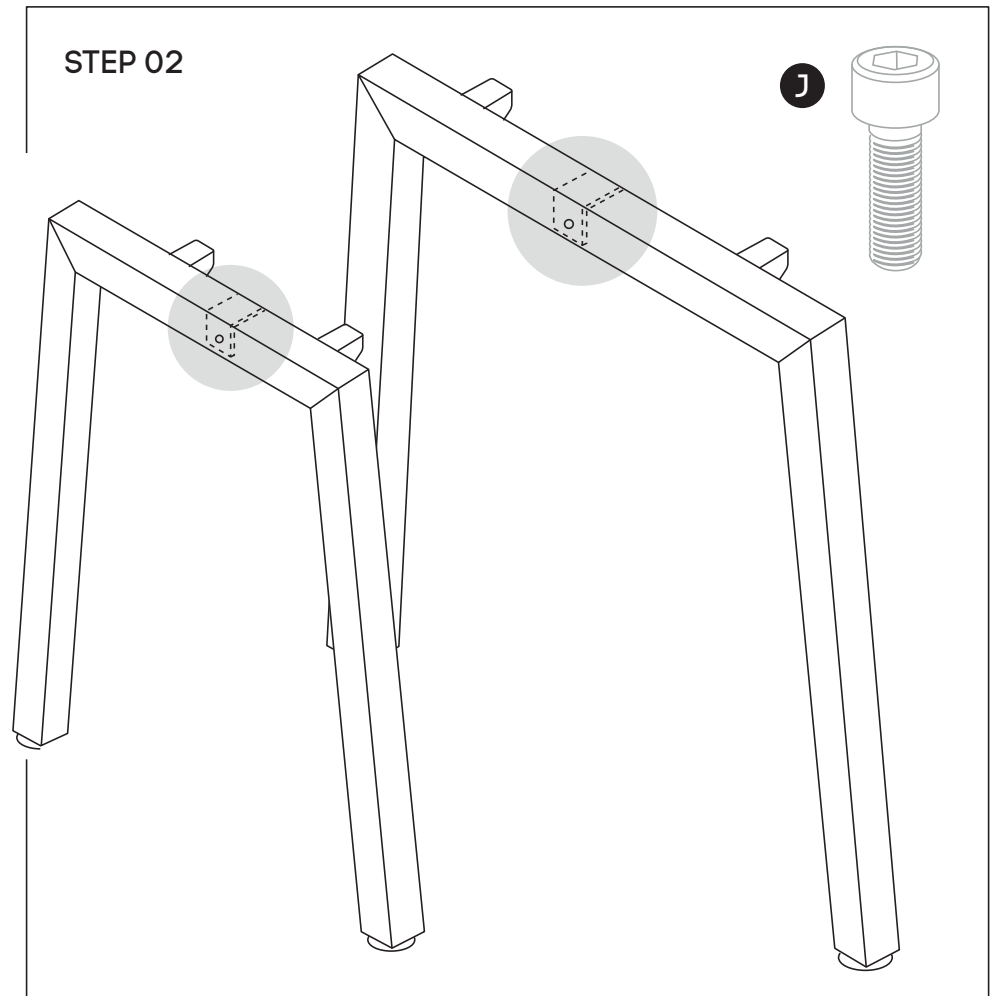

Using Allen Key provided, attach M8x20MM Socket head (**J**)-screw socket half way into leg for three legs (**C & D**)

ASSEMBLY INSTRUCTIONS

Horizon L-Shaped Quadro A

www.jasonl.com.au

Need help!
Call us on
1300 527 665

jason.l
your office furniture mate



Sizes: 1200x800, 1400x800, 1600x800, 1800x800 mm

STEP 03

Adjust extendable beam **(E)** to desired length using markers and secure beam at that length using screws provided

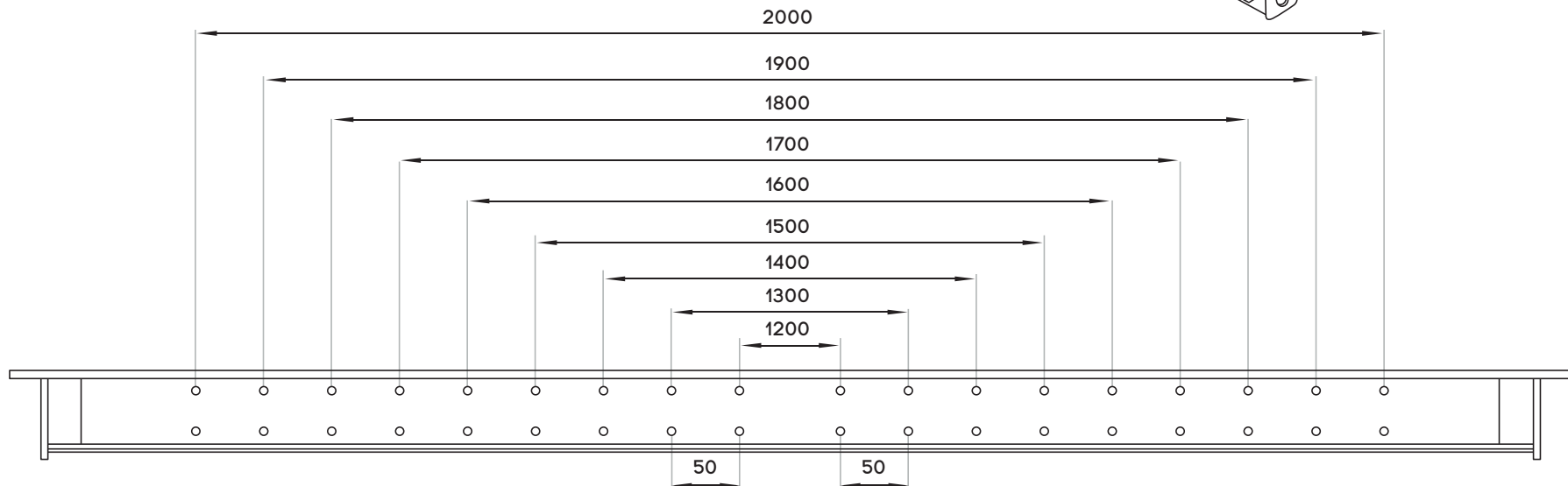
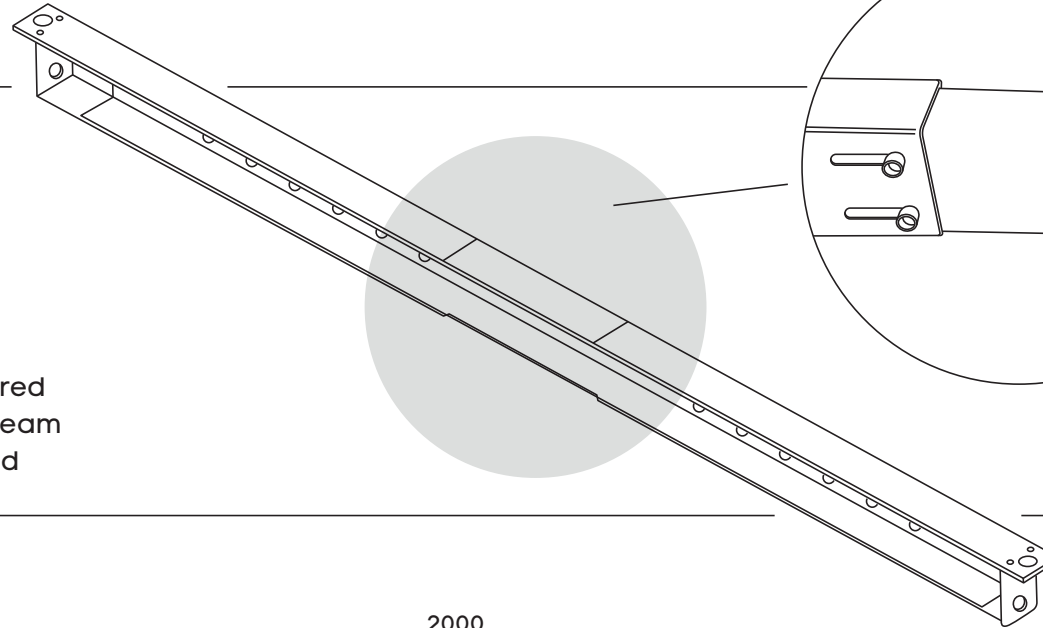

ASSEMBLY INSTRUCTIONS

Horizon L-Shaped Quadro A

Sizes: 1200x800, 1400x800, 1600x800, 1800x800 mm

www.jasonl.com.au

Need help!
Call us on
1300 527 665

jason.l
your office furniture mate

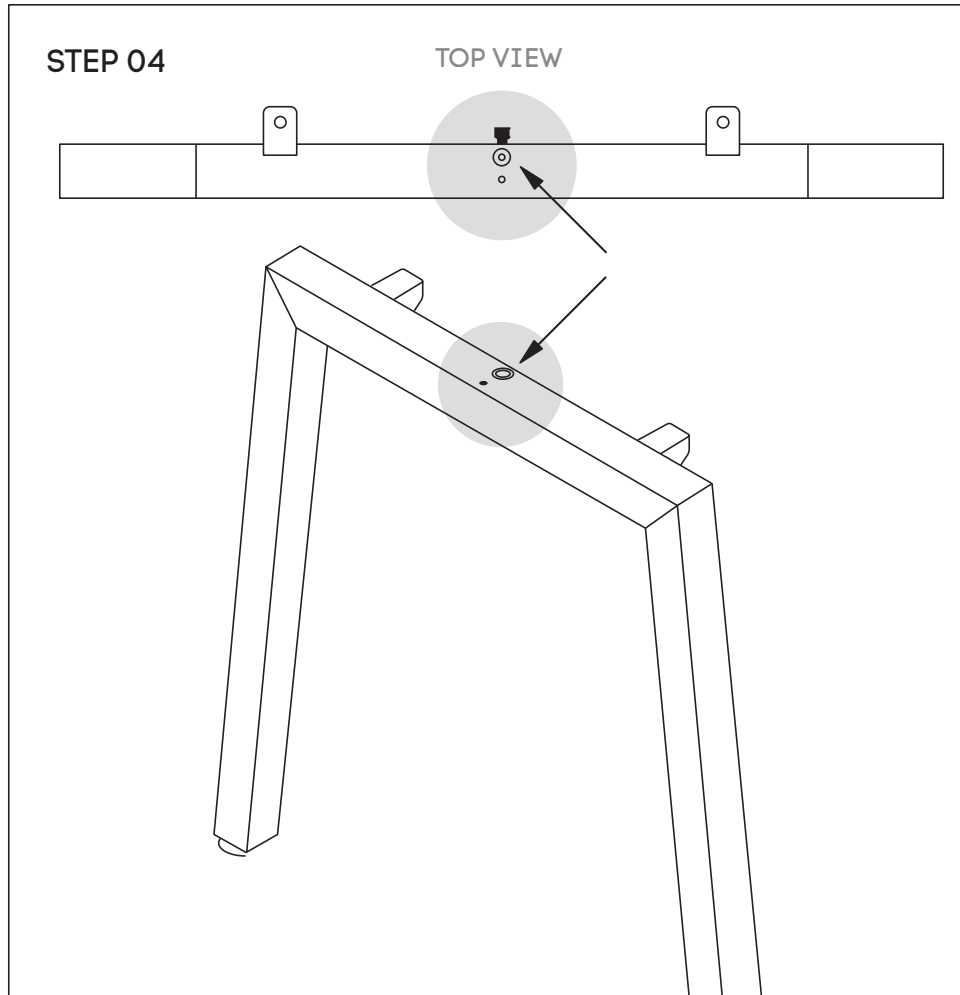
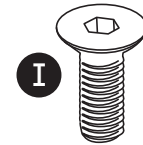

Attach beam **(E)** to legs **(C)** using nut insert in legs.
See point attached

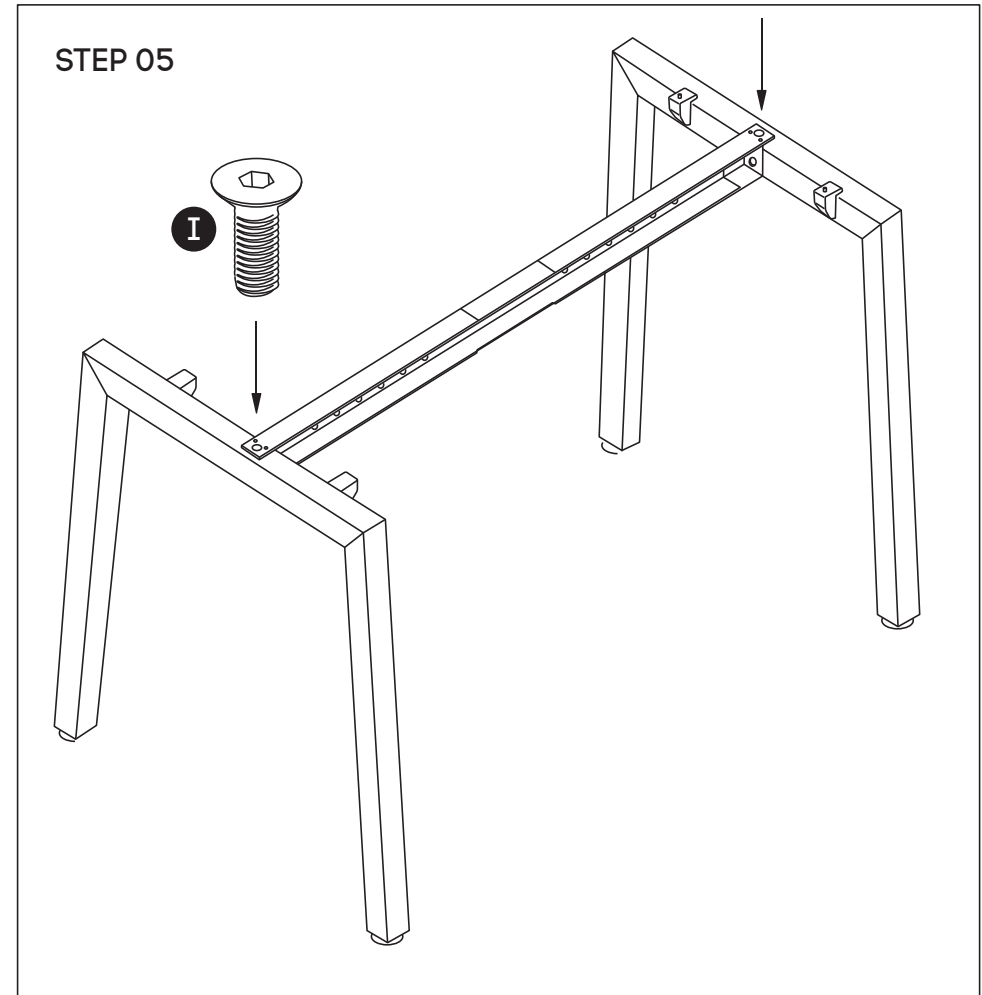

Frame looks like this. Using Allen Key, attach beam **(E)** with Socket **(I)**

ASSEMBLY INSTRUCTIONS

Horizon L-Shaped Quadro A

Sizes: 1200x800, 1400x800, 1600x800, 1800x800 mm

www.jasonl.com.au

Need help!

Call us on
1300 527 665

jason.l
your office furniture mate

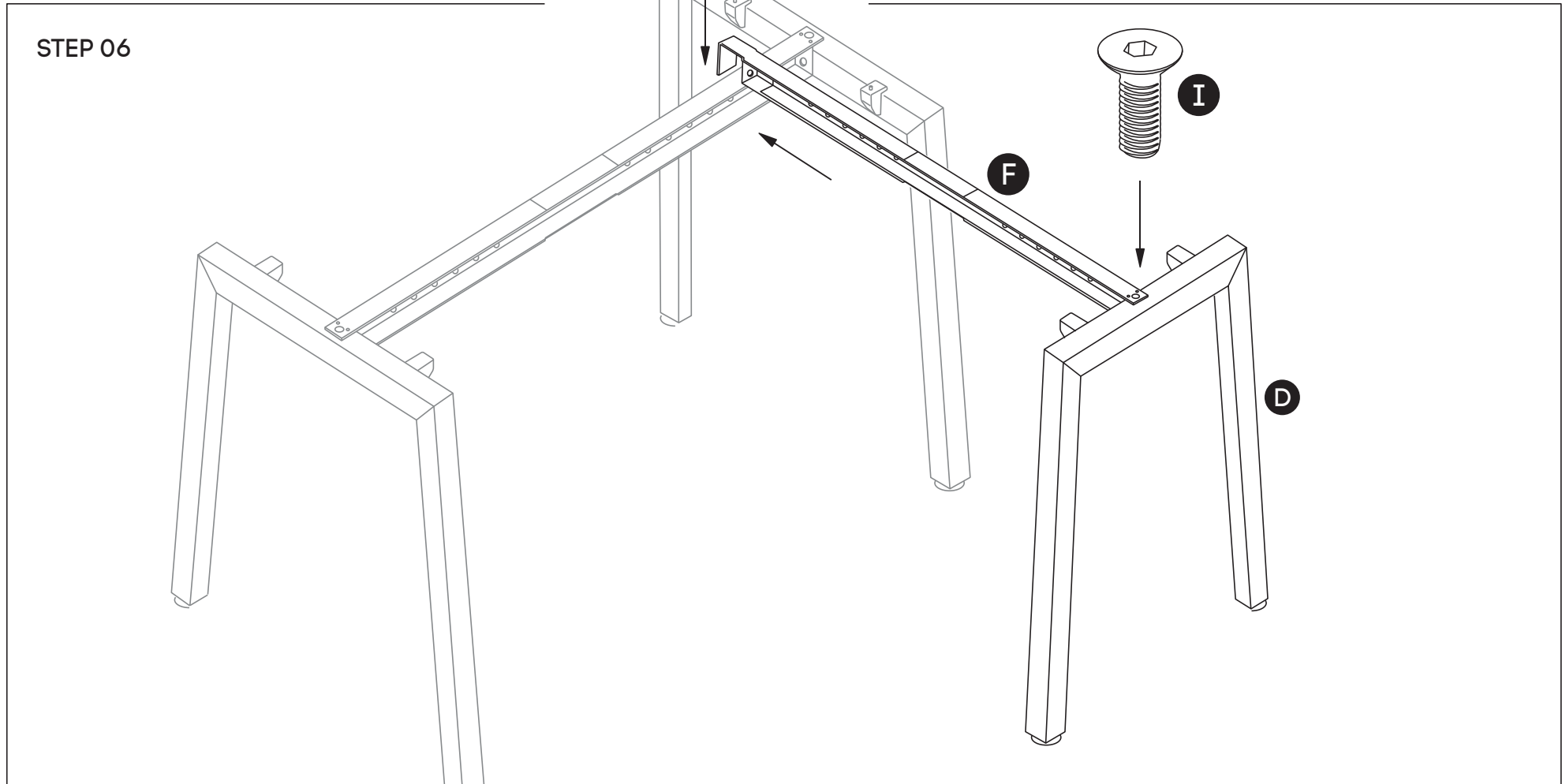

Now attach the return beam **(F)** to return leg **(D)** using nut insert in legs. See point attached.
Then, connect the hook of the return beam to the beam of the main structure.

ASSEMBLY INSTRUCTIONS

Horizon L-Shaped Quadro A

Sizes: 1200x800, 1400x800, 1600x800, 1800x800 mm

www.jasonl.com.au

Need help!

Call us on
1300 527 665

jason.l
your office furniture mate



STEP 07

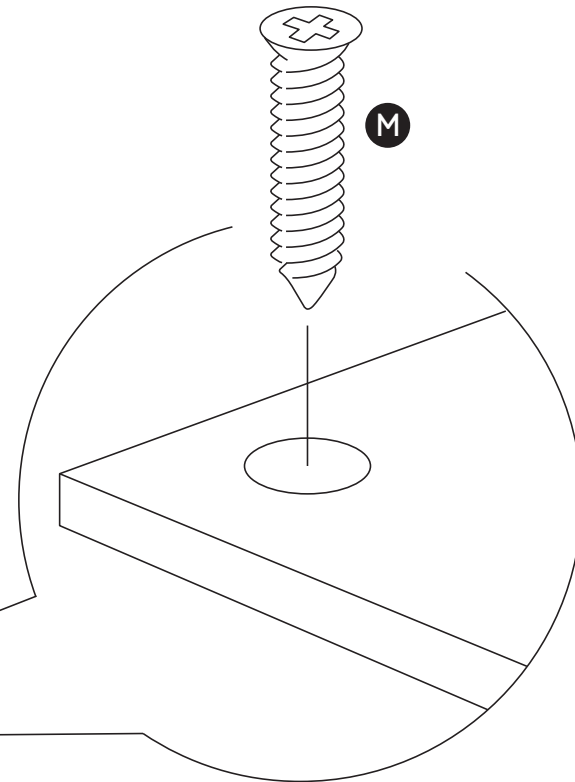
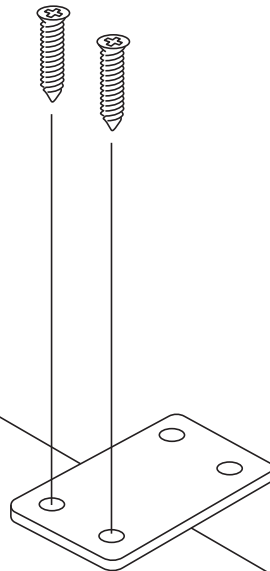
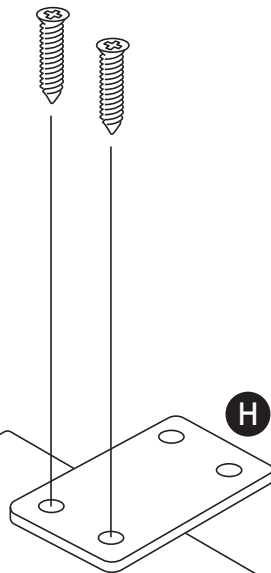

Attach Connector Plates **(H)** to Return Top **(B)** by tightening Screws **(M)**

ASSEMBLY INSTRUCTIONS

Horizon L-Shaped Quadro A

Sizes: 1200x800, 1400x800, 1600x800, 1800x800 mm

www.jasonl.com.au

Need help!

Call us on
1300 527 665

jason.l
your office furniture mate

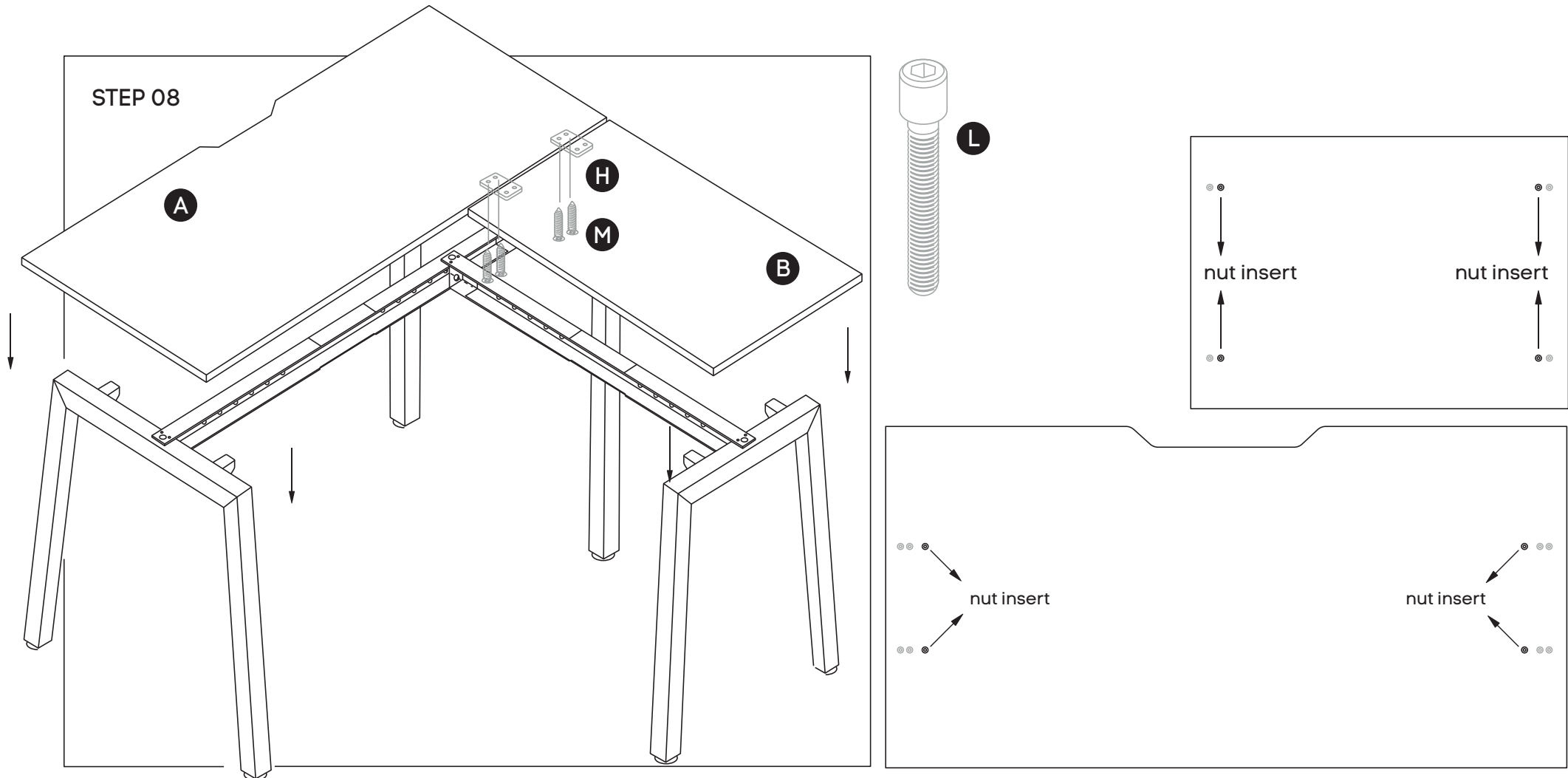

Place table top **(A)** ontop of frame - with cutout at the back of the desk. Using nut inserts in the desk, use M6x30mm socket **(L)** and attach desktop to the frame.

Using nut inserts in the desktop, use M6x30mm socket **(L)** and attach desktop **(B)** to the frame. Once desktop are attached and secure to the frame, use woods screws and secure joiner plates to the underside of desktop A.

TABLE TOP
BOTTOM VIEW

ASSEMBLY INSTRUCTIONS

Horizon L-Shaped Quadro A

Sizes: 1200x800, 1400x800, 1600x800, 1800x800 mm

www.jasonl.com.au

Need help!
Call us on
1300 527 665

jason.l
your office furniture mate

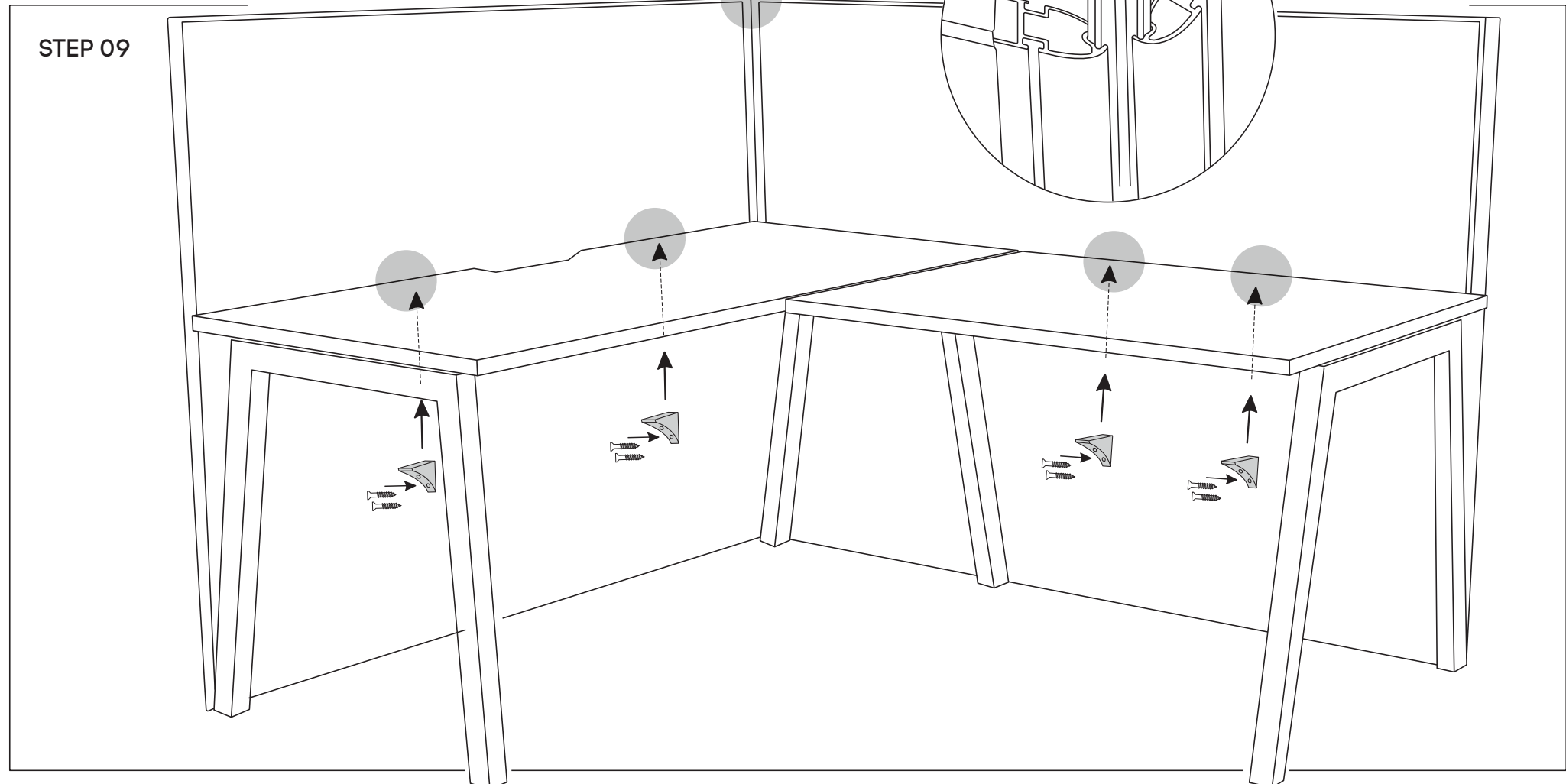

Using an Allen Key remove the top 2 caps from screens uprights. Bring two partition towards one another and slide the 90 degree connector rod - down between the two screen uprights. Under the desktop, use 4 I-shaped panel brackets to secure the screens to the desktops.