

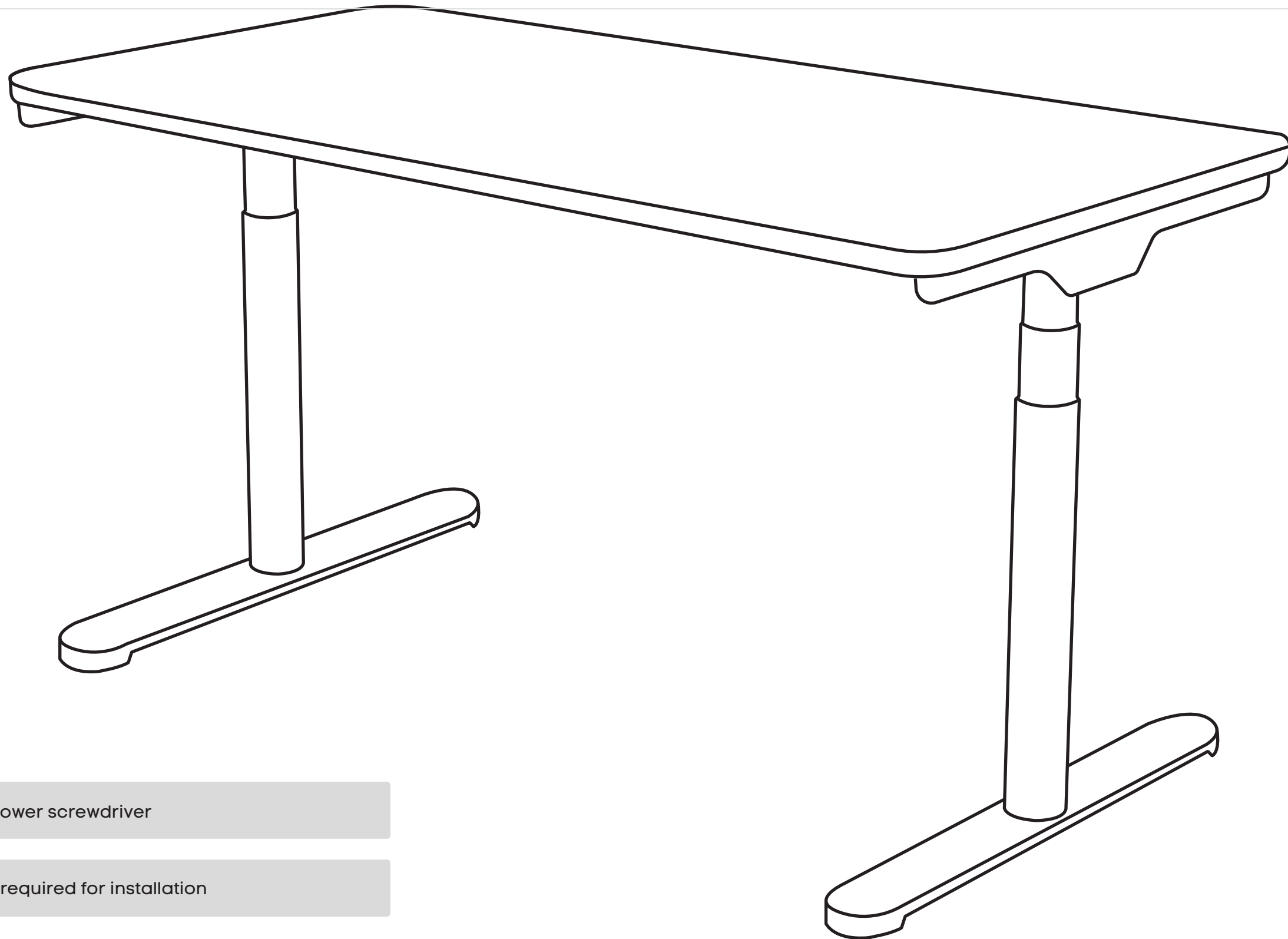

Flexi Premium Sit Stand Meeting Table

1800X1100



Tools Required: Power screwdriver

 2 persons required for installation

Need help!

Call us on **1300 527 665**

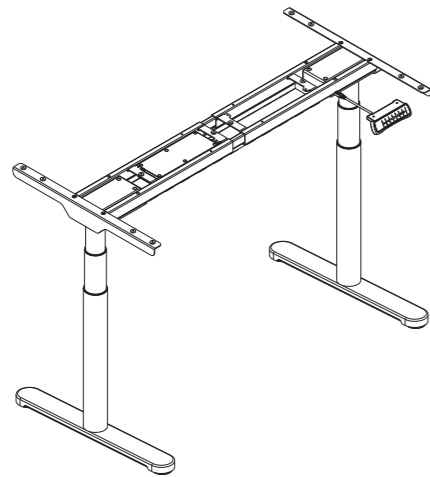

Technical data

Column Stage	3
Max. Weight Capacity	125KG
Height Range	600-1250mm
Width Range	1100-1900mm

Accessory list

Attention: The drawings below are for guidance only and they may differ slightly from the product and fittings received. Please contact our customer service department if you have any queries.

No.	Image	Spec	Qty
A		M6	4
B		M6	4
C		M6	8
D		M6	12
E		St4.2	16
F		Allen Key 4x4mm	1

Component list

No.	Part	Qty	No.	Part	Qty
①	Feet	2	②	Lifting Columns	2
③	Cable Management Tray	1	④	Supporting Beam (including control box)	1
⑤	Side Brackets	2	⑥	Handset (Option)	1
⑦	Power Cord	1	⑧	Handset Screws	2

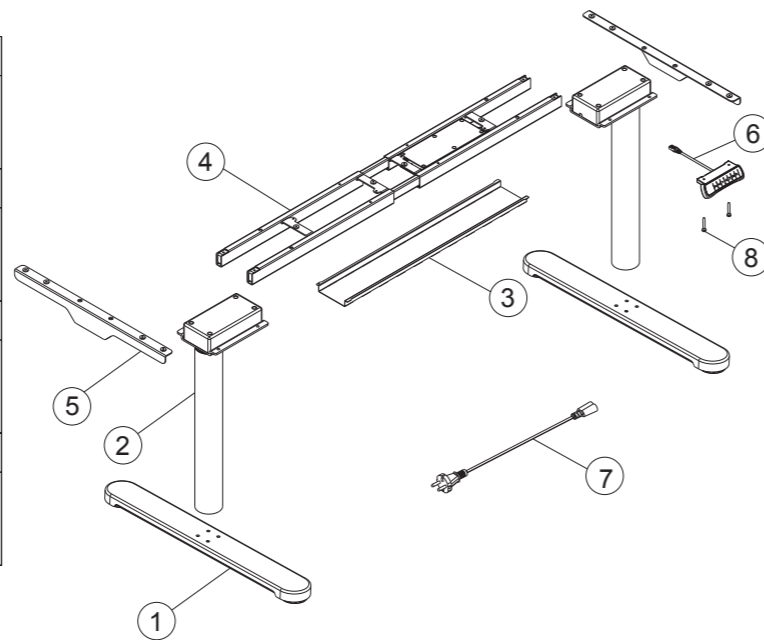

STEP 1

Connect side bracket to the supporting beam

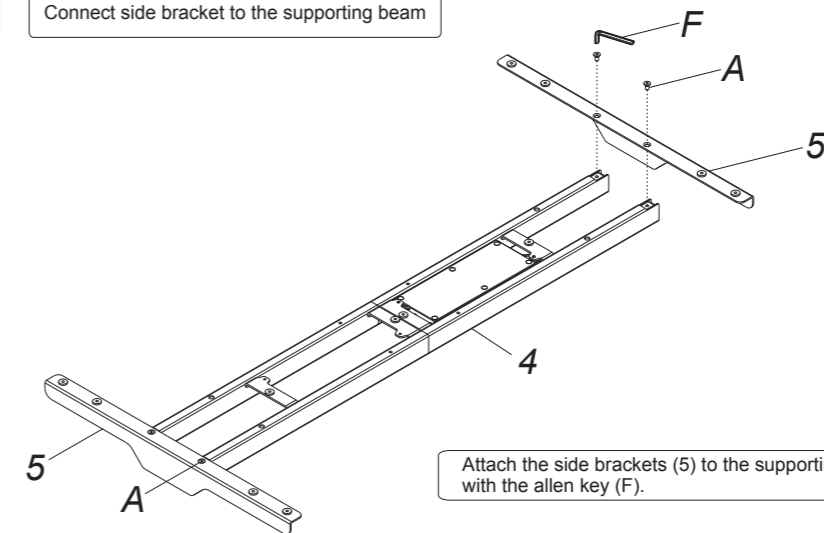

Attach the side brackets (5) to the supporting beam (4) using screws(A) with the allen key (F).

STEP 2

Install the lifting columns

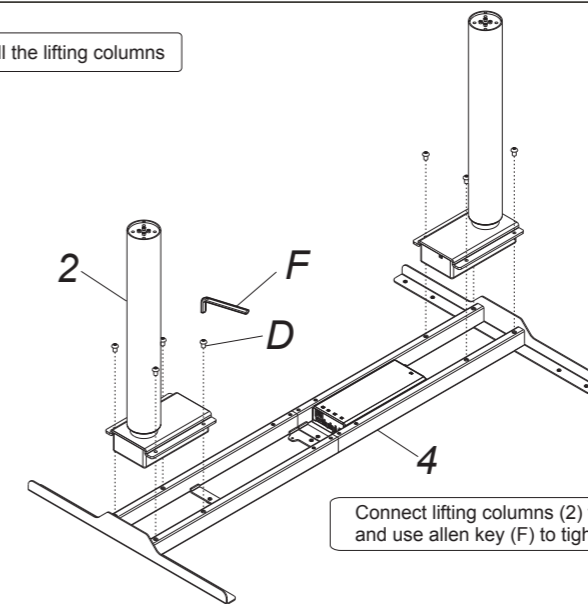

Connect lifting columns (2) to the supporting beam (4) with screws (D) and use allen key (F) to tighten.

STEP 3

Install the feet

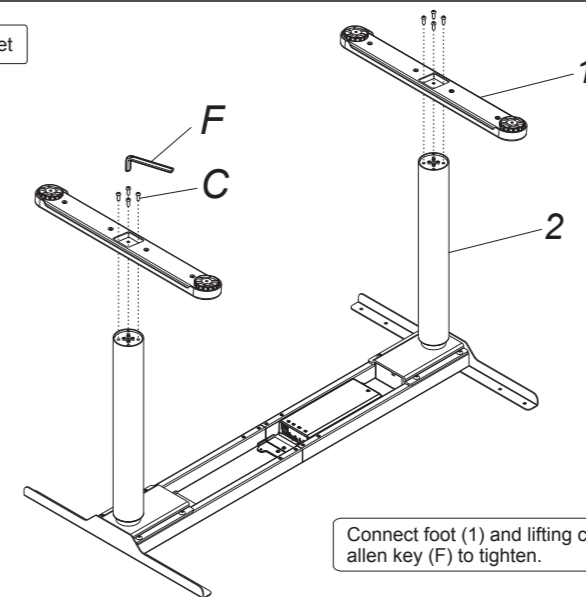

Connect foot (1) and lifting column (2) with screws (C) and use allen key (F) to tighten.

Need help!

Call us on **1300 527 665**

www.jasonl.com.au

2 of 3

STEP 4

Install tabletop and handset

1 Attention: When the extension of supporting beam is larger than 1720mm, the installation method is as follows: Method 2 in Step 6.

E x12

F 4x4

The extension distance of the supporting beam can be adjusted according to the actual use.

Fix the tabletop on the frame with screws (E) and use screws (8) to fix handset (6).

2

Loosen

Adjust

Tighten

Method 2

When the supporting beam (3) stretches over 1720mm, the cable management tray needs to be mounted on the middle of the supporting beam.

Install the cable management tray (3) as Method 1, Step 6.

B x4

D x4

F 4x4

STEP 1: Tighten the screws (B). And screw the screws (D) incompletely.

The supporting beam should not exceed this hole.

STEP 5

Connect all cables to the control box

7

Port for power plug

Port for handset

Ports for lifting columns

6

Common fault treatment

The following tips will help you detected and eliminate the common fault and error. If the fault you met is not listed below, please contact with your supplier. Only the manufacturer and professionals are capable for investigating and correcting those fault and error.

Fault phenomenon	Method
The desktop could not function	Check if all the cables well connected;
Rising in a low speed	Check if overloaded, max loading: 125kg;
The desk moving downwards without any operation	
Automatically Self-Reset	Reset;
Go down but not go up or go up but not go down	
The upper and downward height is not enough	
The desk could not lifted	Restart after suspend for 18mins while connecting with power.
Overwork (Duty cycle: Max 2min on/18min OFF)	

Attention

- Power supply: AC100V-240V, 50/60Hz
- Service Environment: 0-40°C
- Unplug the power plug before cleaning, wipe the dust on surface with slight wet dishcloth when cleaning, be careful not to let the drops into the internal parts, not loose the connector.
- The electric box contains electronic components, metals, plastics, wires etc., so dispose of it in accordance with each country's environmental legislation, not the general household waste.
- Check carefully to ensure correct and complete assembly before using.
- Be familiar with all functions and program settings of the product before first use.
- Children are forbidden to play on the product because of unforeseen action when playing, so any dangerous consequences caused by this improper action will not be on manufacturers.
- Slight noise caused by the V-ribbed belt or brake system due to structure will not have any effect on the use of the equipment.
- Corrosive or abrasive materials are forbidden to clean the equipment. Must ensure that the cleaner used will not pollute the environment.
- This appliance can be used by children aged from 8 years and above and persons with reduced physical, sensory or mental capabilities or lack of experience and knowledge if they have been given supervision or instruction concerning use of the appliance in a safe way and understand the hazards involved. Children shall not play with the appliance.
- Cleaning and user maintenance shall not be made by children without supervision.
- If the supply cord is damaged, it must be replaced by the manufacturer, its service agent or a similarly qualified person in order to avoid a hazard.
- Please make sure there is no hazard sources in your operating environment, e.g., do not litter the tools around. Always be careful to treat the packaging materials in order to avoid any possible danger, e.g. plastic bag may lead to choking hazard to children.
- Keep the original package of the equipment if necessary in case of the future use in transportation.

STEP 6

Install the cable management tray

B x4

F 4x4

Method 1

STEP 1: Tighten the screws incompletely

Firstly, rotate the screws (B) incompletely into the supporting beam (4) with allen key (F). Next, slide one side of the cable management tray (3) into the screws (B), then the other side. Finally, tighten the screws (B) with allen key (F).

STEP 2: Buckle the tray

1 Buckle from one side

2 Buckle the other side

3 Tighten

Waste disposal

This marking indicates that this product should not be disposed with other household wastes. To prevent possible harm to the environment or human health from uncontrolled waste disposal, recycle it responsibly to promote the sustainable reuse of material resources. To return your used device, please use the return and collection systems or contact the retailer where the product was purchased. They can take this product for environmental safe recycling.

Need help! Call us on **1300 527 665**