

ASSEMBLY INSTRUCTIONS

# Elements 6 Person Workstation

Size: 1600mm

[www.jasonl.com.au](http://www.jasonl.com.au)

**Need help!**

Call us on  
**1300 527 665**

**jason.l**  
your office furniture mate

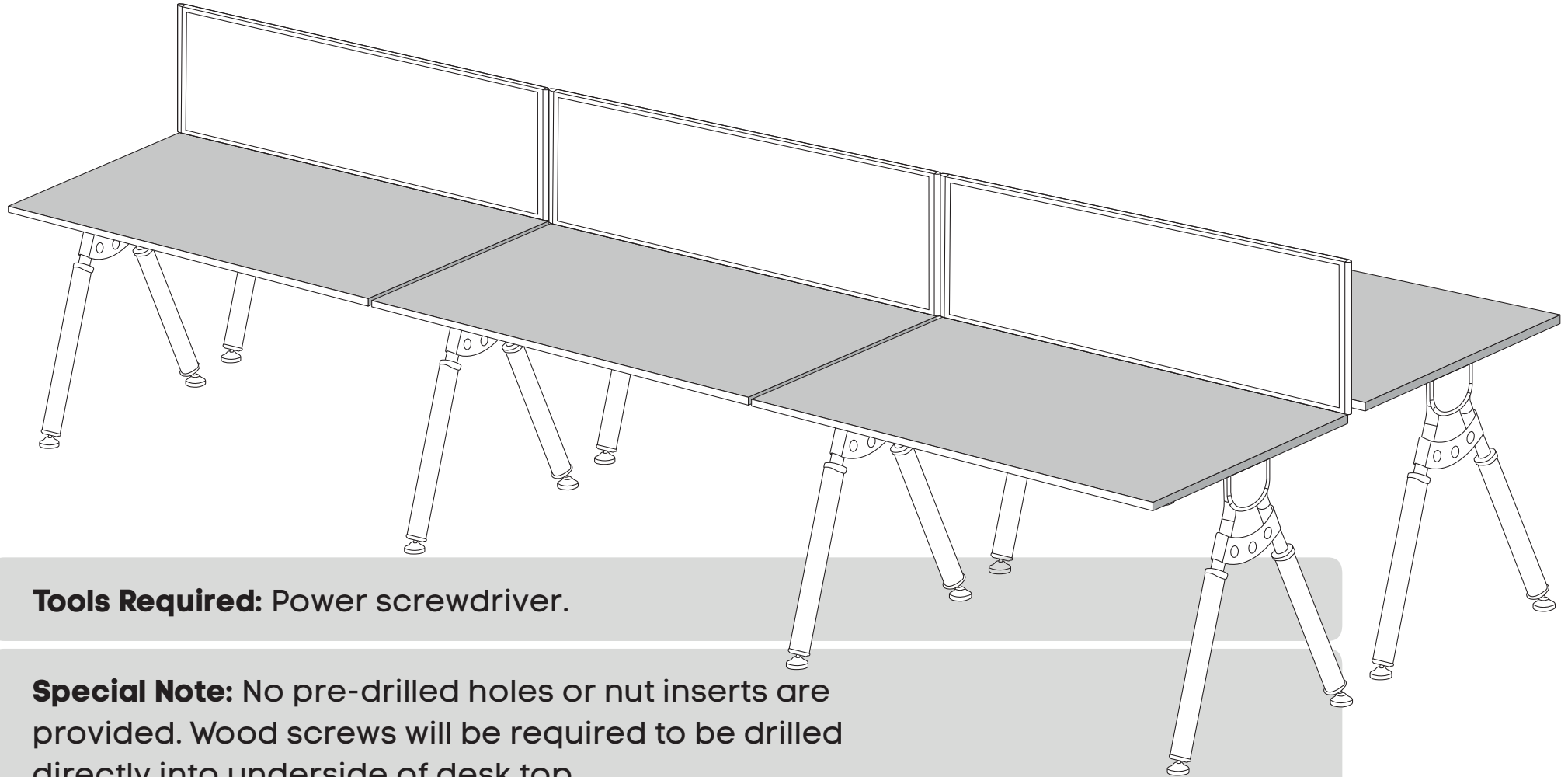

**Tools Required:** Power screwdriver.

**Special Note:** No pre-drilled holes or nut inserts are provided. Wood screws will be required to be drilled directly into underside of desk top.

 2 persons required for installation

## ASSEMBLY INSTRUCTIONS

# Elements 6 Person Workstation

Size: 1600mm

[www.jasonl.com.au](http://www.jasonl.com.au)

**Need help!**

Call us on  
**1300 527 665**

**jason.l**  
your office furniture mate

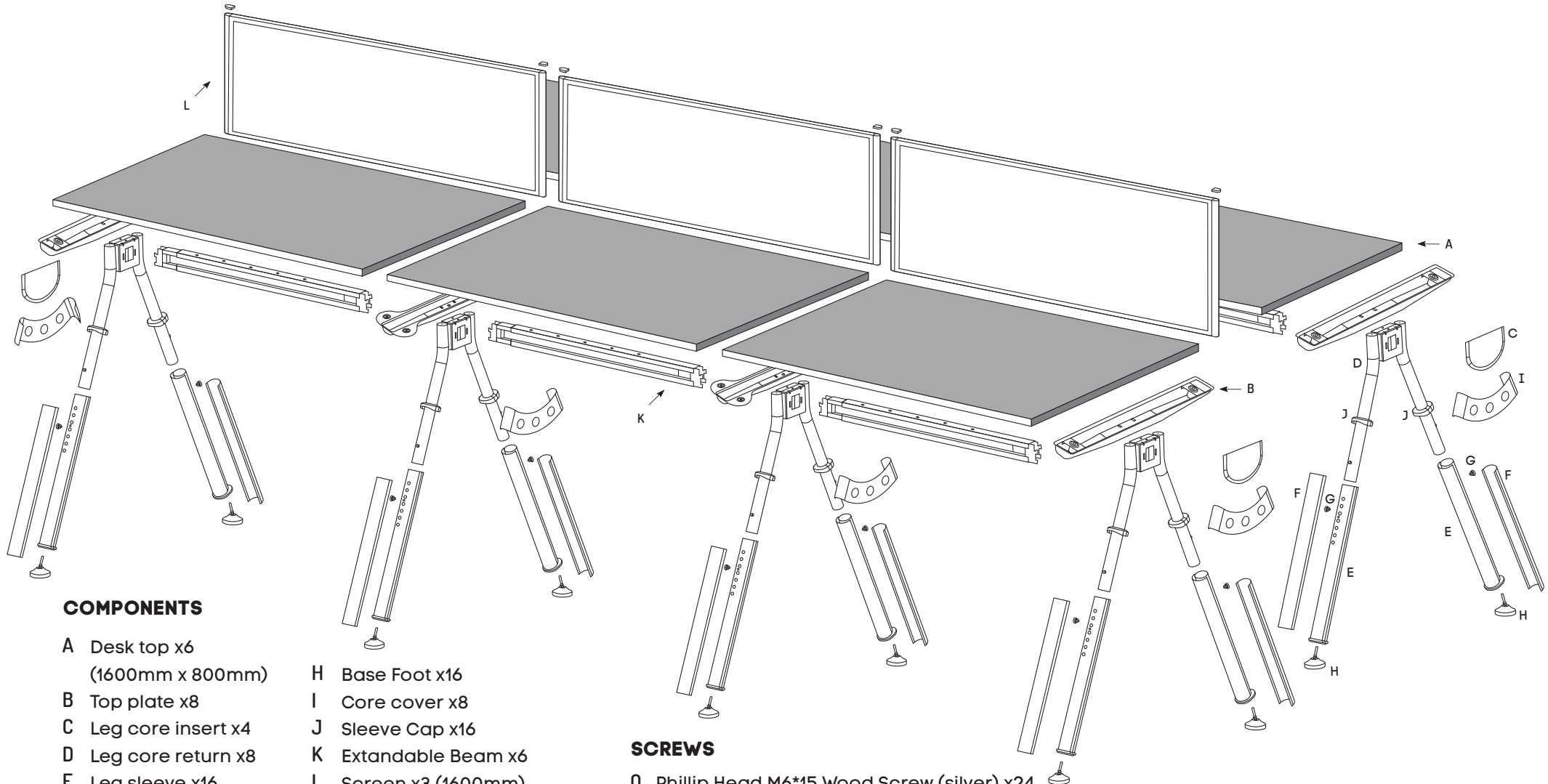

### COMPONENTS

- |                                   |                               |
|-----------------------------------|-------------------------------|
| A Desk top x6<br>(1600mm x 800mm) | H Base Foot x16               |
| B Top plate x8                    | I Core cover x8               |
| C Leg core insert x4              | J Sleeve Cap x16              |
| D Leg core return x8              | K Extendable Beam x6          |
| E Leg sleeve x16                  | L Screen x3 (1600mm)          |
| F Sleeve cover x16                | M Rod Brackets for screens x6 |
| G Fold Screen x16                 | N 2 way screen connector x2   |

### SCREWS

- |                                              |
|----------------------------------------------|
| O Phillip Head M6*15 Wood Screw (silver) x24 |
| P Phillip Flat Head M6*20 Screw (gold) x32   |
| Q H6x30 x24                                  |

## ASSEMBLY INSTRUCTIONS

# Elements 6 Person Workstation

Size: 1600mm

[www.jasonl.com.au](http://www.jasonl.com.au)

**Need help!**

Call us on  
**1300 527 665**

**jason.l**  
your office furniture mate



01

- Unwrap all leg components.
- Remove sleeve cap (J) and sleeve cover (F) from all leg sleeves.
- Insert base foot (H) into leg sleeve (E) by rotating base foot (H) clockwise.
- Insert sleeve cap (J) onto leg core (D) for all legs.
- Insert leg sleeve (E) onto leg core (D) for all legs. TIP: Keep height adjustment holes pointing outwards.
- Place leg core insert (C) onto leg core (D) for all legs.
- Place core cover (I) onto leg core (D) for all legs.
- Place sleeve cover (F) over leg sleeve (E) for all legs.

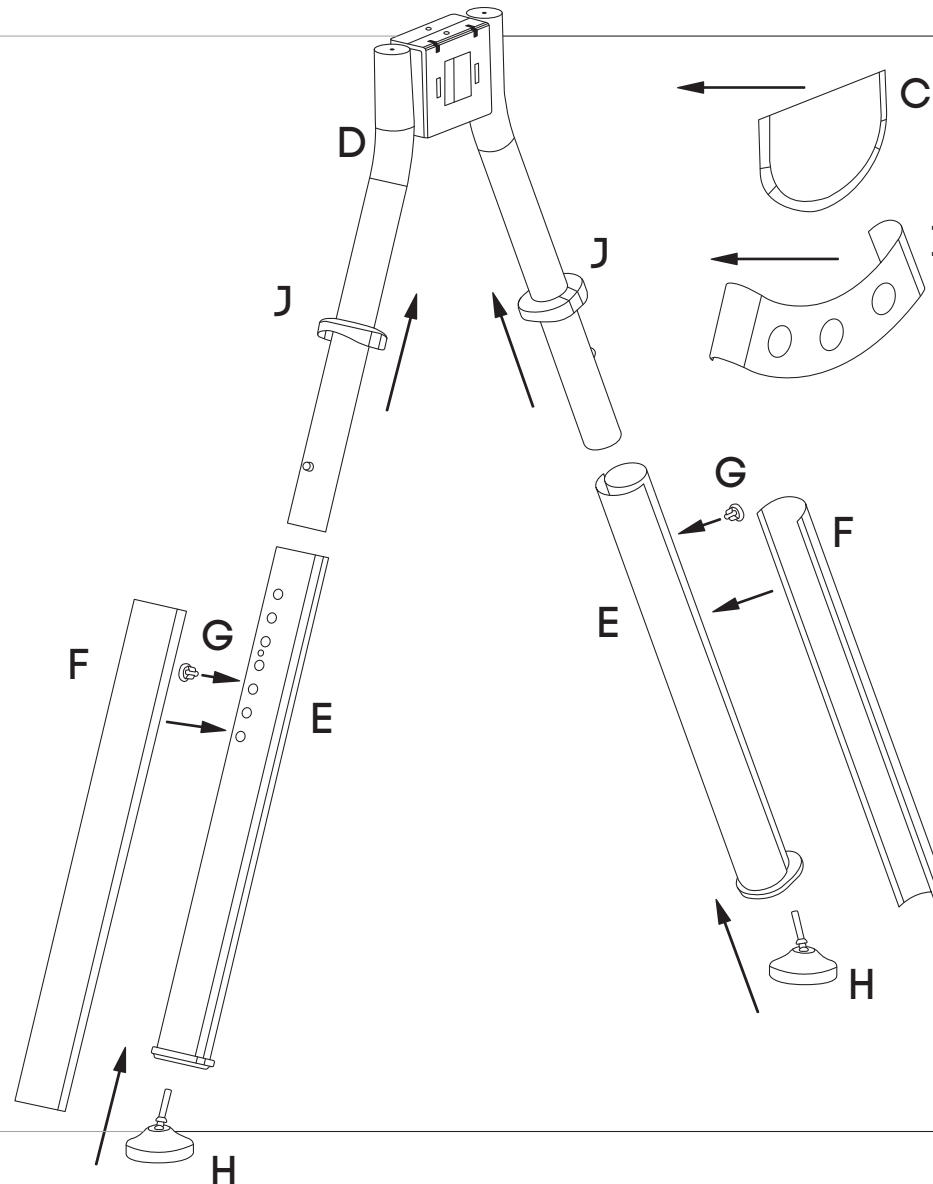

ASSEMBLY INSTRUCTIONS

# Elements 6 Person Workstation

Size: 1600mm

[www.jasonl.com.au](http://www.jasonl.com.au)

**Need help!**

Call us on  
**1300 527 665**

**jason.l**  
your office furniture mate

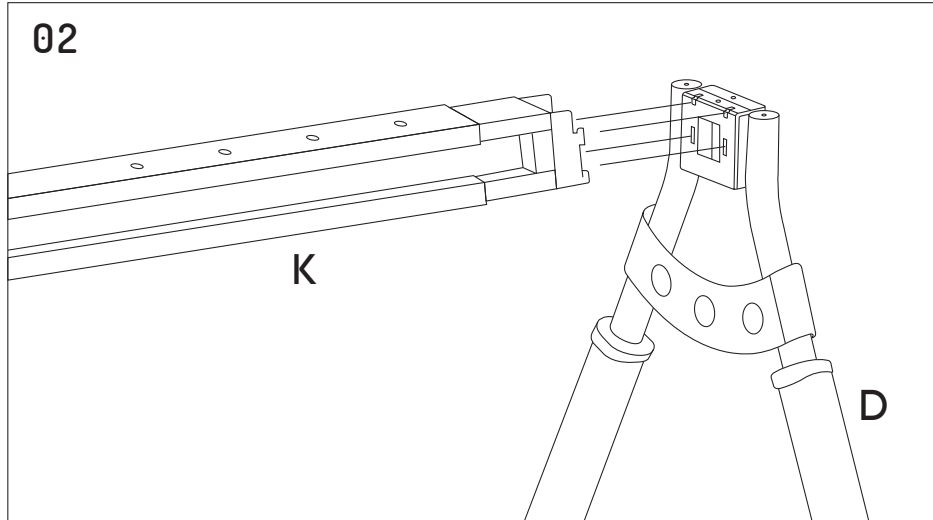

Connect extendable Beams (K) to Legs Core (D)

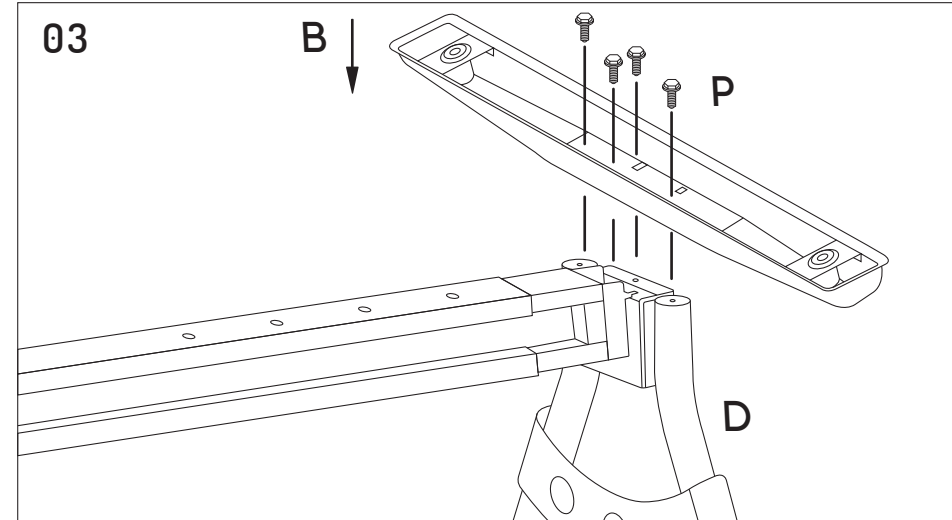

Tighten Top Plates (B) to outer legs core (D) by tightening Screw (P).

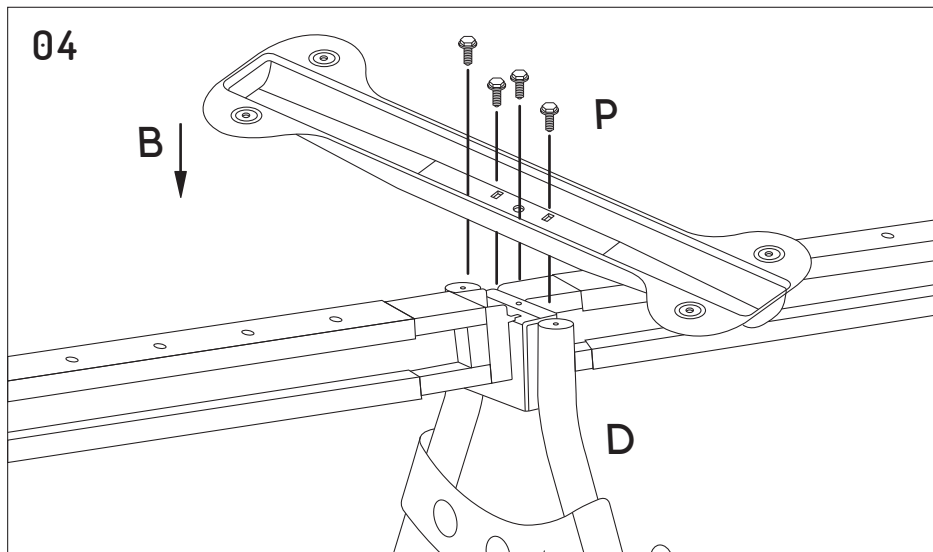

Tighten Top Plates (B) to middle legs core (D) by tightening Screw (P).

ASSEMBLY INSTRUCTIONS

# Elements 6 Person Workstation

Size: 1600mm

[www.jasonl.com.au](http://www.jasonl.com.au)

**Need help!**

Call us on  
**1300 527 665**

**jason.l**  
your office furniture mate

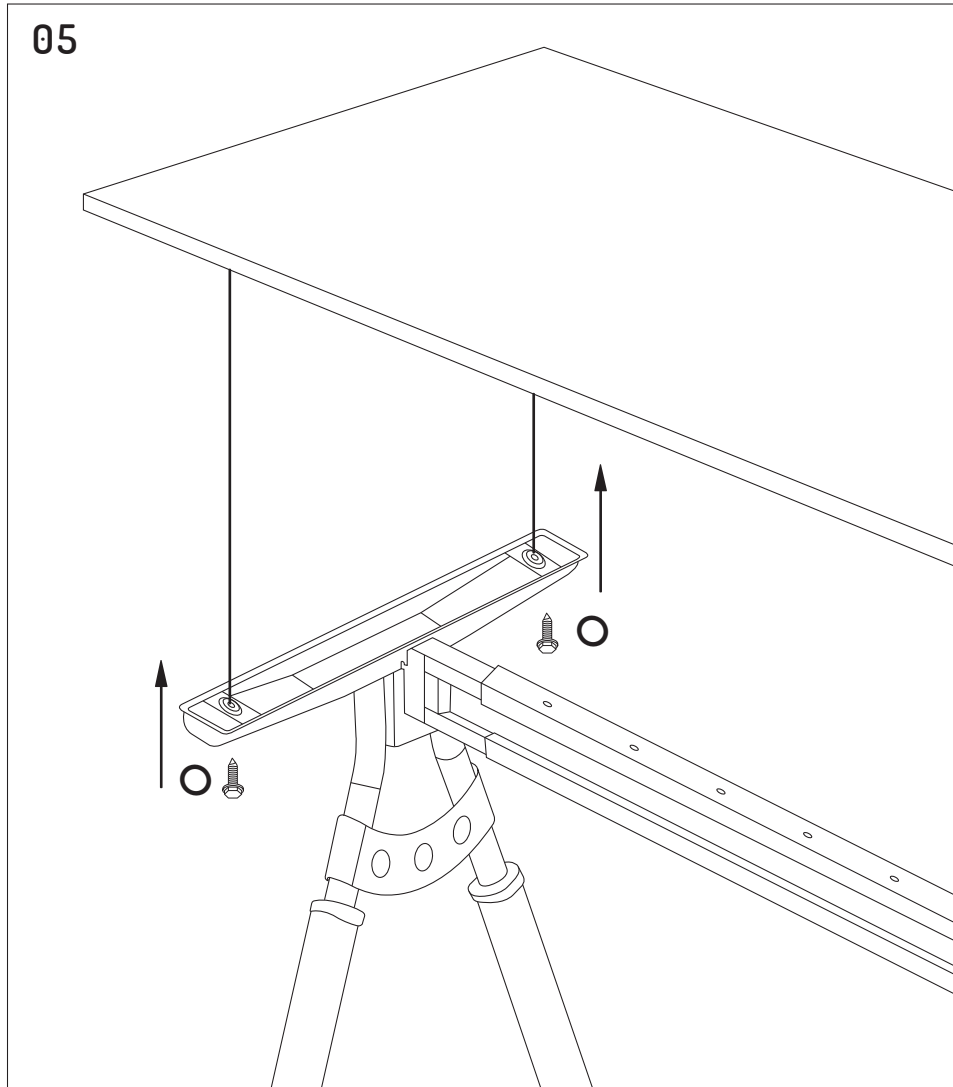

Attach outsider legs + beam to Desk Tops by tightening Scews (O).

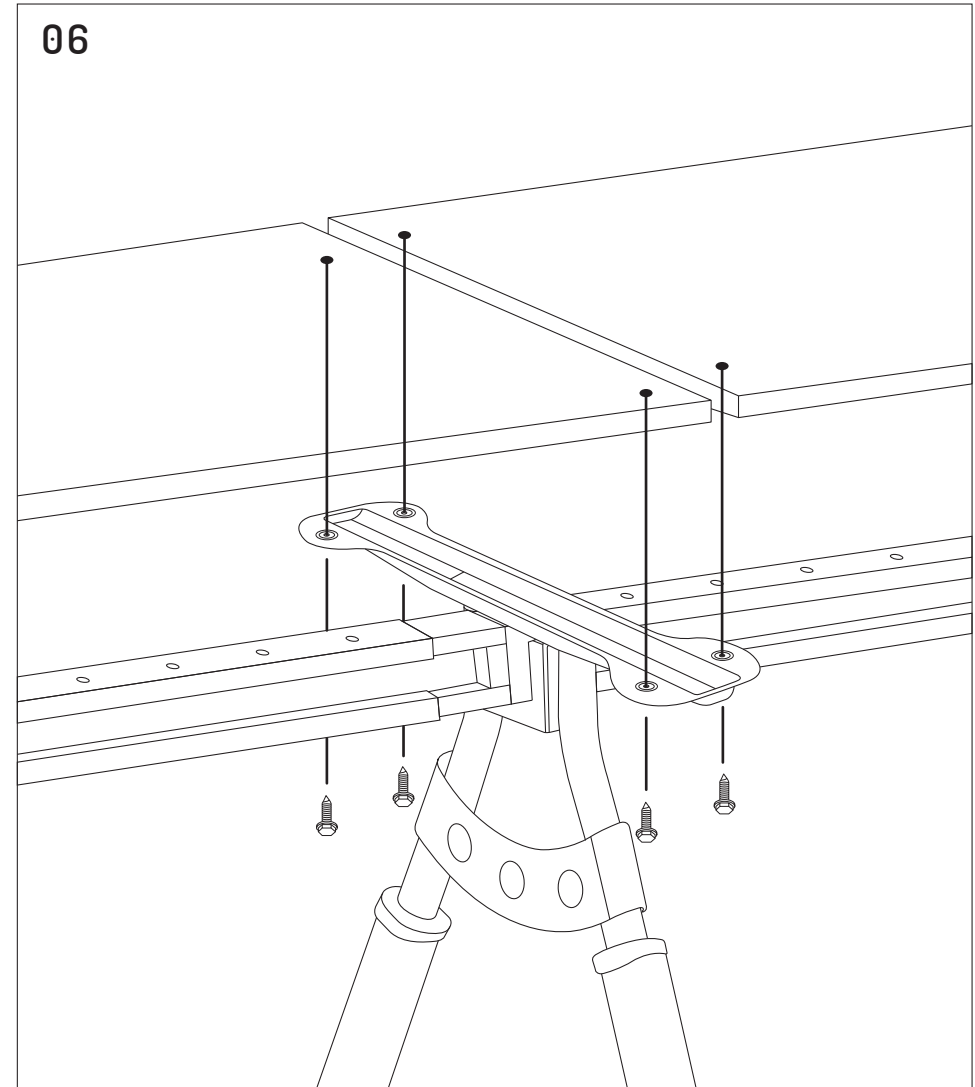

Attach middle leg to Desk Tops by tightening Scews (O).

ASSEMBLY INSTRUCTIONS

# Elements 6 Person Workstation

Size: 1600mm

[www.jasonl.com.au](http://www.jasonl.com.au)

**Need help!**

Call us on  
**1300 527 665**

**jason.l**  
your office furniture mate

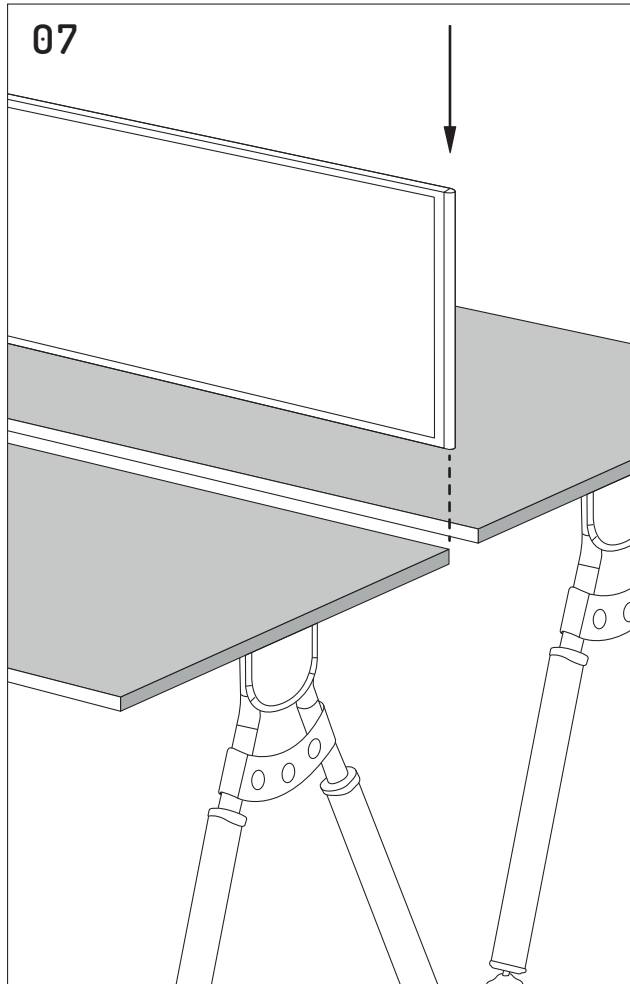

Place screens (L) in the gap, aligned with desk tops (A).

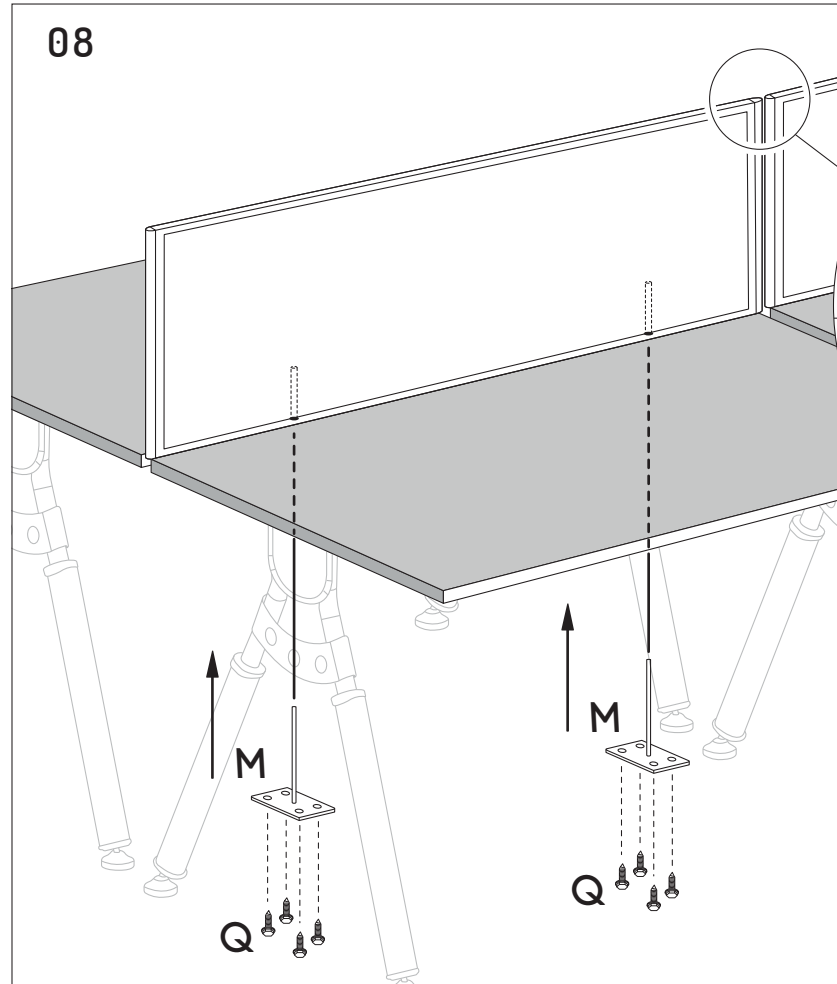

Place 10mm Rod Brackets (M) into designated screen holes.  
Drill desk tops (A) with H6x30 screws (Q) to assemble the screens.

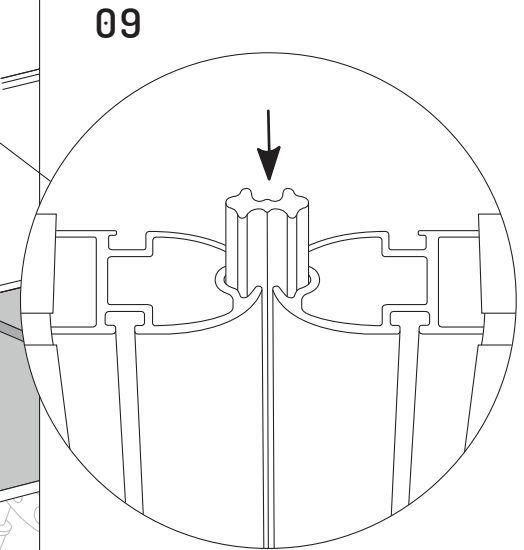

Using an Allen key remove top 2 caps from all screens (L) uprights. Bring two partition towards one another and slide the 2 way connector rod (N) - down between the two screen uprights.